

Electricity and Magnetism

University Physics II-Part 1: Notes and exercises

Daniel Gebreselasie



Download free books at

DANIEL GEBRESELASIE

ELECTRICITY AND MAGNETISM

UNIVERSITY PHYSICS II-PART 1:
NOTES AND EXERCISES

Electricity and Magnetism: University Physics II-Part 1: Notes and exercises

1st edition

© 2015 Daniel Gebreselasie & bookboon.com

ISBN 978-87-403-1127-3

CONTENTS

1	Electric Forces and Fields	6
2	Gauss's Law	24
3	Electric Potential	48
4	Capacitance and Dielectric	74
5	Current and Resistance	97
6	Direct Current Circuits	112
7	Magnetic Fields	139

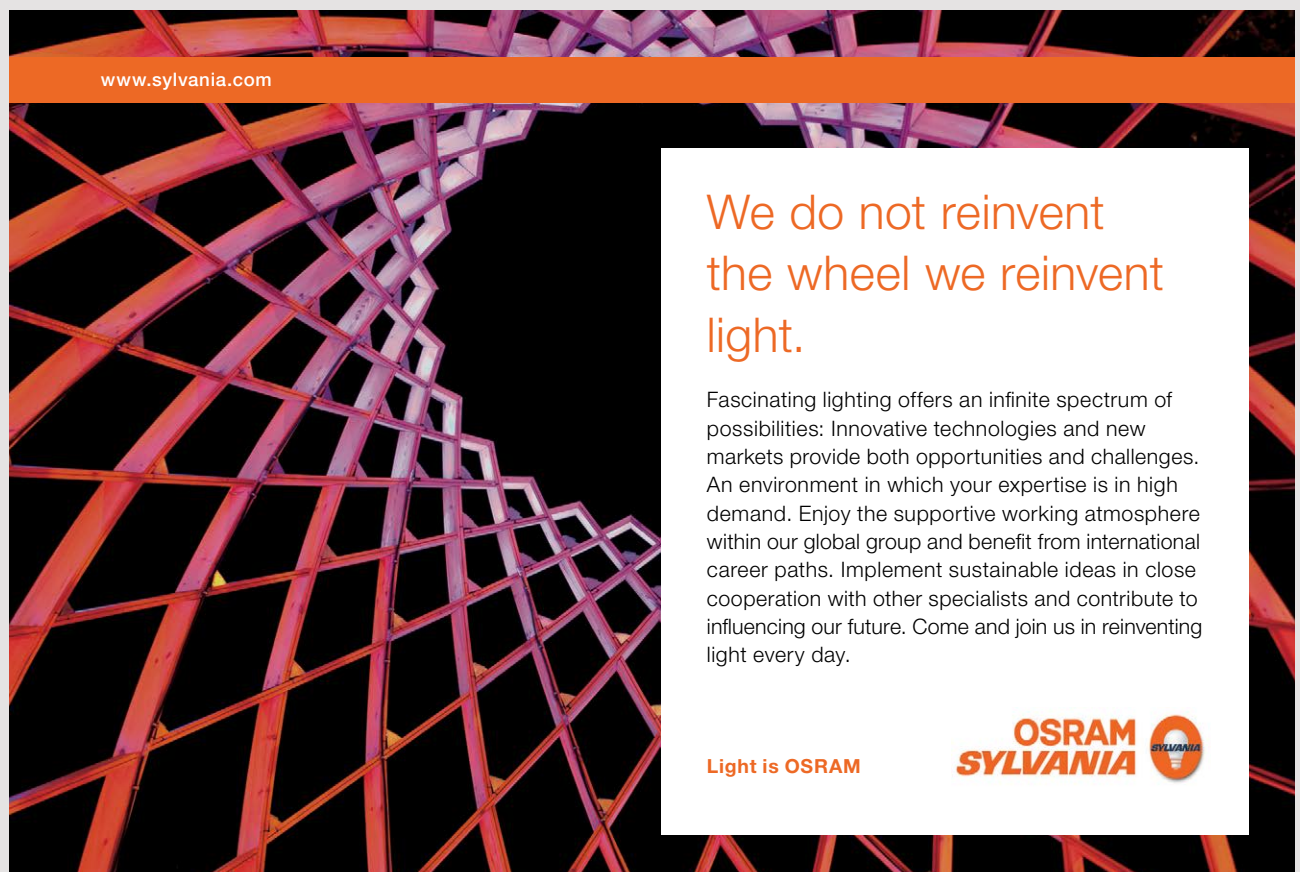

www.sylvania.com

We do not reinvent
the wheel we reinvent
light.

Fascinating lighting offers an infinite spectrum of possibilities: Innovative technologies and new markets provide both opportunities and challenges. An environment in which your expertise is in high demand. Enjoy the supportive working atmosphere within our global group and benefit from international career paths. Implement sustainable ideas in close cooperation with other specialists and contribute to influencing our future. Come and join us in reinventing light every day.

Light is OSRAM

OSRAM SYLVANIA 

8	Sources of the Magnetic Field	163
9	Faraday's Law	200
10	Inductance	219
11	Alternating Current Circuits	245
	Answers to Practice Quizzes	264

1 ELECTRIC FORCES AND FIELDS

Your goal for this chapter is to understand the nature of electric forces and fields, and the superposition of electric forces and fields.

Electric Force

Experiment shows that when rubber and fur are rubbed together, they develop the property of attracting each other. This kind of force that arises after objects are rubbed together is called *electrical force*. The change that occurred during the rubbing process that is responsible for this force is called *charge*. When another pair of rubber are rubbed together, the two rubbers (or the two furs) repel each other. This shows that there are two kinds of charges and that opposite charges attract and similar charges repel. Mathematically, these two different kind of charges are identified as positive and negative. The SI unit of measurement for charge is the Coulomb, abbreviated as C.

Objects usually contain equal amounts of positive and negative charge; electrical forces between objects arise when those objects have net negative or positive charges.

According to the Rutherford model of the atom, an atom consists of a nucleus with protons and neutrons with electrons revolving around. A neutron have no charge. An electron has a negative charge of $-1.60 \times 10^{-19} \text{C}$. A proton has a positive charge numerically equal to that of the electron.

According to the current understanding of charges, when rubber and fur are rubbed together, electrons are transferred from one to the other. The one that lost electrons becomes positively charged because it is losing negatively charged electrons, and the one that gained electrons becomes negatively charged because it is gaining negative charges.

Charges are measured by a device called electroscope. An electroscope consists of a jar with a pair of gold leaves. When the gold leaves are brought into contact with a charged object, the two leaves acquire the same charges and repel each other forming a deflection angle between them. This deflection angle is proportional to the amount of charge; that is $\frac{Q}{\theta} = \text{constant}$ where Q is charge and θ is the deflection angle. The constant can be determined from a single pair of charge and deflection angle. And then the charge can be obtained by measuring the deflection angle.

There are two ways by which an object can be charged, they are called conduction and induction.

Conduction is a process by which the charged object is brought in contact with the neutral object transferring charge of the same sign to the neutral object. *Induction* is a process by which a charged object is brought closer to a grounded neutral object and then the neutral object is disconnected from the ground. In this process the neutral charge acquires charge opposite to that of the charging object.

Substances are classified into two based on whether they have free (valence) electrons or not. Substances with free electrons are called *conductors* and substances without free electrons are called *insulators*. Conductors are good conductors of heat and electricity, shiny and ductile. Insulators are bad conductors of heat and electricity, dull and brittle.

Coulomb's Law

Coulomb's law states that any two charged objects exert electrical force on each other which is directly proportional to the product of their charges and inversely proportional to the square of the distance separating them. The line of the action of the force is along the line joining the centers of the charges. Let the point charge exerting force and the point charge that is being acted upon be denoted by q_1 and q_0 respectively. Let the position vectors of q_1 and q_0 with respect to a certain coordinate system be \vec{r}_1 and \vec{r}_0 . The distance between the charges (r_{01}) is the magnitude of the vector whose tail is located at q_1 and whose head is located at q_0 . In other words it is the magnitude of the vector $\vec{r}_{01} = \vec{r}_0 - \vec{r}_1$. That is, $r_{01} = |\vec{r}_0 - \vec{r}_1|$. Now the magnitude of the electrical force (F_{01}) exerted by q_1 on q_0 may be written as

$$F_{01} = \frac{k|q_1||q_0|}{|\vec{r}_0 - \vec{r}_1|^2}$$

Where k stands for a universal constant called Coulomb's constant.

$$k = 9 \times 10^9 \text{ Nm}^2/\text{C}^2$$

If the charges have the same sign, then the force is repulsive and will have the same direction as $\vec{r}_{01} = \vec{r}_0 - \vec{r}_1$. If the charges have opposite signs the force is attractive and the direction is opposite to that of $\vec{r}_{01} = \vec{r}_0 - \vec{r}_1$. If \vec{e}_{01} is a unit vector in the direction of \vec{r}_{01} (that is, $\vec{e}_{01} = \frac{\vec{r}_{01}}{r_{01}}$), then the direction of the unit vector in the direction of the electrical force exerted by q_1 on q_0 may generally be given as $\frac{q_1 q_0}{|q_1||q_0|} \vec{e}_{01}$, and the vector form of the electrical force becomes $\vec{F}_{01} = \frac{k|q_1||q_0|}{|\vec{r}_0 - \vec{r}_1|^2} \frac{q_1 q_0}{|q_1||q_0|} \vec{e}_{01}$ which reduces to

$$\vec{F}_{01} = \frac{kq_1 q_0}{|\vec{r}_0 - \vec{r}_1|^2} \vec{e}_{01}$$

And replacing \vec{e}_{01} by $\frac{\vec{r}_0 - \vec{r}_1}{|\vec{r}_0 - \vec{r}_1|}$, this also may be written as

$$\vec{F}_{01} = \frac{kq_1 q_0}{|\vec{r}_0 - \vec{r}_1|^3} (\vec{r}_0 - \vec{r}_1)$$

Remember if $\vec{r}_0 = (x_0, y_0, z_0)$ and $\vec{r}_1 = (x_1, y_1, z_1)$, then $|\vec{r}_0 - \vec{r}_1| = \sqrt{(x_0 - x_1)^2 + (y_0 - y_1)^2 + (z_0 - z_1)^2}$.

Example: Consider a $2\mu\text{C}$ charge located at the origin and a $-4\mu\text{C}$ charge located on the x-axis at $x = 0.002\text{ m}$.

a) Determine the electric force exerted by the $2\mu\text{C}$ charge on $-4\mu\text{C}$ charge.

Solution:

$$q_0 = -4 \times 10^{-6}\text{ C}; q_1 = 2 \times 10^{-6}\text{ C}; \vec{r}_0 = 0.002\hat{i}\text{ m}; \vec{r}_1 = 0; \vec{F}_{01} = ?$$

$$\vec{r}_0 - \vec{r}_1 = 0.002\hat{i}\text{ m}$$

$$|\vec{r}_0 - \vec{r}_1| = 0.002\text{ m}$$

$$\vec{F}_{01} = \frac{kq_1 q_0}{|\vec{r}_0 - \vec{r}_1|^3} (\vec{r}_0 - \vec{r}_1) = \frac{9 \times 10^9 \times 2 \times 10^{-6} \times (-4 \times 10^{-10})}{0.002^3} \times 0.002\text{ N} = -18 \times 10^3 \hat{i}\text{ N}$$

b) Determine the electric force exerted by the $-4 \mu\text{C}$ charge on the $2 \mu\text{C}$.

Solution

$$q_1 = -4 \times 10^{-6} \text{ C}; q_0 = 2 \times 10^{-6} \text{ C}; \vec{r}_0 = 0\hat{i} \text{ m}; \vec{r}_1 = 0.002\hat{i} \text{ m}; \vec{F}_{01} = ?$$

$$\vec{r}_0 - \vec{r}_1 = -0.002\hat{i} \text{ m}$$

$$|\vec{r}_0 - \vec{r}_1| = 0.002 \text{ m}$$

$$\vec{F}_{01} = 18 \times 10^{-3} \hat{i} \text{ N}$$

The two forces are action reaction forces. They have the same magnitude but opposite direction.

The superposition principle for electric forces

If a charge is in the vicinity of a number of charges, the net force acting on the charge is the vector sum of all of the individual forces due to the individual charges.

If charge q_0 is in the vicinity of charges q_1, q_2, q_3, \dots , then the net force (\vec{F}_0) acting on charge q_0 is given by

$$\vec{F}_0 = \frac{kq_1q_0}{|\vec{r}_0 - \vec{r}_1|^3}(\vec{r}_0 - \vec{r}_1) + \frac{kq_2q_0}{|\vec{r}_0 - \vec{r}_2|^3}(\vec{r}_0 - \vec{r}_2) + \frac{kq_3q_0}{|\vec{r}_0 - \vec{r}_3|^3}(\vec{r}_0 - \vec{r}_3) + \dots = \sum_{i=1} \frac{kq_iq_0}{|\vec{r}_0 - \vec{r}_i|^3}(\vec{r}_0 - \vec{r}_i)$$

Example: Consider three charged particles of charge $-2 \mu\text{C}$, 4 and $6 \mu\text{C}$ placed on the y -axis at $y = 0.004 \text{ m}$, $y = 0$ and $y = -0.002$ respectively. Calculate the net electrical force exerted on the $-2 \mu\text{C}$ charge.

Solution:

$$q_0 = -2 \times 10^{-6} \text{ C}; \vec{r}_0 = 0.004\hat{j} \text{ m}; q_1 = 4 \times 10^{-6} \text{ C}; \vec{r}_1 = 0; q_2 = 6 \times 10^{-6} \text{ C}; \vec{r}_2 = -0.002\hat{j} \text{ m}; \vec{F}_0 = ?$$

$$\begin{aligned} \vec{F}_0 &= \frac{kq_1q_0}{|\vec{r}_0 - \vec{r}_1|^3}(\vec{r}_0 - \vec{r}_1) + \frac{kq_2q_0}{|\vec{r}_0 - \vec{r}_2|^3}(\vec{r}_0 - \vec{r}_2) = kq_0 \left(\frac{q_1}{|\vec{r}_0 - \vec{r}_1|^3}(\vec{r}_0 - \vec{r}_1) + \frac{q_2}{|\vec{r}_0 - \vec{r}_2|^3}(\vec{r}_0 - \vec{r}_2) \right) \\ &= 9 \times 10^9 \times -2 \times 10^{-6} \left(\frac{4 \times 10^{-6}}{4^3} (0.004\hat{j}) + \frac{6 \times 10^{-6}}{6^3} (0.006\hat{j}) \right) \text{ N} = -4.5 \times 10^{-3} \hat{j} \text{ N} \end{aligned}$$

Example: Consider three charged particles of charges 4 nC, -3 nC and -2 nC placed at the points (0,0) m, (0.004,0) m, and (0.002,0.003) respectively. Calculate the net force exerted on the -3 nC charge by the other charges.

Solution:

$$q_0 = -3 \times 10^{-9} \text{ C}; \vec{r}_0 = 0.004\hat{i} \text{ m}; q_1 = 4 \times 10^{-9} \text{ C}; \vec{r}_1 = 0; q_2 = -2 \times 10^{-9} \text{ m}; \vec{r}_2 = (0.002\hat{i} + 0.003\hat{j}) \text{ m}; \vec{F}_0 = ?$$

$$\vec{r}_0 - \vec{r}_1 = 0.004\hat{i} \text{ m}; \vec{r}_0 - \vec{r}_2 = (0.002\hat{i} - 0.003\hat{j}) \text{ m}$$

$$|\vec{r}_0 - \vec{r}_1| = 0.004 \text{ m}; |\vec{r}_0 - \vec{r}_2| = \sqrt{0.002^2 + (-0.003)^2} \text{ m} = 0.0036 \text{ m}$$

$$\begin{aligned} \vec{F}_0 &= \frac{kq_1q_0}{|\vec{r}_0 - \vec{r}_1|^3}(\vec{r}_0 - \vec{r}_1) + \frac{kq_2q_0}{|\vec{r}_0 - \vec{r}_2|^3}(\vec{r}_0 - \vec{r}_2) = kq_0 \left(\frac{q_1}{|\vec{r}_0 - \vec{r}_1|^3}(\vec{r}_0 - \vec{r}_1) + \frac{q_2}{|\vec{r}_0 - \vec{r}_2|^3}(\vec{r}_0 - \vec{r}_2) \right) \\ &= 9 \times 10^9 \times (-2 \times 10^{-9}) \left(\frac{4 \times 10^{-9}}{0.004^3} 0.004\hat{i} + \frac{-2 \times 10^{-9}}{0.0036^3} (0.002\hat{i} - 0.003\hat{j}) \right) \text{ N} = (-0.003\hat{i} - 0.0023\hat{j}) \text{ N} \end{aligned}$$

Example: A 2 μC charge is located at the origin. A 4 μC charge is located on the x -axis at $x=10$ mm. Where should a third particle whose charge is -5 μC be placed if the net force exerted on it is to be zero?

Solution: It should be located between the charges if the force is to be zero

$$q_1 = 2 \times 10^{-6} \text{ C}; \vec{r}_1 = 0; q_2 = 4 \times 10^{-6} \text{ C}; \vec{r}_2 = 0.01\hat{i} \text{ m}; \vec{F}_0 = 0; q_0 = -5 \times 10^{-6} \text{ C}; \vec{r}_0 = ?$$

$$\vec{r}_0 - \vec{r}_1 = x_0\hat{i}; \vec{r}_0 - \vec{r}_2 = (x_0 - 0.01)\hat{i} \text{ m}$$

$$|\vec{r}_0 - \vec{r}_1| = x_0; |\vec{r}_0 - \vec{r}_2| = 0.01 \text{ m} - x_0$$

$$\begin{aligned} \vec{F}_0 &= \frac{kq_1q_0}{|\vec{r}_0 - \vec{r}_1|^3}(\vec{r}_0 - \vec{r}_1) + \frac{kq_2q_0}{|\vec{r}_0 - \vec{r}_2|^3}(\vec{r}_0 - \vec{r}_2) = 0 \\ \frac{2 \times 10^{-6}}{x_0^3} x_0\hat{i} + \frac{4 \times 10^{-6}}{(0.01 - x_0)^3} (x_0 - 0.01 \text{ m})\hat{i} &= 0 \end{aligned}$$

$$\frac{2}{x_0^2} = \frac{4}{(0.01 \text{ m} - x_0)^2}$$

$$2(0.01 \text{ m} - x_0)^2 = x_0^2$$

$$x_0^2 + .02x_0 \text{ m} - .0001 \text{ m}^2 = 0$$

Selecting the solution that make sense

$$x_0 = \frac{-0.02 + \sqrt{(0.02)^2 - 4(-0.0001)}}{2} \text{ m} = 0.004 \text{ m}$$

Practice Quiz 1.1

Choose the best answer

1. What is the unit of measurement for charge?
 - A. Coulomb
 - B. Volt
 - C. Newton
 - D. Watt
 - E. Ampere
2. Which of the following is not a correct statement?
 - A. Insulators are not good conductors of heat.
 - B. An object charged by induction acquires a charge opposite to that of the charging object.
 - C. An object charged by conduction acquires the same charge as the charging object.
 - D. Conduction is a charging process where a neutral object is brought closer to a charged object and then grounded.
 - E. Electrical force is the kind of force that arises when objects are rubbed together.
3. A positive charge **A** is placed on the x-axis at $x = 11$ m. A positive charge **B** is placed on the x-axis at $x = 12$ m. Determine the direction of the electrical force exerted by charge **B** on charge **A**.
 - A. South
 - B. East
 - C. North
 - D. West
 - E. North east
4. A $-5e-9$ C charge **A** is placed on the x-axis at $x = 0.003$ m. A $-4e-9$ c charge **B** is placed on the x-axis at $x = 0.008$ m. Determine the magnitude and direction of the electrical force exerted by charge **A** on charge **B**.
 - A. $7.2e-3$ N West
 - B. $8.64e-3$ N West
 - C. $6.48e-3$ N West
 - D. $7.2e-3$ N East
 - E. $6.48e-3$ N East

5. Object **A** of charge $-4e-6$ C is located on the x-axis at $x = 0.005$ m. Object **B** of charge $-1e-6$ C is located on the x-axis at $x = 0.009$ m. Object **C** of charge $5e-6$ C is located on the x-axis at $x = 0.011$ m. Determine the magnitude and direction of the net electrical force exerted on object **C** by objects **A** and **B**.
- A. 16250 N West
 - B. 13000 N East
 - C. 17875 N West
 - D. 17875 N East
 - E. 16250 N East
6. Object **A** of charge $-5e-6$ C is located on the x-axis at $x = 0.004$ m. Object **B** of charge $1e-6$ C is located on the x-axis at $x = 0.006$ m. Object **C** of charge $-3e-6$ C is located on the x-axis at $x = 0.012$ m. Determine the magnitude and direction of the net electrical force exerted on object **B** by objects **A** and **C**.
- A. 10498.9 N West
 - B. 10500 N West
 - C. 10500 N East
 - D. 10502.2 N West
 - E. 10498.9 N East



Discover the truth at www.deloitte.ca/careers

Deloitte.

© Deloitte & Touche LLP and affiliated entities.

7. Object **A** of charge $-1e-6$ C is located at the origin of a coordinate plane. Object **B** of charge $1e-6$ C is located on the x-axis of a coordinate plane at $x = 0.002$ m. Object **C** of charge $1e-6$ C is located on the y-axis of a coordinate plane at $y = 0.001$ m. Calculate the direction (angle formed with the positive x-axis) of the net electrical force exerted on object **A** by objects **B** and **C**.
- A. 106.349°
 - B. 60.771°
 - C. 98.753°
 - D. 68.367°
 - E. 75.964°
8. Object **A** of charge $-3e-6$ C is located at the origin of a coordinate plane. Object **B** of charge $2e-6$ C is located on the x-axis of a coordinate plane at $x = 0.005$ m. Object **C** of charge $3e-6$ C is located on the y-axis of a coordinate plane at $y = 0.003$ m. Calculate the magnitude of the net electrical force exerted on object **A** by objects **B** and **C**.
- A. 11106.686 N
 - B. 12957.8 N
 - C. 12032.243 N
 - D. 9255.571 N
 - E. 8330.014 N
9. Object **A** of charge $5e-6$ C is located on the x-axis of a coordinate plane at $x = 0.004$ m. Object **B** of charge $5e-6$ C is located on the y-axis of a coordinate plane at $y = 0.004$ m. Object **C** of charge $-1e-6$ C is located on the y-axis of a coordinate plane at $y = -0.005$ m. Calculate the magnitude of the net electrical force exerted on object **A** by objects **B** and **C**.
- A. 9405.71 N
 - B. 6511.646 N
 - C. 7235.162 N
 - D. 10129.227 N
 - E. 8682.194 N

10. Object **A** of charge $3e-6$ C is located on the x-axis of a coordinate plane at $x = 0.004$ m. Object **B** of charge $3e-6$ C is located on the y-axis of a coordinate plane at $y = 0.003$ m. Object **C** of charge $-2e-6$ C is located on the y-axis of a coordinate plane at $y = -0.001$ m. Calculate the direction (angle with respect to the positive x-axis) of the net electrical force exerted on object **A** by objects **B** and **C**.
- A. 258.43°
B. 259.775°
C. 256.553°
D. 264.516°
E. 262.018°

Electric Fields

Instead of saying charge q_1 exerts electrical force on charge q_2 , in field theory, we say q_1 sets up electric field throughout space and this field exerts force on charge q_2 . *Electric field* (\vec{E}) at a given point is defined to be the electric force (\vec{F}_e) exerted per unit charge on a charge (q) placed at the given point.

$$\vec{E} = \frac{\vec{F}_e}{q}$$

If q is a positive charge then the electric force and electric field at the given point have the same direction. And if the charge is negative, they have opposite directions. The unit of measurement for electric field is N/C. Experimentally, electric field at a given point can be determined by measuring the electric force on a small charge placed at the point and then obtaining the ratio between the force and the charge. The equation relating the magnitude of the force (F) and the electric field (E) is obtained by taking the magnitude of both sides of the equation $\vec{F}_e = q\vec{E}$.

$$F_e = |q|E$$

Example: Determine the electric field at point P if $q = -6$ nC charge placed at the point experience a force of $12 \mu\text{N}$ 37° North of East.

Solution:

$$q = -6 \times 10^{-9} \text{ C}; F = 12 \mu\text{N}; \theta = 37^\circ; \vec{E} = ?$$

$$\begin{aligned}\vec{F} &= F \cos(\theta)\hat{i} + F \sin(\theta)\hat{j} \\ &= (12 \times 10^{-6} \text{ N})\cos(37^\circ)\hat{i} + (12 \times 10^{-6} \text{ N})\sin(37^\circ)\hat{j}\end{aligned}$$

$$= 9.6 \times 10^{-6} \hat{i} + 7.2 \times 10^{-6} \hat{j}$$

$$\vec{E} = \frac{\vec{F}}{q} = \frac{9.6 \times 10^{-6} \hat{i} + 7.2 \times 10^{-6} \hat{j}}{-6 \times 10^{-9}} \text{ N/C}$$

$$= (-1.6 \times 10^3 \hat{i} - 1.2 \times 10^3 \hat{j}) \text{ N/C}$$

Electric field due to a point charge

Consider a point at a distance r from a point charge q . Now suppose a small positive test charge q' is placed at the. Then, according to Coulomb's law, the electrical force exerted on q' by q is given by

$\vec{F}_{q'} = k \frac{qq'}{r^3} \vec{r}$ where \vec{r} is the position vector of the point with respect to the charge. Therefore the electric field at the point ($\vec{E} = \frac{\vec{F}_{q'}}{q'}$) due to the point charge q is given by $\vec{E} = \frac{kq}{r^3} \vec{r}$. The position vector \vec{r} can be written in terms of the unit vector (\hat{e}_r) in the direction of the position vector as $\vec{r} = r\hat{e}_r$. Thus, the electric field due to a point charge may also be given as

$$\vec{E} = \frac{kq}{r^2} \hat{e}_r$$

SIMPLY CLEVER

ŠKODA



We will turn your CV into
an opportunity of a lifetime



Do you like cars? Would you like to be a part of a successful brand?
We will appreciate and reward both your enthusiasm and talent.
Send us your CV. You will be surprised where it can take you.

Send us your CV on
www.employerforlife.com



Download free eBooks at bookboon.com

Click on the ad to read more

If the position vectors of the charge and the point are \vec{r} and \vec{r}_0 respectively, then the position vector of the point with respect to the charge is $\vec{r}_0 - \vec{r}$ and the expression for the electric field becomes

$$\vec{E} = \frac{kq}{|\vec{r}_0 - \vec{r}|^3} (\vec{r}_0 - \vec{r})$$

If the charge q is positive, the direction of the electric field is directed radially outward from the charge. If q is negative the direction of the field is directed radially towards the charge.

Example: Determine the electric field at the point (0.003, 0.004) due to a $-8 \mu\text{C}$ point charge located at the origin.

Solution:

$$q = -8 \times 10^{-6}; \vec{r} = 0; \vec{r}_0 = (0.003\hat{i} + 0.004\hat{j}) \text{ m}; \vec{E} = ?$$

$$\vec{r}_0 - \vec{r} = (0.003\hat{i} + 0.004\hat{j}) \text{ m}; |\vec{r}_0 - \vec{r}| = \sqrt{0.003^2 + 0.004^2} \text{ m} = 0.005 \text{ m}$$

$$\vec{E} = \frac{kq}{|\vec{r}_0 - \vec{r}|^3} (\vec{r}_0 - \vec{r}) = \frac{9 \times 10^9 \times -8 \times 10^{-6}}{0.005^3} (0.003\hat{i} + 0.004\hat{j}) \text{ N/C} = (-1.728\hat{i} - 2.304\hat{j}) \times 10^3 \text{ N/C}$$

Superposition Principle

If there are a number of charges in the vicinity of a point, then the net electric field at the point is equal to the vector sum of all the electric fields due to all the individual charges. If charges q_1, q_2, \dots whose position vectors are $\vec{r}_1, \vec{r}_2, \vec{r}_3, \dots$ respectively are in the vicinity of a point whose position vector is \vec{r}_0 , then the net electric field at the point is given by

$$\vec{E}_0 = k \left(\frac{kq_1}{|\vec{r}_0 - \vec{r}_1|^3} (\vec{r}_0 - \vec{r}_1) + \frac{kq_2}{|\vec{r}_0 - \vec{r}_2|^3} (\vec{r}_0 - \vec{r}_2) + \frac{kq_3}{|\vec{r}_0 - \vec{r}_3|^3} (\vec{r}_0 - \vec{r}_3) + \dots \right) = k \sum_i \frac{kq_i}{|\vec{r}_0 - \vec{r}_i|^3} (\vec{r}_0 - \vec{r}_i)$$

Example: Consider the charges $q_1 = 2 \mu\text{C}$, $q_2 = -3 \mu\text{C}$ and $q_3 = 4 \mu\text{C}$ q_2 is located 8 mm to the right of q_1 . q_3 is located 2 mm to the right of q_2 . Calculate the net electric field at a point located 3 mm to the right of q_1 .

Solution: Let's use a coordinate system where the 3 charged lie on the x-axis whose origin is the point where the electric field is to be calculated. Then

$$\vec{r}_0 = 0, \vec{r}_1 = -0.003\hat{i} \text{ m}, \vec{r}_2 = 0.005\hat{i} \text{ m}, \vec{r}_3 = 0.007\hat{i} \text{ m}, \vec{r}_0 - \vec{r}_1 = 0.003\hat{i} \text{ m}, \vec{r}_0 - \vec{r}_2 = -0.005\hat{i} \text{ m}, \vec{r}_0 - \vec{r}_3 = -0.007\hat{i} \text{ m},$$

$$|\vec{r}_0 - \vec{r}_1| = 0.003 \text{ m}, |\vec{r}_0 - \vec{r}_2| = 0.005 \text{ m} \text{ and } |\vec{r}_0 - \vec{r}_3| = 0.007 \text{ m}. \text{ Therefore}$$

$$\vec{E}_0 = k \left(\frac{q_1 (\vec{r}_0 - \vec{r}_1)}{|\vec{r}_0 - \vec{r}_1|^3} + \frac{q_2 (\vec{r}_0 - \vec{r}_2)}{|\vec{r}_0 - \vec{r}_2|^3} + \frac{q_3 (\vec{r}_0 - \vec{r}_3)}{|\vec{r}_0 - \vec{r}_3|^3} \right)$$

$$= 9 \times 10^9 \left(\frac{2 \times 10^{-6} (0.003 \hat{i})}{0.003^3} + \frac{-3 \times 10^{-6} (-0.005 \hat{i})}{0.005^3} + \frac{4 \times 10^{-6} (-0.007 \hat{i})}{0.007^3} \right) \text{ N/C} = 2.345 \times 10^9 \hat{i} \text{ N/C}$$

Example: Consider two charges $q_1 = 5 \mu\text{C}$ located on the y-axis at $y = 0.005 \text{ m}$ and $q_2 = 2 \mu\text{C}$ located on the y-axis at $y = -0.005 \text{ m}$. Calculate the net electric field located on the x-axis at $y = -0.005 \text{ m}$.

Solution:

$$\vec{r}_0 = 0.005 \hat{i} \text{ m}; q_1 = 5 \times 10^{-6} \text{ C}; \vec{r}_1 = 0.005 \hat{j} \text{ m}; q_2 = -2 \times 10^{-6} \text{ C}; \vec{r}_2 = -0.005 \hat{j} \text{ m};$$

$$\vec{r}_0 - \vec{r}_1 = (0.005 \hat{i} - 0.005 \hat{j}) \text{ m}; \vec{r}_0 - \vec{r}_2 = (0.005 \hat{i} + 0.005 \hat{j}) \text{ m}; |\vec{r}_0 - \vec{r}_1| = |\vec{r}_0 - \vec{r}_2| = 0.005\sqrt{2} \text{ m}; \vec{E}_0 = ?$$

$$\begin{aligned} \vec{E}_0 &= k \left(\frac{q_1 (\vec{r}_0 - \vec{r}_1)}{|\vec{r}_0 - \vec{r}_1|^2} + \frac{q_2 (\vec{r}_0 - \vec{r}_2)}{|\vec{r}_0 - \vec{r}_2|^2} \right) \\ &= 9 \times 10^9 \left(\frac{5 \times 10^{-6} (0.005 \hat{i} - 0.005 \hat{j})}{(0.005\sqrt{2})^2} + \frac{-2 \times 10^{-6} (0.005 \hat{i} + 0.005 \hat{j})}{(0.005\sqrt{2})^2} \right) \text{ N/C} = (0.6429 \times 10^9 \hat{i} - 0.6429 \times 10^9 \hat{j}) \text{ N/C} \end{aligned}$$

Electric Field due to a Continuous Distribution of Charges

Suppose the charge contained in a small volume element dV is dq , then the electric field ($d\vec{E}$) due to dq at point P , whose position vector with respect to the location of dq is \vec{r}_p , is given as $d\vec{E} = k \frac{dq}{r_p^2} \vec{r}_p$.

The total electric field at point P is obtained by adding (*integrating*) the electric fields due to all dq 's in the distribution: $\vec{E} = \int k \frac{dq}{r_p^2} \vec{r}_p$. This integral over charge element dq can be converted into an integral over volume by defining a charge density ρ as $\rho = \frac{dq}{dV}$. Then $dq = \rho dV$ and the integral over position can be written as $\vec{E} = k \int_V \frac{\vec{r}_p \rho}{r_p^3} dV$. If \vec{r} and \vec{r}' are position vectors of point P and charge dq with respect to a certain coordinate system respectively, then $\vec{r}_p = \vec{r} - \vec{r}'$, $r_p = |\vec{r} - \vec{r}'|$ and $dV = dV'$ (to emphasize that the integral is over \vec{r}' and not over \vec{r}). Now the integral can be written in terms of these variables as

$$\vec{E} = \int \frac{k \rho (\vec{r} - \vec{r}') dV'}{|\vec{r} - \vec{r}'|^3}$$

Linear charge density $\left(\frac{dq}{dx}\right)$ and areal density $\left(\frac{dq}{dA}\right)$ are customarily represented by the symbols λ and σ respectively. Therefore for linear and areal charge distributions, the formula for the electric field can be written as $\vec{E} = \int \frac{k\lambda(\vec{r}-\vec{r}')dx'}{|\vec{r}-\vec{r}'|^3}$ and $\vec{E} = \int \frac{k\sigma(\vec{r}-\vec{r}')dA'}{|\vec{r}-\vec{r}'|^3}$ respectively.

Example: Consider a uniformly charged rod of total charge Q that extends on the x -axis from $x = a$ to $x = a + L$. Calculate the net electric field at the origin due to this charge distribution.

Solution: Since it is uniformly charged $\lambda = \frac{Q}{L}$. Let dx' be an arbitrary path element on the rod a distance of x' from the origin. Then $\vec{r} = 0$ (because the point where the electric field is to be calculated is at the origin) $\vec{r}' = x'\hat{i}$ where the value of x' varies from a to L , $\vec{r} - \vec{r}' = -x'\hat{i}$ and $|\vec{r} - \vec{r}'| = x'$. Therefore $\vec{E} = \int \frac{k\lambda(\vec{r}-\vec{r}')ds'}{|\vec{r}-\vec{r}'|^3} = \frac{-kQ\hat{i}}{L} \int_a^{a+L} \frac{dx'}{x'^2} = \frac{-kQ}{a(a+L)}\hat{i}$.

Example: A uniformly charged ring of radius R and total charge Q is on the xy -plane centered at the origin. Find an expression for the electric field due to this charge distribution at an arbitrary point on the z -axis.

I joined MITAS because
I wanted **real responsibility**

The Graduate Programme
for Engineers and Geoscientists
www.discovermitas.com



Month 16

I was a construction
supervisor in
the North Sea
advising and
helping foremen
solve problems

Real work
International opportunities
Three work placements



 **MAERSK**

Solution: Since, it is uniformly charged $\lambda = \frac{Q}{2\pi R}$. Let ds' be an arbitrary small arc length path element on the ring. Let the coordinate of the point on the z-axis where the electric field is to be evaluated be $(0, 0, z)$. Then $\vec{r} = z\hat{k}$, $\vec{r}' = R\cos(\phi)\hat{i} + R\sin(\phi)\hat{j}$ (where ϕ is the angle formed between \vec{r}' and the positive x-axis), $\vec{r} - \vec{r}' = z\hat{k} - R\cos\phi\hat{i} - R\sin\phi\hat{j}$, $|\vec{r} - \vec{r}'| = (z^2 + R^2)^{\frac{1}{2}}$ and $ds = Rd\phi$.

$$\text{Therefore } \vec{E} = \int \frac{k\lambda(\vec{r} - \vec{r}') ds'}{|\vec{r} - \vec{r}'|^3} = \frac{kQ}{2\pi R} \frac{1}{(x^2 + R^2)^{\frac{3}{2}}} \left\{ \hat{i} \int_0^{2\pi} R\cos\phi [Rd\phi] - \hat{j} \int_0^{2\pi} R\sin\phi [Rd\phi] + \hat{k} \int_0^{2\pi} z [Rd\phi] \right\}$$

The \hat{i} and \hat{j} terms vanish because the integrals of cosine and sine over a full revolution are zero and

$$\vec{E} = \frac{kQz}{(x^2 + R^2)^{\frac{3}{2}}} \hat{k}$$

Example: Consider a rod that extends from $x = 0$ to $x = 2$ m on the x-axis. The charge density in the rod varies on x according to the equation $\lambda(x) = 2\sqrt{8-x}$. Calculate the electric field due to this charged rod at a point located at $x = 8$ m.

Solution: Let dx' be an arbitrary path element on the rod a distance of x' from the origin. Therefore $\lambda(x) = 2\sqrt{8-x}$, $\vec{r} = 8\hat{i}$ m, $\vec{r}' = x'\hat{i}$, $\vec{r} - \vec{r}' = (8 - x')\hat{i}$ and $|\vec{r} - \vec{r}'| = (8 - x')$ and

$$\vec{E} = \int_{x=0}^{x=2} k \frac{2\sqrt{8-x}}{(8-x)^2} dx \hat{i} = -2k \hat{i} \int_0^2 (8-x)^{-3/2} d(8-x) = 2 \times 10^8 \hat{i} \text{ N/C}$$

Electric Field Lines

Electric field lines are lines used to represent electric field graphically. These lines should represent both magnitude and direction of the field at any point. To represent magnitude, they are drawn in such a way that the number of lines crossing a unit perpendicular area (density of lines) is directly proportional to the magnitude of the field at any point. To represent direction, these lines are drawn in such a way that the line of action of the field is tangent to the curves at any point. To distinguish between the two possible directions of the tangent line, arrows are included in the lines. Electric field lines originate in a positive charge and sink in a negative charge. Electric field lines do not cross each other. Because if they do, that would mean two tangent lines at the intersection point and hence two directions for a field at the intersection point which is not possible.

Practice Quiz 1.2

Choose the best answer

- Which of the following is a correct statement?
 - The direction of the electric field due to a positive point charge is directed towards the charge.
 - The direction of the electric force on a positive charge is opposite to the direction of the electric field at its location.
 - The unit of measurement for electric field is Newton / Coulomb
 - The magnitude of the electric field due to a point charge is inversely proportional to the distance between the charge and the point.
 - There is no electric field at a point where there is no charge.
- Which of the following is a correct statement?
 - The line of action of an electric field at a given point is perpendicular to the line tangent to the electric field line at the given point.
 - The denser the electric field lines, the greater the magnitude of the electric field.
 - The electric field lines due to a negative charge are directed away from the charge
 - Electric field lines originate from a negative charge and sink in a positive charge.
 - It is possible for electric field lines to cross each other.
- Calculate the magnitude and direction of the electric force exerted on a -9 C charge located at a point where the electric field is 95 N/C north.
 - 855 N north
 - 940.5 N south
 - 940.5 N north
 - 684 N east
 - 855 N south
- A $-3e-9\text{ C}$ charge A is placed on the x-axis at $x = 1.1\text{ m}$. Point P is located on the x-axis at $x = 0.8\text{ m}$. Determine the magnitude and direction of the electric field at point P due to charge A .
 - 270 N/C West
 - 300 N/C East
 - 360 N/C West
 - 270 N/C East
 - 300 N/C West

5. Object **A** of charge $1e-9$ C is located on the x-axis at $x = 0.1$ m. Object **B** of charge $5e-9$ C is located on the x-axis at $x = 0.6$ m. Point **P** is located on the x-axis at $x = 1.1$ m. Determine the magnitude and direction of the net electricfield at point **P** due to objects **A** and **B**.
- A. 207.9 N/C West
B. 189 N/C West
C. 226.8 N/C West
D. 207.9 N/C East
E. 189 N/C East
6. Object **A** of charge $-4e-9$ C is located on the x-axis at $x = 0.4$ m. Object **B** of charge $3e-9$ C is located on the x-axis at $x = 0.8$ m. Point **P** of is located on the x-axis at $x = 1.1$ m. Determine the magnitude and direction of the net electric field point **P** by objects **A** and **B**.
- A. 226.531 N/C West
B. 225.531 N/C East
C. 224.531 N/C West
D. 225.531 N/C West
E. 226.531 N/C East

ie business school

#1 EUROPEAN BUSINESS SCHOOL
FINANCIAL TIMES 2013

#gobeyond

MASTER IN MANAGEMENT

Because achieving your dreams is your greatest challenge. IE Business School's Master in Management taught in English, Spanish or bilingually, trains young high performance professionals at the beginning of their career through an innovative and stimulating program that will help them reach their full potential.

- Choose your area of specialization.
- Customize your master through the different options offered.
- Global Immersion Weeks in locations such as London, Silicon Valley or Shanghai.

Because you change, we change with you.

www.ie.edu/master-management | mim.admissions@ie.edu |

7. Point P is located at the origin of a coordinate plane. Object A of charge $5e-9$ C is located on the x-axis of a coordinate plane at $x = 0.1$ m. Object B of charge $-2e-9$ C is located on the y-axis of a coordinate plane at $y = 0.5$ m. Calculate the direction (angle formed with the positive x-axis) of the net electric field at point P due to objects A and B .
- A. -0.825°
 - B. 179.083°
 - C. 161.175°
 - D. 214.9°
 - E. -0.917°
8. Point P is located at the origin of a coordinate plane. Object A of charge $-3e-9$ C is located on the x-axis of a coordinate plane at $x = 0.3$ m. Object B of charge $4e-9$ C is located on the y-axis of a coordinate plane at $y = 0.5$ m. Calculate the magnitude of the net electric field at point P due to objects A and B .
- A. 332.77 N/C
 - B. 299.493 N/C
 - C. 465.878 N/C
 - D. 232.939 N/C
 - E. 399.324 N/C
9. Point P is located on the x-axis of a coordinate plane at $x = 0.2$ m. Object A of charge $3e-9$ C is located on the y-axis of a coordinate plane at $y = 0.2$ m. Object B of charge $-1e-9$ C is located on the y-axis of a coordinate plane at $y = -0.4$ m. Calculate the magnitude of the net electric field at point P due to objects A and B .
- A. 496.036 N/C
 - B. 460.605 N/C
 - C. 283.449 N/C
 - D. 318.88 N/C
 - E. 354.312 N/C

10. Point P is located on the x -axis of a coordinate plane at $x = 0.4$ m. Object A of charge $5e-9$ C is located on the y -axis of a coordinate plane at $y = 0.2$ m. Object B of charge $-3e-9$ C is located on the y -axis of a coordinate plane at $y = -0.3$ m. Calculate the direction (angle with respect to the positive x -axis) of the net electric field at point P due to objects A and B .
- A. -59.629°
 - B. -58.529°
 - C. -56.329°
 - D. -55.229°
 - E. -53.029°
11. An object of charge 8 C is located at the origin. An object of charge -3.5 C is located at $x = 10$ m. The electric field due to these charges will be zero at $x = ?$
- A. 20.676 m
 - B. 23.629 m
 - C. 17.722 m
 - D. 29.537 m
 - E. 26.583 m
12. The charge density of a rod that extends from the origin to 3 m varies on x according to the equation
- $$\lambda(x) = 4e-9(10 - x)0.6$$
- Calculate the electric field at a point located at $x = 10$ m
- A. 5.494 N/C
 - B. 4.396 N/C
 - C. 6.044 N/C
 - D. 7.143 N/C
 - E. 7.692 N/C

2 GAUSS'S LAW

Your goal for this chapter is to learn how to get expressions for the electric field due to symmetric charge distributions using Gauss's law.

Electric Flux

Area: Area is a vector quantity. The direction of area is perpendicular to the plane of the area. To distinguish between the two possible directions (perpendicularly in and perpendicularly out) the right hand rule is used. When fingers of the right hand are wrapped along its perimeter in a counterclockwise direction, then the direction of the thumb represents the direction of the area. The direction of the area is usually the direction pointing towards you. For a closed surface, the direction of area is directed outward from the closed surface. The direction perpendicularly in is represented by a cross (\times) and the direction perpendicularly out is represented by a dot (\odot). For example, the direction of a loop that lies in the xy -plane is \hat{k} .



"I studied English for 16 years but...
...I finally learned to speak it in just six lessons"

Jane, Chinese architect

ENGLISH OUT THERE

Click to hear me talking before and after my unique course download

Electric flux (ϕ_E) is defined to be a measure of the amount of electric field that crosses a certain area perpendicularly. The electric flux crossing a small area element dA is defined to be the product of the area element and the component of the electric field perpendicular to the plane of the area or parallel to $d\vec{A}$. In other words, it is the dot product between the electric field (\vec{E}) and the area element $d\vec{A}$.

$$d\phi_E = \vec{E} \cdot d\vec{A}$$

If the angle formed between \vec{E} and $d\vec{A}$ is θ , then also

$$d\phi_E = E \cdot dA \cos\theta$$

The unit of measurement for electric flux is $\frac{\text{N}}{\text{C}}\text{m}^2$ which is defined to be the Weber abbreviated as Wb. To find the electric flux crossing a certain area \vec{A} , first the area is divided into small area elements and then the contribution to the flux from each small area element are added (integrated).

$$\phi_E = \int \vec{E} \cdot d\vec{A} = \int E(\cos\theta) dA$$

Electric flux crossing a certain area is equal to the surface integral of the electric field over the area. If the electric field and the angle between the field and the area element are constant everywhere, then $\phi_E = \int E(\cos\theta) dA = E \cos(\theta) \int dA$ and the expression for the electric flux simplifies to

$$\phi_E = EA \cos(\theta) = \vec{E} \cdot \vec{A}$$

Electric flux is a scalar quantity. It can be positive (when $\theta = 90^\circ$), zero (when $\theta = 90^\circ$) and negative (when $90^\circ < \theta \leq 180^\circ$).

Example: In each of the following, calculate the electric flux crossing the region. The magnitude of the electric field crossing the area is 100 N/C.

a) A circular region of radius 2 m where the electric field is parallel to the plane of the square.

Solution: Since the direction of the area is a (g) or perpendicularly out $\theta = 90^\circ$.

$$E = 100 \text{ N/C}; r = 2 \text{ m } (A = \pi r^2); \phi_E = ?$$

$$\phi_E = EA \cos(\theta)$$

$$A = \pi r^2 = \pi \times 2^2 \text{ m}^2 = 4\pi \text{ m}^2$$

$$\phi_E = (100)(4\pi)\cos(90^\circ) = 0$$

b) A square region of side 4 m where the electric field is directed perpendicularly into the plane of the region.

Solution: Since the direction of the area is perpendicularly out and the field is perpendicularly in, $\theta = 180^\circ$.

$$E = 100 \text{ N/C}; w = 2 \text{ m } (A = w^2); \phi_E = ?$$

$$\phi_E = EA \cos(\theta)$$

$$A = w^2 = 4^2 \text{ m}^2 = 16 \text{ m}^2$$

$$\phi_E = (100)(16)\cos(180^\circ) \text{ Web} = -1600 \text{ N m}^2/\text{C}$$

c) A triangular region of height 3 m and width 6 m where the field is directed perpendicularly out of the plane of the region.

Solution: Since the direction of both the area and field are perpendicularly out, $\theta = 0^\circ$.

$$E = 100 \text{ N/C}; w = 6 \text{ m}; h = 3 \text{ m } \left(A = \frac{1}{2}hw \right); \phi_E = ?$$

$$\phi_E = EA \cos(\theta)$$

$$A = \frac{1}{2}hw = \frac{1}{2} \times 6 \times 3 \text{ m}^2 = 9 \text{ m}^2$$

$$\phi_E = (100)(9)\cos(0^\circ) = 900 \text{ N m}^2/\text{C}$$

Gauss's Law

Gauss's law States that the total electric flux crossing a closed surface is equal to $4\pi k$ times the total charge (q) enclosed inside the closed surface (k is Coulomb's constant). Mathematically, Gauss's law can be written as

$$\oint_{\text{closed surface}} \vec{E} \cdot d\vec{A} = 4\pi kq = \frac{q}{\epsilon_0}$$

Where $\epsilon_0 = \frac{1}{4\pi k} = 8.85 \times 10^{-12} \frac{\text{C}^2}{\text{Nm}^2}$ is electric permittivity of vacuum or approximately air.

Proof: To make the discussion easier, let's consider the flux due a positive point charge on a spherical surface centered at the charge.

Let the radius of the Gaussian surface be R . Consider a small area element $d\vec{A}$, on the Gaussian surface. At this area element the directions of both $d\vec{A}$ and \vec{E} are radially outward.

Excellent Economics and Business programmes at:



university of
 groningen



**“The perfect start
of a successful,
international career.”**

CLICK HERE
to discover why both socially
and academically the University
of Groningen is one of the best
places for a student to be

www.rug.nl/feb/education

That is $d\vec{A} = dA\hat{e}_r$ and $\vec{E} = E\hat{e}_r$ where $\hat{e}_r = \frac{\vec{r}}{r}$ is a radially outward unit vector. $d\phi_E = \vec{E} \cdot d\vec{A} = EdA$,

and $\int_{\text{closed surface}} \vec{E} \cdot d\vec{A} = \int_{\text{closed surface}} EdA$. But from Coulomb's law $E = \frac{kq}{4\pi R^2}$. $\int_{\text{closed surface}} \vec{E} \cdot d\vec{A} = \frac{kq}{4\pi R^2} \int_{\text{closed surface}} dA$.

But $\int_{\text{closed surface}} dA$ is equal to the surface area of the spherical Gaussian surface which is equal to

$4\pi R^2$. Therefore it follows that $\int_{\text{closed surface}} \vec{E} \cdot d\vec{A} = 4\pi kq = \frac{q}{\epsilon_0}$.

Example: Three particles of charges 2 nC, -6 nC and 9 nC are located on the x-axis at the points $x = 1$, cm; $x = 3$ cm and $x = 5$ cm respectively. Calculate the electric flux crossing a Gaussian surface of radius 4 cm centered at the origin.

Solution: Only the 2 nC and the -6 nC charges are enclosed by the Gaussian surface. Therefore the total charge enclosed inside the Gaussian surface is -4 nC.

$$q = -4 \times 10^{-9} \text{ C}; \phi_E = ?$$

$$\phi_E = 4\pi kq = 4\pi \times 9 \times 10^{-9} (-4 \times 10^{-9}) \text{ Web} = 4.52 \times 10^{-16} \text{ N m}^2/\text{C}$$

Example: Consider a rectangular prism Gaussian surface whose corners are located on the points A(0,0,0) m, B(1,0, 0) m, C(1,2,0) m, D(0,2,0)m , E(0,0,1) m, F(1,0,1) m, G(0,2,1) m H(0,2,1) m. If there is an electric field of $\vec{E} = 0.004 \text{ N/C} \hat{j}$ for $y \geq 1$ m and $\vec{E} = -0.002 \text{ N/C} \hat{j}$ for $y < 1$ m.

a) Calculate the electric flux crossing each surface.

Solution

The fluxes crossing surfaces ABCD, EFGH, BCGF. EHDA and FGCB are zero because the electric field is perpendicular to the area.

On surface AEFB, $\vec{A} = 1 \text{ m}^2 \hat{j}$ and $\vec{E} = 0.004 \text{ N/C} \hat{j}$. Therefore the flux $(\vec{E} \cdot \vec{A})$ is $0.002 \text{ N m}^2/\text{C}$.

On surface CDHG $\vec{A} = 1 \text{ m}^2 \hat{j}$ and $\vec{E} = 0.004 \text{ N/C} \hat{j}$. Therefore the flux $(\vec{E} \cdot \vec{A})$ is $0.004 \text{ N m}^2/\text{C}$.

b) Calculate the total flux crossing the closed Gaussian surface.

Solution: The total flux crossing the closed surface is the sum of the fluxes crossing the faces of the rectangular prism. Therefore the total flux is $0.006 \text{ N m}^2/\text{C}$.

c) Calculate the total charge enclosed inside the Gaussian surface.

Solution

$$\phi_{\text{closed surface}} = 4\pi k q_{\text{total}} = 0.006 \text{ N m}^2/\text{C}$$

$$q_{\text{total}} = \frac{0.006}{4\pi k} \text{ C} = 5.3 \times 10^{-14} \text{ C}$$

Example: Consider a closed cylindrical Gaussian surface of radius 0.2 m and length 0.6 m. The electric field is parallel to the axis of the cylinder everywhere. If the total charge enclosed inside the closed surface is $8 \times 10^{-13} \text{ C}$ and the electric flux crossing the left end is 0.005 Web, calculate the flux crossing the right end.

Solution: $\phi_{\text{curved surface}} = 0$, because the electric field is perpendicular to the area on the curved surface everywhere.

$$\phi_{\text{left end surface}} = 0.005 \text{ Web}; q_{\text{total}} = 8 \times 10^{-13} \text{ C}; \phi_{\text{right end surface}} = ?$$

$$\phi_{\text{closed surface}} = \phi_{\text{left end surface}} + \phi_{\text{right end surface}} + \phi_{\text{curved surface}} = 4\pi k q_{\text{total}}$$

$$0.005 \text{ Wb} + \phi_{\text{right end surface}} = 4 \times 9 \times 10^9 \times 8 \times 10^{-13} \pi \text{ N m}^2/\text{C} = 0.009 \text{ N m}^2/\text{C}$$

$$\phi_{\text{right end surface}} = 0.004 \text{ N m}^2/\text{C}$$

Example: The electric field in a certain region varies with the distance from the origin according to the equation $\vec{E}(r) = -5r^{0.5} \hat{e}_r$; where \hat{e}_r is a unit vector in the direction of the position vector. Calculate the total charge enclosed inside a spherical surface of radius 0.2 m centered at the origin.

Solution: On the spherical surface $r = 0.2$ m. Therefore the electric field on the surface is $\vec{E}(r=0.2 \text{ m}) = -5\sqrt{0.2}\hat{e}_r = -2.24\hat{e}_r$. The direction of the area is along the position vector everywhere. Thus $d\vec{A} = dA\hat{e}_r$,

$$d\phi_E = \vec{E} \cdot d\vec{A} = (-2.24\hat{e}_r) \cdot (dA\hat{e}_r) = -2.24dA$$

$$\phi_{\text{closed surface}} = -2.24 \int_{\text{spherical surface}} dA = -2.24(4\pi[0.2^2]) = -1.13 \text{ N m}^2/\text{C} = 4\pi kq_{\text{total}}$$

$$q_{\text{total}} = \frac{-1.3 \text{ N m}^2/\text{C}}{4\pi k} = \underline{-1.15 \times 10^{-7} \text{ C}}$$

Example: The electric field in a certain region varies with the perpendicular distance from the x-axis according to the equation $\vec{E}(r_{\perp}) = \frac{4}{r_{\perp}}\hat{e}_{\perp}$, where \hat{e}_{\perp} is a unit vector radially perpendicular to the x-axis. Calculate the total charge enclosed inside a cylindrical surface of radius 0.07 m and length 0.3 m whose axis lies along the x-axis.

American online LIGS University

is currently enrolling in the
Interactive Online **BBA, MBA, MSc,**
DBA and PhD programs:

- ▶ enroll **by September 30th, 2014** and
- ▶ **save up to 16%** on the tuition!
- ▶ pay in 10 installments / 2 years
- ▶ Interactive Online education
- ▶ visit www.ligsuniversity.com to find out more!

Note: LIGS University is not accredited by any nationally recognized accrediting agency listed by the US Secretary of Education. More info [here](#).



Solution:

$$R = 0.07 \text{ m}; \ell = 0.3 \text{ m}; q_{\text{total}} = ?$$

On the end surfaces the direction of the area is parallel to the axis. Therefore the flux is zero since the area and the field are perpendicular to each other. On the curved surface, the direction of the area is radially perpendicular to the axis everywhere. That is, $d\vec{A} = dA\hat{e}_{\perp}$. r_{\perp} on the curved surface is 0.07 m. Therefore the electric field on the curved surface is $\vec{E}(r_{\perp} = 0.07 \text{ m}) = \frac{4}{0.07}\hat{e}_{\perp} \text{ N/C} = 57.14\hat{e}_{\perp} \text{ N/C}$.

$$d\phi_E = \vec{E} \cdot d\vec{A} = (57.14\hat{e}_{\perp} \text{ N/C}) \cdot (dA\hat{e}_{\perp}) = 57.14dA \text{ N/C}$$

$$\phi_{\text{closed surface}} = \int_{\text{curved surface}} d\phi_E = 57.14 \int dA \text{ N/C} = 4\pi k q_{\text{total}}$$

$$q_{\text{total}} = \frac{1}{4\pi k} 57.14 \int_{\text{curved surface}} dA \text{ N/C} = \frac{57.14}{4\pi k} (2\pi R\ell) \text{ N/C} = \frac{57.14(2\pi \times 0.07 \times 0.3)}{4\pi \times 9 \times 10^9} \text{ C} = 6.7 \times 10^{-11} \text{ C}$$

Practice Quiz 2.1

Choose the best answer

- Which of the following is a correct statement?
 - Electric flux is a vector quantity.
 - The unit of measurement of electric flux is Newton / Coulomb.
 - Gauss's law states that the electric flux crossing a certain closed surface is proportional to the amount of charge enclosed by the surface.
 - Area is a scalar quantity.
 - If the electric field that crosses a certain area is perpendicular to the plane of the loop, then the electric flux crossing the surface is zero
- The corners of a cubical surface are located at the following points of an xyz coordinate system:

A (0, 0, 0), B (1, 0, 0),
 C (1, 1, 0), D (0, 1, 0),
 E (0, 0, 1), F (1, 0, 1),
 G (1, 1, 1), H (0, 1, 1).

 Determine the direction of face CDHGC.
 - \mathbf{j}
 - $-\mathbf{j}$
 - $-\mathbf{k}$
 - $-\mathbf{i}$
 - \mathbf{i}

3. Consider a spherical surface centered at the origin of an xyz coordinate system. Determine the direction of an infinitesimally small area element ($d\mathbf{A}$) located at the intersection point of the spherical surface and the negative x -axis.
- A. $-\mathbf{k}$
 - B. \mathbf{i}
 - C. $-\mathbf{i}$
 - D. $-\mathbf{j}$
 - E. \mathbf{j}

4. The corners of a rectangular prism are located at the following points of an xyz coordinate system:
- A $(0, 0, 0)$, B $(1.2, 0, 0)$ m,
 - C $(1.2, 12.7, 0)$ m, D $(0, 12.7, 0)$ m,
 - E $(0, 0, 1.2)$ m, F $(1.2, 0, 1.2)$ m,
 - G $(1.2, 12.7, 1.2)$ m, H $(0, 12.7, 1.2)$ m.

If there is an electric field of $(0.037 \mathbf{i} - 0.73 \mathbf{j})$ N/C everywhere, Calculate the electric flux crossing face CDHGC.

- A. -1.051 N m²/C
 - B. 0.053 N m²/C
 - C. -0.053 N m²/C
 - D. 22.25 N m²/C
 - E. 1.051 N m²/C
5. Consider a closed cylindrical surface of radius 5.2 m and length 16.2 . Its axis is along the x -axis. If there is an electric field of $(-0.048 \mathbf{i})$ N/C everywhere, calculate the electric flux that crosses the curved surface.
- A. 0
 - B. -25.406 N m²/C
 - C. 22.866 N m²/C
 - D. 25.406 N m²/C
 - E. -22.866 N m²/C

6. Consider a closed cylindrical surface of radius 0.91 m and length 1.2 m whose axis lies along the z -axis. The electric field at a point depends on the perpendicular distance between the axis and the point (ρ) according to the equation

$$\mathbf{E}(\rho) = 17.4/\rho^3 \mathbf{e}_\rho$$

where \mathbf{e}_ρ at a given point is a unit vector in the direction of the line that passes through the point and is perpendicular to the axis (in other words its direction is perpendicularly radially outward from the axis). Calculate the total electric flux that crosses the closed cylinder.⁴

- A. 142.584 N m²/C
- B. 221.797 N m²/C
- C. 205.954 N m²/C
- D. 158.426 N m²/C
- E. 190.112 N m²/C

.....Alcatel-Lucent 

www.alcatel-lucent.com/careers



What if you could build your future and create the future?

One generation's transformation is the next's status quo. In the near future, people may soon think it's strange that devices ever had to be "plugged in." To obtain that status, there needs to be "The Shift".

7. Calculate the electric flux crossing a certain closed surface of an arbitrary shape if 4 protons and 11 electrons are enclosed inside the closed surface.
- $126.669 \times 10^{-9} \text{ N m}^2 / \text{C}$
 - $-126.669 \times 10^{-9} \text{ N m}^2 / \text{C}$
 - $-271.434 \times 10^{-9} \text{ N m}^2 / \text{C}$
 - $271.434 \times 10^{-9} \text{ N m}^2 / \text{C}$
 - $298.577 \times 10^{-9} \text{ N m}^2 / \text{C}$
8. The corners of a rectangular prism are located at the following points of an xyz coordinate system:
- A $(0, 0, 0)$, B $(0.6, 0, 0)$ m,
 C $(0.6, 1.3, 0)$ m, D $(0, 1.3, 0)$ m,
 E $(0, 0, 0.6)$ m, F $(0.6, 0, 0.6)$ m,
 G $(0.6, 1.3, 0.6)$ m, H $(0, 1.3, 0.6)$ m.
- The electric field is zero for all points whose x -coordinate is less than 0.5 m and $0.26 \text{ N/C } \hat{i}$ for all points whose x -coordinate is greater or equal than 0.5 m. Calculate the charge enclosed inside the surfaces of the rectangular prism.
- $-1.972 \times 10^{-12} \text{ C}$
 - 0
 - $1.793 \times 10^{-12} \text{ C}$
 - $1.972 \times 10^{-12} \text{ C}$
 - $-1.793 \times 10^{-12} \text{ C}$
9. There is an electric field of $-25.9 \text{ N/C } \hat{i}$ on all points whose x -coordinate is less than or equal to zero and an electric field of $25.9 \text{ N/C } \hat{i}$ on all points whose x -coordinate is greater than zero. Calculate the charge enclosed inside a closed cylindrical surface of radius 0.4 m whose axis extends from $x = -1.5$ m to $x = 1.5$ m.
- $230.222 \times 10^{-12} \text{ C}$
 - $-253.244 \times 10^{-12} \text{ C}$
 - $-230.222 \times 10^{-12} \text{ C}$
 - 0
 - $253.244 \times 10^{-12} \text{ C}$

10. The electric field at an arbitrary point depends on the perpendicular distance between the z-axis and the point (ρ) according to the equation

$$\mathbf{E}(\rho) = (1.2/\rho) \mathbf{e}_\rho$$

where \mathbf{e}_ρ at a given point is a unit vector in the direction of the line that passes through the point and is perpendicular to the axis (in other words its direction is perpendicularly radially outward from the axis). Calculate the charge enclosed inside a closed cylindrical surface of radius 0.5 m and length 4.9 m whose axis lies along the z-axis. Cylinder.

- A. $228.667e-12$ C
 B. $457.333e-12$ C
 C. $294e-12$ C
 D. $326.667e-12$ C
 E. $261.333e-12$ C

Application of Gauss's Law

Gauss's law is often used to get an expression for the electric field due to a symmetric distribution of charges as a function of distance.

Electric Field due to a positive point Charge

Even though Gauss's law is applicable for any closed surface, a suitable Gaussian surface that takes advantage of the symmetry of the problem should be chosen in order to simplify the problem. For the field due to a point charge, a Gaussian surface that takes advantage of the following two facts should be chosen: a) the direction of the electric field due to a point charge is along the position vector of the point with respect to the charge b) from symmetry, the magnitude of the electric field due to a point charge on a spherical surface centered at the point charge is a constant.

A Gaussian surface that can take advantage of these two facts is a spherical surface centered at the charge. Because the direction of the area at any point is along its radius or along the position vector of the point with respect to its center. Let's apply Gauss's law over a spherical surface of radius r centered at the charge. $d\vec{A} = dA \hat{e}_r$ and $\vec{E} = E\hat{e}_r$ (assuming positive charge). Therefore $\oint \vec{E} \cdot d\vec{A} = \oint E dA = E \oint dA = 4\pi E r^2 = 4\pi kq$ and the electric field due to a point charge as a function of radial distance is given by

$$E = \frac{kq}{r^2}$$

And the vector electric field is $\vec{E} = E\hat{e}_r = \frac{kq}{r^2} \hat{e}_r = \frac{kq}{r^2} \frac{\vec{r}}{r} = \frac{kq}{r^3} \vec{r}$ where \vec{r} is a position vector.

Electric field due to a uniformly charged spherical object

Let the radius of the charged spherical object be R and let its total charge be Q .

Electric field for points outside the spherical object ($r > R$): From symmetry, the direction of the electric is radially outward from the center of the sphere everywhere; and its magnitude is constant on any spherical surface concentric with the sphere. To take advantage of this symmetry, let the Gaussian surface be a spherical surface of radius $r > R$. Then $d\vec{A} = dA \hat{e}_r$, and $\vec{E} = E\hat{e}_r$ (assuming positive charge) and $\oint \vec{E} \cdot d\vec{A} = \oint E dA = E \oint dA = 4\pi E r^2 = 4\pi kq$. Therefore the electric field due to a uniformly charged spherical object for points outside the sphere is given by

$$E = \frac{kQ}{R^3} r$$

And the vector electric field is $\vec{E} = E\hat{e}_r = kQ \frac{r}{R^3} \hat{e}_r = kQ \frac{r}{R^3} \frac{\vec{r}}{r} = \frac{kQ}{R^3} \vec{r}$ where \vec{r} is a position vector.

In the past four years we have drilled

81,000 km

That's more than **twice** around the world.

Who are we?
We are the world's leading oilfield services company. Working globally—often in remote and challenging locations—we invent, design, engineer, manufacture, apply, and maintain technology to help customers find and produce oil and gas safely.

Who are we looking for?
We offer countless opportunities in the following domains:

- **Engineering, Research, and Operations**
- **Geoscience and Petrotechnical**
- **Commercial and Business**

If you are a self-motivated graduate looking for a dynamic career, apply to join our team.

careers.slb.com

What will you be?

Schlumberger

Electric field for points inside the spherical object ($r > R$): From symmetry, the electric field is radial and constant on a spherical surface centered at the center of the charged sphere. To take advantage of this symmetry, the Gaussian surface is taken to be a spherical surface concentric with the spherical object of radius $r < R$. Only a fraction of the total charge is enclosed inside this Gaussian surface. The enclosed charge can be calculated as a product of the charge density $\left(\frac{Q}{\frac{4}{3}\pi R^3}\right)$ and the volume of the Gaussian surface $\left(\frac{4}{3}\pi r^3\right)$. That is, the enclosed charge is equal to $Q\left(\frac{r}{R}\right)^3$. $d\vec{A} = dA \hat{e}_r$ and $\vec{E} = E\hat{e}_r$; and $\oint \vec{E} \cdot d\vec{A} = \oint E dA = E \oint dA = 4\pi E r^2 = 4\pi kQ \left(\frac{r}{R}\right)^3$.

Therefore the magnitude of the electric field inside the spherical object is given by

$$E = \frac{kQ}{R^3} r$$

And the vector electric field is $\vec{E} = E\hat{e}_r = kQ \frac{r}{R^3} \hat{e}_r = kQ \frac{r}{R^3} \frac{\vec{r}}{r} = \frac{kQ}{R^3} \vec{r}$ where \vec{r} is a position vector.

The expressions for the electric field for inside and outside points may be written as

$$E = \begin{cases} \frac{kQ}{r^2} & \text{if } r > R \\ E = \frac{kQ}{R^3} r & \text{if } r < R \end{cases}$$

Example: A solid sphere of radius 0.1m is uniformly charged and has a charge of $2 \times 10^{-3} \text{C}$.

a) Calculate the strength of the field at a distance 0.2 m from the center of the sphere.

Solution:

$$r = 0.2 \text{ m}, \quad R = 0.1 \text{ m}, \quad Q = 2 \times 10^{-3} \text{ C}$$

Since $r > R$

$$E = \frac{kQ}{r^2} = \frac{(9 \times 10^9)(2 \times 10^{-3})}{(0.2)^2} \text{ N/C} = 4.5 \times 10^8 \text{ N/C}$$

b) Calculate the strength of the field at a distance of 0.01m from the center of the sphere.

Solution:

$$r = 0.2 \text{ m}, \quad R = 0.1 \text{ m}, \quad Q = 2 \times 10^{-3} \text{ C}$$

Since $r < R$

$$E = \frac{kQ}{R^3} r = \frac{(9 \times 10^9)(2 \times 10^{-3})}{(0.1)^3} (0.01) \text{ N/C} = 1.8 \times 10^8 \text{ N/C}$$

c) Calculate the electric field vector at the point (2, 4, 1) m.

Solution:

$$\vec{r} = (2\hat{i} + 4\hat{j} + \hat{k}) \text{ m}, \quad R = 0.1 \text{ m}, \quad Q = 2 \times 10^{-3} \text{ C}$$

$$r = \sqrt{2^2 + 4^2 + 1^2} \text{ m} = \sqrt{21} \text{ m}$$

Since $r > 0.1 \text{ m}$,

$$\begin{aligned} \vec{E} &= \frac{kQ}{r^2} \hat{e}_r = \frac{kQ}{r^3} \vec{r} \\ \vec{E} &= \frac{9 \times 10^9 \times 2 \times 10^{-3}}{\sqrt{21}^3} (2\hat{i} + 4\hat{j} + \hat{k}) \text{ N/C} \\ \vec{E} &= (3.74 \times 10^5 \hat{i} + 7.48 \times 10^5 \hat{j} + 1.87 \times 10^5 \hat{k}) \text{ N/C} \end{aligned}$$

Electric field due to an infinitely long uniformly charged thin rod

Since it is infinitely long, any point in the wire can be assumed to be the mid-point. Thus the component of the field parallel to the rod due to any charge in the wire will be cancelled by the component of the field parallel to the rod due to a charge on the other side. Thus, the component of the field parallel to the rod at any point is zero. In other words, the direction of the field is radially perpendicular to the rod. Again, because of symmetry, all points at the same perpendicular distance from the rod will have the same magnitude for the electric field. To take advantage of these symmetries, The Gaussian surface is taken to be a cylinder of radius r_{\perp} and length ℓ concentric with the rod. Let the charge density be λ . Then the total charge enclosed inside the Gaussian surface is $\lambda\ell$.

The electric flux of the end faces are zero because the area is perpendicular to the field.

On the surface, the area element $d\vec{A}$ and \vec{E} (assuming a positive charge) have the same

directions. Therefore $\phi_E = \oint \vec{E} \cdot d\vec{A} = \int_{\text{curved surface}} \vec{E} \cdot d\vec{A} = \int_{\text{curved surface}} E dA = 2\pi r_{\perp} \ell E = 4\pi k \lambda \ell$. And the magnitude

of the electric field as function of the perpendicular distance from the rod is given as

$$E = \frac{2k\lambda}{r_{\perp}}$$

Therefore, $\vec{E} = \frac{2k\lambda}{r_{\perp}} \hat{e}_{r_{\perp}} = \frac{2k\lambda}{r_{\perp}} \frac{\vec{r}_{\perp}}{r_{\perp}} = \frac{2k\lambda}{r_{\perp}^2} \vec{r}_{\perp}$ where \vec{r}_{\perp} is the radially perpendicular (to the rod) component of the position vector ($\vec{r} = r_{\parallel} \hat{e}_{\parallel} + r_{\perp} \hat{e}_{\perp}$).

Example: Consider an infinitely long thin rod of charge density $2 \mu\text{C}/\text{m}^2$ that lies along the x-axis.



Join the best at
the Maastricht University
School of Business and
Economics!

Top master's programmes

- 33rd place Financial Times worldwide ranking: MSc International Business
- 1st place: MSc International Business
- 1st place: MSc Financial Economics
- 2nd place: MSc Management of Learning
- 2nd place: MSc Economics
- 2nd place: MSc Econometrics and Operations Research
- 2nd place: MSc Global Supply Chain Management and Change

Sources: Keuzegids Master ranking 2013; Elsevier 'Beste Studies' ranking 2012; Financial Times Global Masters in Management ranking 2012

Maastricht University is the best specialist university in the Netherlands (Elsevier)

Visit us and find out why we are the best!
Master's Open Day: 22 February 2014

www.mastersopenday.nl



a) Calculate the electric field at a point which is located at a perpendicular distance of 2mm from the rod.

Solution:

$$r_{\perp} = 0.002 \text{ m}, \quad \lambda = 2 \times 10^{-6} \text{ C}; \quad E = ?$$

$$E = \frac{k\lambda}{2\pi r_{\perp}} = \frac{(9 \times 10^9)(2 \times 10^{-6})}{2\pi(0.002)} \text{ N/C} = 1.4 \times 10^6 \text{ N/C}$$

b) Calculate the electric field vector at the point (-1, 2, 4) m.

Solution:

$$\vec{r} = (-\hat{i} + 2\hat{j} + 4\hat{k}) \text{ m}; \quad \vec{E} = ?$$

$\vec{r} = \vec{r}_{\parallel} + \vec{r}_{\perp}$, where r_{\parallel} is the component of the position vector along the rod and r_{\perp} is a component of the position vector perpendicular to the rod. Since the rod lies along the x-axis $\vec{r}_{\parallel} = x\hat{i}$. Therefore $\vec{r}_{\perp} = \vec{r} - \vec{r}_{\parallel} = (x\hat{i} + y\hat{j} + z\hat{k}) - x\hat{i} = y\hat{j} + z\hat{k} = (2\hat{j} + 4\hat{k}) \text{ m}$

$$r_{\perp} = \sqrt{2^2 + 4^2} \text{ m} = \sqrt{20} \text{ m}$$

$$\vec{E} = \frac{2k\lambda}{r_{\perp}} \hat{e}_{r_{\perp}} = \frac{2k\lambda}{r_{\perp}} \frac{\vec{r}_{\perp}}{r_{\perp}} = \frac{2k\lambda}{r_{\perp}^2} \vec{r}_{\perp} = \frac{2 \times 9 \times 10^9 \times 2 \times 10^{-6}}{\sqrt{20}^2} (2\hat{j} + 4\hat{k}) \text{ N/C} = \underline{(3.6 \times 10^3 \hat{j} + 7.2 \times 10^3 \hat{k}) \text{ N/C}}$$

Electric field due to a uniformly charged infinitely large plane (assume positive charge)

From symmetry, the component of the electric field parallel to the plane will be zero at any point. Thus, the direction of the field at any point is perpendicular to the plane everywhere. Also from symmetry, the magnitude of the field is constant for points located at plane parallel to the charged plane. To take advantage of these symmetries, the Gaussian surface is taken to be a cylindrical surface of base area A whose axis is perpendicular to the plane and encloses a part of the plane. If the charge density is σ , then the total charge enclosed inside the Gaussian surface is σA . The flux on the curved surface is zero because the field and the area are perpendicular to each other. The flux on each end face is EA because the field and the area are parallel to each other. Therefore the total flux crossing the Gaussian surface is $2EA$ and from Gauss's law it follows that $2EA = 4\pi k\sigma A$. Therefore the field due to an infinitely large plane is constant everywhere and is given by

$$E = 2\pi k\sigma = \frac{\sigma}{2\epsilon_0}$$

The vector field is $\vec{E} = 2\pi k\sigma \hat{e}_\perp = 2\pi k\sigma \frac{\vec{r}_\perp}{r_\perp}$ where \vec{r}_\perp is a component of the position vector perpendicular to the plane.

Example: Consider a uniformly charged infinite plane of charge density 2 C/m^2 that lies in the xy -plane. Calculate the electric field vector at the point $(2, 3, -5) \text{ m}$.

Solution:

$$\vec{r} = (2\hat{i} + 3\hat{j} - 5\hat{k}) \text{ m}; \sigma = 2 \text{ C/m}^2; \vec{E} = ?$$

Since the point lies below the xy -plane ($z = -5 \text{ m} < 0$),

$$\hat{e}_\perp = -\hat{k}$$

$$\vec{E} = 2\pi k\sigma \hat{e}_\perp = -2\pi \times 9 \times 10^9 \times 2 \times 10^{-6} \hat{k} \text{ N/C} = -36\pi \times 10^3 \hat{k} \text{ N/C}$$

Electric field due to a uniformly charged spherical shell

Let the radius of the shell be R .

Electric field for points inside the spherical shell ($r < R$): From symmetry, it can be concluded that the electric field on a concentric spherical Gaussian surface inside the sphere is uniform and radial. Then, if the radius of the Gaussian surface is $r < R$, then $\phi_{\text{closed surface}} = 4\pi r^2 E = 4\pi kq$. But, there are no charges inside the Gaussian surface (because the charges reside on the shell) and $q = 0$. It follows that the electric field inside a charged spherical shell is zero everywhere

$$E = 0$$

Electric field for points outside the spherical shell ($r > R$): From symmetry the field on a concentric spherical Gaussian surface of radius $r > R$ enclosing the charged shell is uniform and radial. If the charge density of the shell is σ , then the total charge enclosed by the Gaussian surface is $4\pi R^2 \sigma$. $d\vec{A} = dA \hat{e}_r$ and $\vec{E} = E \hat{e}_r$; and $\oint \vec{E} \cdot d\vec{A} = \oint E dA = E \oint dA = 4\pi E r^2 = 4\pi kQ$ where $Q = 4\pi R^2 \sigma$ is total charge on the shell. Therefore the magnitude of the electric field outside the shell is given by

$$E = \frac{kQ}{r^2}$$

And the vector electric field is $\vec{E} = E \hat{e}_r = \frac{kQ}{r^2} \hat{e}_r = \frac{kQ}{r^2} \frac{\vec{r}}{r} = \frac{kQ}{r^3} \vec{r}$ where \vec{r} is a position vector.

The electric field inside and outside can be combined together as

$$E = \begin{cases} 0 & \text{if } r < R \\ \frac{kQ}{r^2} & \text{if } r > R \end{cases}$$

Conductors in Electrostatic Equilibrium

Conductors are said to be in electrostatic equilibrium, if their free charges are at rest. The fact that the charges are at rest indicates that the electric field inside a conductor in electrostatic equilibrium must be zero. Because, if there was a non-zero field, the free charges would be moving.

Now let's consider a Gaussian surface inside a conductor in electrostatic equilibrium. Gauss's law implies that $\oint \vec{E} \cdot d\vec{A} = 4\pi kq$. But $\vec{E} = 0$ everywhere inside which implies q must be zero. Therefore there is no net excess charge inside a conductor in electrostatic equilibrium. If there is an excess charge, it must reside on the surface of the conductor. Since the charges are not moving on the surface of the conductor, the component of the electric field just outside the conductor in a direction parallel to the surface must be zero. Thus, the electric field just outside a conductor must be perpendicular to the surface of the conductor.



> **Apply now**

REDEFINE YOUR FUTURE
**AXA GLOBAL GRADUATE
PROGRAM 2015**

redefining / standards 

agence.cdg - © Photonistop

To find the magnitude of the electric field just outside the conductor in terms of the charge density (σ) on the surface, let's use a small cylindrical Gaussian surface enclosing a small surface area (dA) of the conductor with the axis of the cylinder being parallel to the direction of the area element. If the charge density of the surface charges is σ , then the charge enclosed by the Gaussian surface is σdA . The electric flux crossing the surface of cylinder inside the conductor is zero because $E = 0$ inside. The flux on the curved surface outside is zero because the electric field is parallel to the surface (or \perp to the area). The only contribution to the flux comes from the end face outside the conductor: $d\phi_E = EdA = 4\pi k\sigma A$. Therefore the magnitude of the electric just outside a conductor in electrostatic equilibrium is given by

$$E = 4\pi k\sigma = \frac{\sigma}{\epsilon_0}$$

And $\vec{E} = 4\pi k\sigma\hat{e}_\perp$ where \hat{e}_\perp is a unit vector perpendicular to the surface (outward) at the given location. Magnitude of the electric field just outside a conductor in electrostatic equilibrium is proportional to the charge and its direction is \perp to the surface. For a spherical conductor in electrostatic equilibrium, $\sigma = \frac{Q}{4\pi R^2}$ where Q is the total excess charge on the surface (From symmetry, the excess charges must be distributed uniformly on a spherical surface). It follows that $E = \frac{kQ}{R^2}$. This indicates that for a surface of irregular shape, the electric field is inversely proportional to the square of the radius of curvature of the surface. In other words, the electric field will be stronger at sharper parts of the surface than at dull parts of the surfaces. And since the electric field is proportional to the charge density, it follows that the charge density at shaper parts of the surface is greater than that of the dull parts of the surface.

Practice Quiz 2.2

Choose the best answer

1. Which of the following cannot be deduced from symmetry considerations about the electric field due to a uniformly charged spherical object (assume the charge is positive)?
 - A. The electric field on a spherical surface concentric with the spherical object has no component in a direction that is tangent to the surface
 - B. All of the other choices can be deduced from symmetry
 - C. The direction of the field at any point is in the direction of the position vector of the point with respect to the center of the spherical object.

- D. The angle formed between the position vector (with respect to the center of the spherical object) and infinitesimally small area element at any point on a spherical surface concentric with the sphere is 90° .
- E. The magnitude of the electric field is constant on any spherical surface concentric with the spherical object
2. Which of the following cannot be deduced from symmetry considerations about the electric field due to an infinitely long straight uniformly charged rod (assume the charge is positive)?
- A. All of the other choices can be deduced from symmetry.
- B. The angle between the electric field and an infinitesimally small area element at a any point on the end faces of the surface of a cylinder concentric with the rod is zero.
- C. The magnitude of the electric field is a constant on the curved part of a cylindrical surface concentric with the rod.
- D. The angle between the electric field and an infinitesimally small area element at a any point on the curved surface of a cylinder concentric with the rod is zero.
- E. The direction of the electric field is perpendicular to the rod everywhere.
3. Which of the following cannot be deduced from symmetry considerations about the electric field due to a uniformly charged plane that extends in all directions infinitely (assume the charge is positive)?
- A. The magnitude of the electric field is constant everywhere
- B. The angle between the electric field and an infinitesimally small area element at any point on the end faces of a cylinder whose axis is perpendicular to the plane is zero.
- C. The direction of the electric field is parallel to the plane everywhere.
- D. The angle between the electric field and an infinitesimally small area element at any point on a curved surface of a cylinder whose axis is perpendicular to the plane is 90°
- E. All of the other choices can be deduced from symmetry.
4. Calculate the charge density of a uniformly charged sphere of radius 0.54 m centered at the origin if the magnitude of the electric field at the point $(18.2, 3.2, 2.8)$ m is 5.3 N/C.
- A. $0.405e-6$ C/m³
- B. $0.25e-6$ C/m³
- C. $0.281e-6$ C/m³
- D. $0.187e-6$ C/m³
- E. $0.312e-6$ C/m³

5. Calculate the electric field due to a uniformly charged sphere of radius 0.46 m and charge density $5.3e-6$ C/m³ (centered at the origin) at the point $(18.2, 1.5, 2.8)$ m.
- A. $(61.742 \mathbf{i} + 5.089 \mathbf{j} + 8.635 \mathbf{k})$ N/C
B. $(72.968 \mathbf{i} + 2.776 \mathbf{j} + 6.908 \mathbf{k})$ N/C
C. $(56.129 \mathbf{i} + 5.089 \mathbf{j} + 6.908 \mathbf{k})$ N/C
D. $(72.968 \mathbf{i} + 4.626 \mathbf{j} + 6.908 \mathbf{k})$ N/C
E. $(56.129 \mathbf{i} + 4.626 \mathbf{j} + 8.635 \mathbf{k})$ N/C
6. Calculate the magnitude of the electric field due to a uniformly charged sphere of radius 0.24 m and charge density $5.3e-6$ C/m³ (centered at the origin) at the point $(4.5e-3, 3.4e-3, 5.3e-3)$ m.
- A. 1082.476 N/C
B. 1391.755 N/C
C. 1546.395 N/C
D. 2164.953 N/C
E. 1855.674 N/C



The logo for BI Norwegian Business School features a central blue square with the letters 'BI' in white. Radiating from this center are numerous colorful, 3D-style rectangular bars in various colors (red, orange, yellow, green, blue, purple, pink). Each bar has a label for a business program: 'Business', 'Strategic Marketing Management', 'International Business', 'Leadership & Organisational Psychology', 'Shipping Management', and 'Financial Economics'.

Empowering People. Improving Business.

BI Norwegian Business School is one of Europe's largest business schools welcoming more than 20,000 students. Our programmes provide a stimulating and multi-cultural learning environment with an international outlook ultimately providing students with professional skills to meet the increasing needs of businesses.

BI offers four different two-year, full-time Master of Science (MSc) programmes that are taught entirely in English and have been designed to provide professional skills to meet the increasing need of businesses. The MSc programmes provide a stimulating and multi-cultural learning environment to give you the best platform to launch into your career.

- MSc in Business
- MSc in Financial Economics
- MSc in Strategic Marketing Management
- MSc in Leadership and Organisational Psychology

BI NORWEGIAN BUSINESS SCHOOL

EFMD
EQUIS
ACCREDITED

www.bi.edu/master

7. Calculate the charge density of an infinitely long rod that lies along the z-axis if the magnitude of the electric field at the point $(16.3, 7.4, 3.2)$ m is $3.2e3$ N/C.
- $3.819e-6$ C/m
 - $1.909e-6$ C/m
 - $3.182e-6$ C/m
 - $2.228e-6$ C/m
 - $2.864e-6$ C/m
8. Calculate the electric field due to an infinitely long uniformly charged rod of charge density $9.1e-6$ C/m that lies along the z-axis at the point $(12.5, 6.1, 1.5)$ m.
- $(10.584e3 \mathbf{i} + 5.165e3 \mathbf{j})$ N/C
 - $(11.642e3 \mathbf{i} + 3.615e3 \mathbf{j})$ N/C
 - $(7.409e3 \mathbf{i} + 3.099e3 \mathbf{j})$ N/C
 - $(11.642e3 \mathbf{i} + 5.165e3 \mathbf{j})$ N/C
 - $(10.584e3 \mathbf{i} + 4.132e3 \mathbf{j})$ N/C
9. Calculate the charge density of a uniformly charged plane (that extends infinitely in all directions) that lies on the xy-plane if the magnitude of the field at the point $(17.1, 4.8, 5.3)$ m is $3.2e5$ N/C (assume positively charged).
- $4.527e-6$ C/m²
 - $5.093e-6$ C/m²
 - $3.395e-6$ C/m²
 - $7.356e-6$ C/m²
 - $5.659e-6$ C/m²
10. Calculate the magnitude of the electric field due to a uniformly charged and infinitely long cylindrical shell (open on both ends) of radius 0.24 m and charge density $8.5e-6$ C/m² at a point located at a perpendicular distance of 6.1 m from the axis of the cylindrical shell.
- 34040.444 N/C
 - 30258.172 N/C
 - 0
 - 26475.901 N/C
 - 37822.715 N/C

11. Calculate the magnitude of the electric field due to a uniformly charged infinitely long solid cylindrical cable of radius 0.81 m and charge density $3.2 \times 10^{-6} \text{ C/m}^3$ at a point located at a perpendicular distance of 3.2 m from the axis of the cylinder.
- A. 0
 - B. 29681.265 N/C
 - C. 37101.581 N/C
 - D. 48232.055 N/C
 - E. 40811.739 N/C
12. The electric field between two oppositely charged parallel plates is a constant and perpendicular to the plates. The electric field outside the plates is approximately zero. If the charge density of the plates is $6.1 \times 10^{-6} \text{ C/m}^2$ is, calculate the magnitude of the electric field between the plates. (Hint: use a cylindrical Gaussian surface that encloses a part of one of the plates and whose axis is perpendicular to the plate).
- A. $689.894 \times 10^3 \text{ N/C}$
 - B. $965.851 \times 10^3 \text{ N/C}$
 - C. $551.915 \times 10^3 \text{ N/C}$
 - D. $896.862 \times 10^3 \text{ N/C}$
 - E. $620.904 \times 10^3 \text{ N/C}$

3 ELECTRIC POTENTIAL

Properties of conservative forces

Since electric force is conservative, let's start by reviewing some of the properties of conservative forces.

Work done by a conservative force is independent of the path followed. It depends only on the difference between the potential energies (U) (energy due to location, orientation, deformation) at its initial and final locations. This implies that the work done on a closed path is zero because the initial and final locations are the same.

The work done by a conservative force (W_c) is defined to be the negative of the change in the potential energy

$$W_c = -\Delta U$$

Need help with your dissertation?

Get in-depth feedback & advice from experts in your topic area. Find out what you can do to improve the quality of your dissertation!

Get Help Now



Go to www.helpmyassignment.co.uk for more info



If all the forces with non-zero contribution to the work done acting on an object are conservative, then mechanical energy (ME) of the object is conserved. Mechanical energy is the sum of kinetic energy ($KE = \frac{1}{2}mv^2$) and potential energy. The conservation of mechanical energy may be written as

$$\frac{1}{2}mv_i^2 + U_i = \frac{1}{2}mv_f^2 + U_f$$

Or

$$\frac{1}{2}mv_i^2 - \frac{1}{2}mv_f^2 = -(U_f - U_i) = -\Delta U$$

Or

$$\Delta KE = -\Delta U$$

Work Done by Electrical Force

The work done by electrical force (\vec{F}_e) is displacing a charge by an infinitely small displacement $d\vec{r}$ is given by $dW_e = \vec{F}_e \cdot d\vec{r}$. And the work done in displacing the charge from position \vec{r}_i to position \vec{r}_f is obtained by integration.

$$W_e = \int dW_e = \int_{\vec{r}_1}^{\vec{r}_2} \vec{F}_e \cdot d\vec{r}$$

But the electric force can be written in terms of electric field and charge as $\vec{F}_e = q\vec{E}$. Thus, the work done by the electric force may also be written as.

$$W_e = q \int_{\vec{r}_1}^{\vec{r}_2} \vec{E} \cdot d\vec{r}$$

If the electric field is a constant, then it can be taken out of the integral and $W_e = q\vec{E} \cdot \int_{\vec{r}_1}^{\vec{r}_2} d\vec{r}$.

Therefore the work done by a constant electric field may be written as

$$W_e = q\vec{E} \cdot \Delta\vec{r} = qEd \cos(\theta)$$

Where $\Delta\vec{r} = \vec{r}_f - \vec{r}_i$ is the displacement of vector, $d = |\Delta\vec{r}|$ is the magnitude of the displacement and θ is the angle formed between the field and the displacement. If \vec{E} and $\Delta\vec{r}$ have the same direction $\theta = 0$ and

$$W_e = qEd$$

Unit of measurement for work is the Joule (J)

Example: A $6\mu\text{C}$ charge is displaced horizontally by a distance of 2mm in a region where there is an electric field of strength 100 N/C that makes an angle of 60° with the horizontal. Calculate the work done.

Solution:

$$q = 6 \times 10^{-6} \text{ C}; \quad d = 2 \times 10^{-3} \text{ m}; \quad E = 100 \text{ N/C}, \quad \theta = 60^\circ; \quad W_e = ?$$

$$W_e = qEd \cos \theta = (6 \times 10^{-6})(100)(2 \times 10^{-3}) \cos 60^\circ \text{ J} = 2 \times 10^{-9} \text{ J}$$

Example: A $2\mu\text{C}$ charge is displaced from the location $(2\hat{i} - 3\hat{j})$ m to the location $(-4\hat{i} + 9\hat{j})$ m in a region where there is a constant electric field $(-10\hat{i} - 4\hat{j})$ N/C. Calculate the work done by the electric force.

Solution:

$$q = 2 \times 10^{-6} \text{ C}; \quad \vec{r}_i = (2\hat{i} - 3\hat{j}) \text{ m}; \quad \vec{r}_f = (-4\hat{i} + 9\hat{j}) \text{ m}; \quad \vec{E} = (-10\hat{i} - 4\hat{j}) \text{ N/C}; \quad W_e = ?$$

$$\Delta\vec{r} = \vec{r}_f - \vec{r}_i = (-4\hat{i} + 9\hat{j}) \text{ m} - (2\hat{i} - 3\hat{j}) \text{ m} = [-6\hat{i} + 12\hat{j}] \text{ m}$$

$$W_e = q\vec{E} \cdot \Delta\vec{r} = (2 \times 10^{-6}) [(-10\hat{i} - 4\hat{j}) \cdot (-6\hat{i} + 12\hat{j})] \text{ J} = 24 \times 10^{-6} \text{ J}$$

Electrical Potential Energy

The change in the electrical potential energy of charge, q , as it is placed from an initial location \vec{r}_i to a final location \vec{r}_f is equal to the negative of the work done by the electrical force in displacing the charge from the initial location \vec{r}_i to a final location \vec{r}_f .

$$\Delta U = U_f - U_i = -W_e = -q \int_{\vec{r}_i}^{\vec{r}_f} \vec{E} \cdot d\vec{r}$$

Since electric force is a conservative force, this integral does not depend on the path followed between \vec{r}_i and \vec{r}_f . Therefore, it can be evaluated along the straight line joining the initial and the final point. If this line is chosen to be along the x-axis, then $d\vec{r} = dx\hat{i}$ and $\vec{E} \cdot d\vec{r} = E_x dx$ where E_x stands for the x-component of the field; and the integral may be written as

$$\Delta U = -q \int_{x_i}^{x_f} E_x dx$$

If the electric field is a constant, then \vec{E} can be taken out of the integral and $\Delta U = -q\vec{E} \cdot \int_{\vec{r}_1}^{\vec{r}_2} d\vec{r}$

$$\Delta U = -q\vec{E} \cdot \Delta\vec{r} = -qEd \cos \theta$$

And if the electric field and displacement are parallel, then $\theta = 0$ and $\Delta U = -qEd$. If we are interested in the numerical value only, then $|\Delta U| = |q|Ed$.

Example: The electric field along the x-axis varies according to the equation $\vec{E} = 3x\hat{i}$. Calculate the change in the electrical potential energy of a 4 C charge as it is transported from the point $x = 3$ m to the point $x = 10$ m.

Solution:

$$E_x = 3x; x_i = 3 \text{ m}; x_f = 10 \text{ m}; q = 4 \text{ C}; \Delta U = ?$$

$$\Delta U = -q \int_{x_i}^{x_f} E_x dx = -4 \int_3^{10} 3x dx = -546 \text{ J}$$



Brain power

By 2020, wind could provide one-tenth of our planet's electricity needs. Already today, SKF's innovative know-how is crucial to running a large proportion of the world's wind turbines.

Up to 25 % of the generating costs relate to maintenance. These can be reduced dramatically thanks to our systems for on-line condition monitoring and automatic lubrication. We help make it more economical to create cleaner, cheaper energy out of thin air.

By sharing our experience, expertise, and creativity, industries can boost performance beyond expectations. Therefore we need the best employees who can meet this challenge!

The Power of Knowledge Engineering

Plug into The Power of Knowledge Engineering.
Visit us at www.skf.com/knowledge

SKF

Potential Difference

Potential difference between two points (ΔV) is defined to be as the change in potential energy per a unit charge for a charge displaced between the two points.

$$\Delta V = \frac{\Delta U}{q}$$

Unit of measurement for potential difference is J/C which is defined to the Volt (V).

Since $\Delta U = -q \int_{\vec{r}_i}^{\vec{r}_f} \vec{E} \cdot d\vec{r}$, potential difference may also be given in terms of electric field as

$$\Delta V = - \int_{\vec{r}_i}^{\vec{r}_f} \vec{E} \cdot d\vec{r}$$

Where $\Delta V = V(\vec{r}_f) - V(\vec{r}_i)$. Again since this integral is independent of the path followed, it can be evaluated along the straight line joining the two points. If the x-axis is taken to be along the straight line, then

$$\Delta V = - \int_{x_i}^{x_f} E_x dx$$

If the electric field is a constant, \vec{E} can be taken out of the integral and $\Delta V = -\vec{E} \cdot \int_{\vec{r}_i}^{\vec{r}_f} d\vec{r}$. Therefore when the electric field is uniform, the potential difference simplifies to $\Delta V = -\vec{E} \cdot \Delta\vec{r} = -Ed \cos(\theta)$

If the charge is displaced in the direction of the displacement, $\theta = 0$ and $\Delta V = -Ed$. And if only the numerical value is of interest, $|\Delta V| = Ed$.

Example: The electric field in a certain region varies the distance x according to the equation $\vec{E} = \frac{4}{x^2} \hat{i}$. Calculate the potential difference between a point located at $x = 2$ m and a point located at $x = 4$ m

Solution:

$x_i = 2$ m; $x_f = 4$ m; $\Delta V = ?$

$$\Delta V = - \int_{x_i}^{x_f} E_x dx$$

$$\Delta V = - \int_2^4 \frac{4}{x^2} dx = 4 \left(\frac{1}{4} - \frac{1}{2} \right) \text{ V} = -2 \text{ V}$$

The *electron Volt* is a unit of energy commonly used in atomic physics. It is defined to be the amount of energy equal to the change in potential energy of an electron when it is displaced through a potential difference of 1 Volt. Therefore one eV is equal to the product of the charge of an electron and 1 Volt.

$$1\text{eV} = 1.6 \times 10^{-19} \text{ J}$$

Motion of a charge in an electric field

If the only force acting on a charge is electrical force, the net work done is equal to the work done by the electrical force; That is, $W_{\text{net}} = W_e$. According to the work kinetic energy theorem, net work done is equal to the change in kinetic energy of the charged object. Therefore $W_{\text{net}} = W_e = -\Delta U = \Delta KE$. Therefore it follows that

$$\frac{1}{2}mv_f^2 - \frac{1}{2}mv_i^2 = W_e = -\int_{\vec{r}_i}^{\vec{r}_f} \vec{E} \cdot d\vec{r} = -\Delta U = -q\Delta V$$

Where m is the mass of the charge, v_i is the velocity at the initial location and v_f is the velocity at the final location.

Example: Calculate the speed of a proton initially at rest when it is accelerated through a potential difference of 10 Volt.

Solution:

$\Delta V = -10 \text{ V}$ (negative because a proton is displaced in the direction of the field when released from rest)

$q = 1.6 \times 10^{-19} \text{ C}$ (charge of a proton)

$m = 1.67 \times 10^{-27} \text{ kg}$ (mass of a proton)

$v_i = 0$ (released from rest); $v_f = ?$

$$\frac{1}{2}mv_f^2 - \frac{1}{2}mv_i^2 = -q\Delta V$$

$$v_f = \sqrt{\frac{-2q\Delta V}{m}} = \sqrt{\frac{-2(1.6 \times 10^{-19})(-10)}{1.67 \times 10^{-27}}} \text{ m/s} = 4.4 \times 10^4 \text{ m/s}$$

Example: Two oppositely charged parallel plates are separated by a distance of 4 mm. The electric field between the plates is uniform and perpendicular to both plates. Its strength is 20 N/C.

a) Calculate the potential difference between the plates.

Solution:

$$E = 20 \text{ N/C}, \quad d = 4 \times 10^{-3} \text{ m}; \quad \Delta V = ?$$

$$\Delta V = -Ed = -(20)(4 \times 10^{-3}) \text{ V} = 8 \times 10^{-2} \text{ V}$$

b) Calculate the work done by the electric force as a $2 \mu\text{C}$ charge is displaced from the positive plate to the negative plate.

Solution: Since the electric field is directed from the positive to the negative plate, $\theta = 0$

$$q = 2 \times 10^{-6} \text{ C}; \quad W_e = ?$$

$$W_e = qEd = 2 \times 10^{-6} \times 20 \times 0.004 \text{ J} = 1.6 \times 10^{-7} \text{ J}$$

What do you want to do?

No matter what you want out of your future career, an employer with a broad range of operations in a load of countries will always be the ticket. Working within the Volvo Group means more than 100,000 friends and colleagues in more than 185 countries all over the world. We offer graduates great career opportunities – check out the Career section at our web site www.volvogroup.com. We look forward to getting to know you!

VOLVO
AB Volvo (publ)
www.volvogroup.com

VOLVO TRUCKS | RENAULT TRUCKS | MACK TRUCKS | VOLVO BUSES | VOLVO CONSTRUCTION EQUIPMENT | VOLVO PENTA | VOLVO AERO | VOLVO IT
VOLVO FINANCIAL SERVICES | VOLVO 3P | VOLVO POWERTRAIN | VOLVO PARTS | VOLVO TECHNOLOGY | VOLVO LOGISTICS | BUSINESS AREA ASIA

c) Calculate the change in potential energy for a $2 \mu\text{C}$ charge as it is displaced from the positive plate to the negative plate.

Solution:

$$\Delta U = ?$$

$$\Delta U = -W_e = -1.6 \times 10^{-7} \text{ J}$$

e) Calculate the potential difference between the positive and the negative plate ($V_- - V_+$).

Solution:

$$\Delta V = ?$$

$$\Delta V = \frac{\Delta U}{q} = \frac{-1.6 \times 10^{-7}}{2 \times 10^{-6}} \text{ V} = -0.08 \text{ V}$$

f) A proton (mass = $1.67 \times 10^{-27} \text{ kg}$) is released at rest from the positive plate. Calculate its speed by the time it reaches the negative plate.

Solution:

$$v_i = 0; v_f = ?$$

$$\frac{1}{2} m v_f^2 - \frac{1}{2} m v_i^2 = -\Delta U = -q \Delta V$$

$$\frac{1}{2} (1.67 \times 10^{-27} \text{ kg}) v_f^2 = - (1.6 \times 10^{-19}) (-8 \times 10^{-2}) \text{ J}$$

$$v_f^2 = \frac{12.8 \times 10^{-21}}{0.835 \times 10^{-27}} \text{ m}^2/\text{s}^2 = 15.3 \times 10^6 \text{ m}^2/\text{s}^2$$

$$v_f = 1237 \text{ m/s}$$

Potential Due to a Point Charge

Potential difference is independent of the choice of a reference point. But to specify the potential at a given point, a reference point is needed. The value of the potential at a certain point can be fixed arbitrarily; then the potential V at other points is specified with respect to the reference point. For potentials due to point charges, the reference point is taken to be at infinity, and the potential at infinity is set to zero. To obtain the potential at a point a distance r from the charge, first we obtain the potential difference between this point and the point at infinity: $\Delta V = -\int_{\infty}^r \vec{E} \cdot d\vec{r}$. Since this integral is path independent, the integral can be done in a radial direction. Then with $\vec{E} = \frac{kq}{r^2} \vec{e}_r$ and $d\vec{r} = dr \vec{e}_r$ (where $\vec{e}_r = \frac{\vec{r}}{r}$), the integral simplifies to $\Delta V = V(r) - V(\infty) = -\int_{\infty}^r \frac{kq}{r^2} dr$. Setting $V(\infty)$ to zero the following expression for the potential as a function of radial distance is obtained.

$$V(r) = \frac{kq}{r}$$

If with respect to a certain coordinate system, the position vectors of the point where the potential is to be calculated and the charge are \vec{r}_0 and \vec{r}_1 respectively, then $r = |\vec{r}_0 - \vec{r}_1|$ and the potential at the point (V_0) may also be written as

$$V_0 = \frac{kq}{|\vec{r}_0 - \vec{r}_1|}$$

Superposition Principle

If there are a number of point charges in the vicinity of a point, the net potential at the point is obtained by adding the potentials due to the charges algebraically. If the charges q_1, q_2, q_3, \dots located at $\vec{r}_1, \vec{r}_2, \vec{r}_3, \dots$ respectively are in the vicinity of a point located at \vec{r}_0 , then the net potential at the point (V_0) is given by

$$V_0 = k \left(\frac{q_1}{|\vec{r}_0 - \vec{r}_1|} + \frac{q_2}{|\vec{r}_0 - \vec{r}_2|} + \frac{q_3}{|\vec{r}_0 - \vec{r}_3|} + \dots \right) = k \sum_{i=1} \frac{q_i}{|\vec{r}_0 - \vec{r}_i|}$$

Example: Three charged particles of charge -2 nC , 4 nC and -1 nC are located at the points $(0, 0.003)\text{m}$, $(0, 0)\text{m}$, and $(0.004, 0)\text{m}$ respectively. Calculate the net potential at the point $(0.004, 0.003)\text{m}$ due to these charges.

Solution:

$$\vec{r}_0 = (0.004\hat{i} + 0.003\hat{j}) \text{ m}; q_1 = -2 \times 10^{-9} \text{ C}; \vec{r}_1 = 0.003\hat{j} \text{ m}; q_2 = 4 \times 10^{-9} \text{ C}; \vec{r}_2 = 0;$$

$$q_3 = -1 \times 10^{-9} \text{ C}; \vec{r}_3 = 0.004\hat{i} \text{ m}; V_0 = ?$$

$$\vec{r}_0 - \vec{r}_1 = 0.004\hat{i} \text{ m}; \vec{r}_0 - \vec{r}_2 = (0.004\hat{i} + 0.003\hat{j}) \text{ m}; \vec{r}_0 - \vec{r}_3 = 0.003\hat{j} \text{ m}$$

$$|\vec{r}_0 - \vec{r}_1| = 0.004 \text{ m}; |\vec{r}_0 - \vec{r}_2| = \sqrt{0.003^2 + 0.004^2} \text{ m}; |\vec{r}_0 - \vec{r}_3| = 0.003 \text{ m}$$

$$V_0 = k \left(\frac{q_1}{|\vec{r}_0 - \vec{r}_1|} + \frac{q_2}{|\vec{r}_0 - \vec{r}_2|} + \frac{q_3}{|\vec{r}_0 - \vec{r}_3|} \right)$$

$$= 9 \times 10^9 \left(\frac{-2 \times 10^{-9}}{0.004} + \frac{4 \times 10^{-9}}{0.005} + \frac{-1 \times 10^{-9}}{0.003} \right) \text{ V} = -300 \text{ V}$$

gaiteye[®]
Challenge the way we run

**EXPERIENCE THE POWER OF
FULL ENGAGEMENT...**

.....

**RUN FASTER.
RUN LONGER..
RUN EASIER...**

**READ MORE & PRE-ORDER TODAY
WWW.GAITEYE.COM**

Practice Quiz 3.1

Choose the best answer

- Which of the following is a correct statement?
 - The potential at a point due to a point charge is inversely proportional to the square of the distance between the point and the charge.
 - If the only force acting on an object is electrical force, then its mechanical energy is conserved.
 - The unit of measurement for potential difference is the Joule.
 - Electron Volt (eV) is a unit of measurement of potential difference
 - Potential difference between two points is defined to be equal to the change in electrical potential energy of an electron displaced between the two points.
- Two oppositely charged parallel plates are separated by a distance of 0.088 m. If 45 J of work is done by the electric force in displacing a 6 C charge from the positive to the negative plate, calculate the strength of the electric field between the plates.
 - 93.75 N/C
 - 85.227 N/C
 - 51.136 N/C
 - 59.659 N/C
 - 102.273 N/C
- Two oppositely charged parallel plates are separated by a distance of 0.11 m. The strength of the electric field between the plates is 350 N/C. Calculate the change in electric potential energy of a(n) 8 C charge when displaced from the positive to the negative plate by the electric force.
 - 246.4 J
 - 277.2 J
 - 308 J
 - -308 J
 - -277.2 J
- A -0.12 C charge is displaced horizontally to the right with a distance of 0.28 m in a region where there is an electric field of strength 50 directed vertically upward. Calculate the work done by the electric force.
 - 14 J
 - -1.68 J
 - 1.68 J
 - -14 J
 - 0 J

5. A -0.12 C charge is displaced by 0.16 m horizontally to the right in a region where there is an electric field of strength 200 N/C that makes an angle of 30° with the horizontal-right (east). Calculate the work done by the electric force.
- A. -3.326 J
 - B. -3.84 J
 - C. 1.92 J
 - D. -1.92 J
 - E. 3.326 J
6. The potential difference between two oppositely charged parallel plates is 17.1 V . If the strength of the electric field between the plates is 200 N/C , calculate the separation (distance) between the plates.
- A. 0.103 m
 - B. 0.111 m
 - C. 0.086 m
 - D. 0.094 m
 - E. 0.12 m
7. Calculate the work needed to displace a 0.049 C charge through a potential difference of 14 V .
- A. 0.686 J
 - B. 0.823 J
 - C. 0.412 J
 - D. 0.617 J
 - E. 0.48 J
8. Calculate the speed of an object of mass $4e-11\text{ kg}$ and charge $5e-9\text{ C}$ accelerated from rest through a potential difference of 9 V .
- A. 47.434 m/s
 - B. 52.178 m/s
 - C. 33.204 m/s
 - D. 56.921 m/s
 - E. 28.46 m/s

9. Two oppositely charged parallel plates are separated by a distance of 0.1 m. The strength of the electric field between the plates is 250 N/C. An object of mass $1e-10$ kg and charge $9e-9$ C is released from rest at the positive plate. Calculate its speed by the time it reaches the negative plate.
- A. 53.666 m/s
 - B. 67.082 m/s
 - C. 46.957 m/s
 - D. 93.915 m/s
 - E. 60.374 m/s
10. A $-4e-9$ C charge is located on the x-axis at $x = 0.2$ m. A $3e-9$ C charge is located on the x-axis at $x = 0.7$ m. Calculate the net electric potential due to these charges at a point located on the x-axis at $x = 1.2$ m.
- A. 19.111 V
 - B. 13.556 V
 - C. 20.222 V
 - D. 18 V
 - E. 14.667 V

This e-book
is made with
SetaPDF



PDF components for PHP developers

www.setasign.com

11. A $4e-9$ C charge is located at the origin. A $4e-9$ C charge is located on the x-axis at $x = 0.7$ m. Calculate the net electric potential due to these charges at a point located on the y-axis at $y = 1.4$ m.
- A. 45.381 V
B. 50.936 V
C. 53.158 V
D. 48.714 V
E. 49.825 V
12. A $8.2e-9$ C charge is located on the x-axis at $x = 5.4e-3$ m. A $6.1e-9$ C charge is located on the x-axis at $x = 8.3e-3$ m. Calculate the change in potential energy of a 4.5 C charge displaced from the point $x = 15.3e-3$ m to the point $x = 24.6e-3$ m.
- A. 43661.994 J
B. 18192.497 J
C. 25469.496 J
D. 36384.995 J
E. 40023.494 J

Energy Stored by Point Charges

The energy stored (U) by two point charges q_1 and q_2 separated by a distance r_{12} is defined to be the work needed by an external force (W_{ext}) to bring one of the charges (say q_2) from infinity to a separation of distance r from the other charge. Work needed means minimum work without accelerating the charge (that is, $\Delta KE = 0$). The charge is being acted by the external force and the electrical force. Therefore $W_{net} = W_{ext} + W_e = \Delta KE = 0$. Therefore $w_{ext} = -w_e$. But $w_e = -\Delta U = -q_2 \Delta V = -q_2 \left(\frac{kq_1}{r} - 0 \right)$. And since $U = w_{ext} = -w_e = \Delta U$, it follows that the electrical energy stored by the two point charges is given by

$$U = \frac{kq_1 q_2}{r_{12}}$$

The energy is positive when the two charges have the same charge and negative when they have opposite charges. If the position vectors of charges q_1 and q_2 are \vec{r}_1 and \vec{r}_2 respectively, then $r_{12} = |\vec{r}_1 - \vec{r}_2|$ and the energy may alternatively be expressed as

$$U = \frac{kq_1 q_2}{|\vec{r}_1 - \vec{r}_2|}$$

Energy stored by more than two point charges is equal to the external work needed to bring the charges from infinity to their respective positions with respect to one of the charges. For example, if there are 3 charges q_1, q_2 and q_3 , the energy required to bring q_2 from infinity to at a distance of $|\vec{r}_1 - \vec{r}_2|$ from q_1 is $\frac{kq_1q_2}{|\vec{r}_1 - \vec{r}_2|}$. And the energy required to bring q_3 from infinity to a distance of $|\vec{r}_1 - \vec{r}_3|$ from q_1 is given as (remember the third charge is facing electric forces from both q_1 and q_2) $\frac{kq_2q_3}{|\vec{r}_2 - \vec{r}_3|} + \frac{kq_1q_3}{|\vec{r}_1 - \vec{r}_3|}$, where $|\vec{r}_1 - \vec{r}_3|$ and $|\vec{r}_2 - \vec{r}_3|$ are distances of charge 3 from charges 1 and 2 respectively. Therefore the total energy stored by the 3 charges is given as $U = \frac{kq_1q_2}{r_{12}} + \frac{kq_2q_3}{r_{23}} + \frac{kq_1q_3}{r_{13}}$. If there are n charges, by a similar process it can be shown that the energy stored by the n charges is given by

$$U = \frac{k}{2} \sum_{i=1}^n \sum_{j=i+1}^n \frac{q_i q_j}{|\vec{r}_i - \vec{r}_j|}$$

The factor $\frac{1}{2}$ is needed because the summation contributes two of the same terms: $\frac{kq_i q_j}{|\vec{r}_i - \vec{r}_j|}$ and $\frac{kq_j q_i}{|\vec{r}_j - \vec{r}_i|}$.

Example: Particles of charges -2 nC and 4 nC are separated by a distance of 2 mm. Calculate the electrical energy stored by the charges.

Solution:

$$q_1 = -2 \times 10^{-9} \text{ C}; q_2 = 4 \times 10^{-9} \text{ C}; |\vec{r}_1 - \vec{r}_2| = 0.002 \text{ m}; U = ?$$

$$U = \frac{kq_1q_2}{|\vec{r}_1 - \vec{r}_2|} = \frac{(9 \times 10^9)(-2 \times 10^{-9})(4 \times 10^{-9})}{2 \times 10^{-3}} \text{ J} = -3.6 \times 10^{-5} \text{ J}$$

Example: Three particles of charges 3 μC , 4 μC and -5 μC are located at the points (-0.003, 0) m, (0.003, 0) m and (0, 0.004) m respectively. Calculate the electrical energy stored by this system of charges.

Solution:

$$q_1 = 3 \times 10^{-6} \text{ C}; \vec{r}_1 = -0.003\hat{i} \text{ m}; q_2 = 4 \times 10^{-6} \text{ C}; \vec{r}_2 = 0.003\hat{i} \text{ m}; q_3 = -5 \times 10^{-6} \text{ C}; \vec{r}_3 = 0.004\hat{j} \text{ m}; U = ?$$

$$r_{12} = |\vec{r}_1 - \vec{r}_2| = 0.006 \text{ m}; r_{13} = |\vec{r}_1 - \vec{r}_3| = \sqrt{0.003^2 + 0.004^2} = 0.005 \text{ m}; r_{23} = |\vec{r}_2 - \vec{r}_3| = \sqrt{0.003^2 + 0.004^2} = 0.005 \text{ m}$$

$$U = \frac{kq_1q_2}{r_{12}} + \frac{kq_2q_3}{r_{23}} + \frac{kq_1q_3}{r_{13}} = 9 \times 10^{-3} \left(\frac{3 \times 4}{0.006} + \frac{4 \times -5}{0.005} + \frac{3 \times -5}{0.005} \right) \text{ J} = -45 \text{ J}$$

Conservation of Mechanical Energy for a System of Two Point Charges

Mechanical energy of a system of charges is equal to the sum of the electrical potential energy of the system of charges and the kinetic energies of all the charges in the system. If there are 2 charges in the system, the mechanical energy is equal to the sum of the kinetic energies of the two charges and the electric potential energy stored by the charges.

$$ME = \frac{1}{2} m_1 v_1^2 + \frac{1}{2} m_2 v_2^2 + \frac{kq_1q_2}{r_{12}}$$

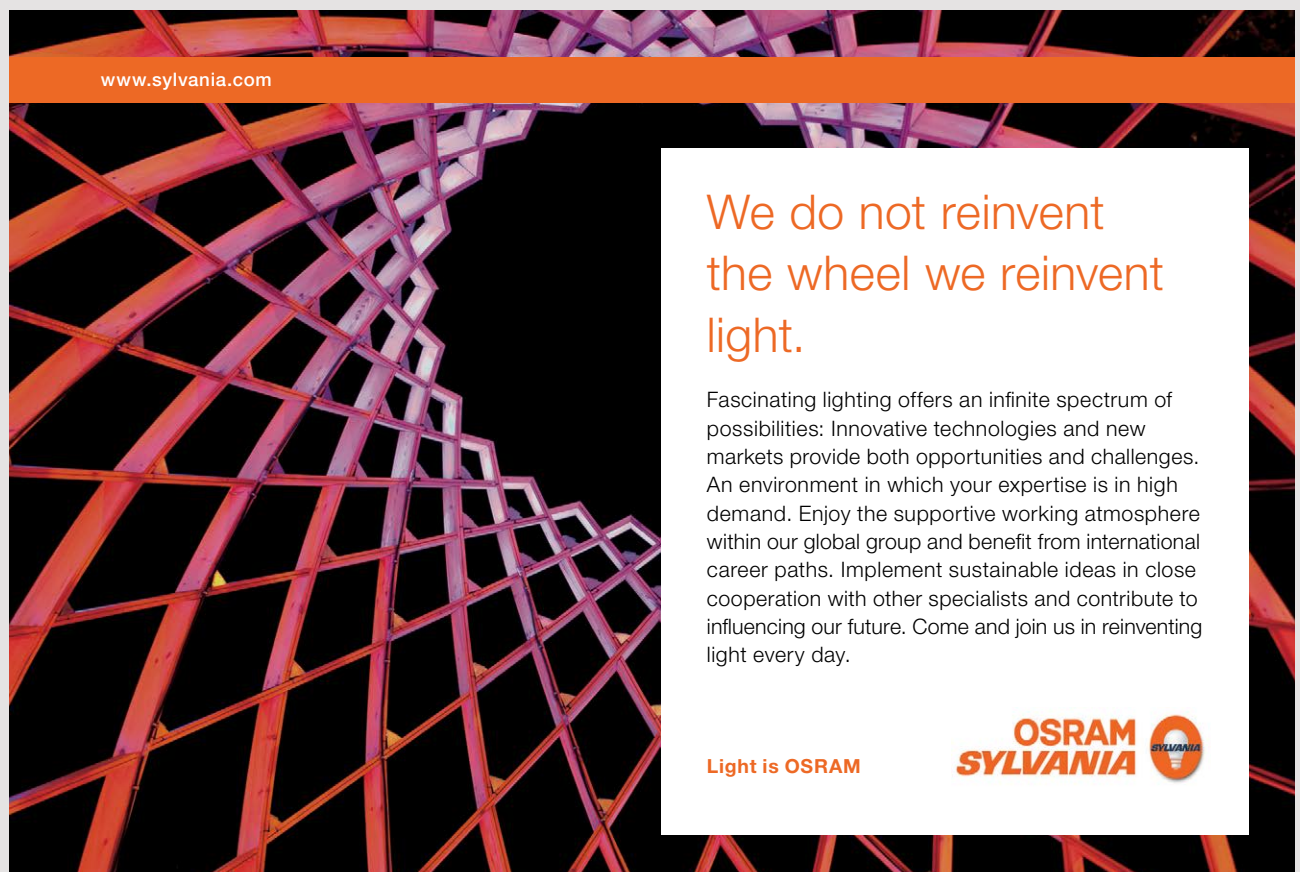

www.sylvania.com

We do not reinvent
the wheel we reinvent
light.

Fascinating lighting offers an infinite spectrum of possibilities: Innovative technologies and new markets provide both opportunities and challenges. An environment in which your expertise is in high demand. Enjoy the supportive working atmosphere within our global group and benefit from international career paths. Implement sustainable ideas in close cooperation with other specialists and contribute to influencing our future. Come and join us in reinventing light every day.

Light is OSRAM

OSRAM
SYLVANIA

Therefore the principle of conservation of mechanical energy for a system of two charges can be written as

$$\frac{1}{2}m_1v_{1i}^2 + \frac{1}{2}m_2v_{2i}^2 + \frac{kq_1q_2}{r_{12i}} = \frac{1}{2}m_1v_{1f}^2 + \frac{1}{2}m_2v_{2f}^2 + \frac{kq_1q_2}{r_{12f}}$$

Example: A proton is fixed at a certain location. Another proton is propelled towards this proton with a speed of 2×10^3 m/s from a very large distance effectively infinity. How close would the two protons get.

Solution:

$$v_{1i} = v_{1f} = 0; v_{2i} = 2 \times 10^3 \text{ m/s}; r_{1i} = \infty; m_1 = m_2 = 1.67 \times 10^{-27} \text{ kg};$$

$$v_{2f} = 0 \text{ (at the closest distance (turning point) speed should be zero)}; r_{1f} = ?$$

$$\cancel{\frac{1}{2}m_1v_{1i}^2} + \frac{1}{2}m_2v_{2i}^2 + \cancel{\frac{kq_1q_2}{r_{12i}}} = \cancel{\frac{1}{2}m_1v_{1f}^2} + \frac{1}{2}m_2v_{2f}^2 + \frac{kq_1q_2}{r_{12f}}$$

$$\frac{1}{2}m_2v_{2i}^2 = \frac{kq_1q_2}{r_{12f}}$$

$$r_{12f} = \frac{2kq_1q_2}{m_2v_{2i}^2} = \frac{2(9 \times 10^9)(1.6 \times 10^{-19})^2}{(1.67 \times 10^{-27})(2 \times 10^3)^2} \text{ m} = \underline{6.9 \times 10^{-8} \text{ m}}$$

Example: Two protons separated by a distance of 0.002 m are initially at rest. If they are released at the same time, calculate their speeds after the distance between them is doubled.

Solution:

Since the two protons are subjected to the same force (action reaction forces), they will have the same speed at any point.

$$r_{12i} = 0.002 \text{ m}; r_{12f} = 2(r_{1i}) = 0.004 \text{ m}; m_1 = m_2 = m_p = 1.67 \times 10^{-27} \text{ kg (mass of a proton)}$$

$$q_1 = q_2 = q_p = 1.6 \times 10^{-19} \text{ C (charge of a proton)}$$

$$v_{1i} = v_{2i} = 0; v_{1f} = v_{2f} = v = ?$$

$$\cancel{\frac{1}{2}m_1v_{1i}^2} + \cancel{\frac{1}{2}m_2v_{2i}^2} + \frac{kq_1q_2}{r_{12i}} = \frac{1}{2}m_1v_{1f}^2 + \frac{1}{2}m_2v_{2f}^2 + \frac{kq_1q_2}{r_{12f}}$$

$$\frac{1}{2} m_2 v_{2i}^2 = \frac{k q_1 q_2}{r_{12f}}$$

$$v = \sqrt{\frac{k q_p^2 \left(\frac{1}{r_{12i}} - \frac{1}{r_{12f}} \right)}{m_p}} = \sqrt{\frac{9 \times 10^9 [1.6 \times 10^{-19}]^2}{1.67 \times 10^{-27}} \left(\frac{1}{0.002} - \frac{1}{0.004} \right)} \text{ m/s} = \underline{5.87 \text{ m/s}}$$

Potential due to a Continuous Distribution of Charges

Potential at a certain point P (V_p) due to a continuous distribution of charges is obtained first by dividing the charges into small charges dq ; and then obtaining the potential due to an arbitrary charge dq . If the distance between dq and point P is r_p , then the potential at point P due to dq is $k \frac{dq}{r_p}$. The net potential is obtained by integrating over the total charge. To convert the integral over charge to an integral over volume, dq can be expressed in terms of small volume element (dV) and the charge density ρ as $dq = \rho dV$.

$$V_p = k \int \frac{dq}{r_p} = k \int \frac{\rho dV}{r_p}$$

If \vec{r} and \vec{r}' are the position vectors of point P and dq with respect to a certain coordinate system respectively, then $r_p = |\vec{r} - \vec{r}'|$. And replacing dV by dV' (to emphasize that the integral is over \vec{r}' and not over \vec{r}), the potential at point P, can also be written as

$$V_p = k \int \frac{\rho dV'}{|\vec{r} - \vec{r}'|}$$

For linear charge density, the symbol λ is used customarily and $dq = \lambda dx$ where dx is a small path element.

$$V_p = k \int \frac{\lambda dx'}{|x - x'|}$$

For areal charge density, the symbol σ is used customarily and $dq = \sigma dA$ where dA is a small area element.

$$V_p = k \int \frac{\sigma dA'}{|\vec{r} - \vec{r}'|}$$

Example: A rod of length L and charge density λ lies along the x-axis. Its left end is at the origin. Obtain an expression for the potential at a point P on the x-axis that is located a distance a to the right of the right end of the rod.

Solution: Let dx be an arbitrary small path element with charge dq located a distance x from the origin. Then the distance between dq and point P (r_p) is $(a + L - x)$ (Or alternatively,

$\vec{r} = (a+L)\hat{i}$; $\vec{r}' = x\hat{i}$ and $r_p = |\vec{r} - \vec{r}'| = a+L-x$. Also $dq = \lambda dx$. Therefore the potential at point

P can be written as $V_p = \int_{x=0}^{x=L} \frac{k\lambda dx}{a+L-x}$. Let, $u = L+a-x$, then $du = -dx$, $u(x=0) = L+a$

and $u(x=L) = a$. Then $V_p = -k\lambda \int_{L+a}^a \frac{du}{u} = -k\lambda(\ln(a) - \ln(L+a)) = k\lambda \ln\left(\frac{L+a}{a}\right)$.

Example: Consider a uniformly charged ring of radius R and total charge Q on the yz -plane centered at the origin. Obtain an expression for the potential at a point P located on the x -axis at a distance x from the origin.



Discover the truth at www.deloitte.ca/careers

Deloitte.

© Deloitte & Touche LLP and affiliated entities.

Solution: Let ds be an arbitrary small arc-length element where charge dq is contained. Then $dq = \lambda ds$. Since it is uniformly charged, the linear charge density can be obtained by dividing the total charge by the circumference of the ring. Thus, $dq = \frac{Q}{2\pi R} ds$. The distance between ds and point P is $\sqrt{R^2 + x^2}$. The potential at point P due to the charge dq is given as $dV_P = k \frac{Q}{2\pi R} \frac{ds}{\sqrt{R^2 + x^2}}$ and the net potential is obtained by integrating s from 0 to $2\pi R$ (circumference): $V_P = k \frac{Q}{2\pi R \sqrt{R^2 + x^2}} \int_0^{2\pi R} ds = \frac{kQ}{\sqrt{R^2 + x^2}}$.

Example: Consider a uniformly charged disc of radius R and total charge Q on the yz -plane centered at the origin. Obtain an expression for the potential at a point P on the x -axis a distance x from the origin.

Solution: Consider a ring of radius $r < R$ and thickness dr centered at the origin. As shown in the previous problem, the potential at point P due to this ring is $\frac{k dq}{\sqrt{r^2 + x^2}}$ where dq stands for the charge contained on the ring. Since it is uniformly charged, the charge density is equal to the ratio of total charge to the area of the disc $\left(\frac{Q}{\pi R^2}\right)$. Therefore $dq = \frac{Q}{\pi R^2} 2\pi r dr$ where $2\pi r dr$ is the area of the ring. Now the potential due to the ring may be written as $dV_P = \frac{2kQ}{R^2} \frac{r dr}{\sqrt{r^2 + x^2}}$ and the total potential is obtained by integrating this from 0 to R :
 $V_P = \frac{2kQ}{R^2} \int_0^R \frac{r dr}{\sqrt{r^2 + x^2}}$. Let $x^2 + r^2 = u$ then $du = 2r dr$, $u(r=0) = x^2$ and $u(r=R) = x^2 + R^2$. Then
 $V_P = \frac{kQ}{R^2} \int_{x^2}^{x^2+R^2} \frac{d(u)}{\sqrt{u}} = \frac{2kQ}{R^2} (\sqrt{x^2 + R^2} - x)$.

Obtaining Potential from Electric Field

First select a reference point. Then obtain an expression for the potential difference between an arbitrary point and the reference point and then set the potential at the reference point to zero.

Example: The electric field in a certain region varies along the x -axis according to the equation $\vec{E} = 2x\hat{i}$. Find an expression for the potential at an arbitrary point with respect to the origin.

Solution

$$V(0) = 0; \vec{E} = 2x\hat{i}; V(x) = ?$$

$$V(x) - V(0) = V(x) = -\int_0^x \vec{E} \cdot d\vec{r} \quad \text{But } \vec{E} \cdot d\vec{r} = (2x\hat{i}) \cdot (dx\hat{i}) = 2x dx$$

$$\therefore V(x) = -\int_0^x 2x dx = \underline{-x^2}$$

Example: The electric field due to a uniformly charged solid sphere of radius R and total charge Q is given by

$$E = \begin{cases} \frac{kQr}{R^3} & \text{for } r < R \\ \frac{kQ}{r^2} & \text{for } r > R \end{cases}$$

Obtain an expression for the potential as a function of r by assuming the potential at infinity to be zero.

Solution:

For $r < R$

Since electrical force is conservative any path can be used to the integral. Let's use a radial direction. Then $\vec{E} = \frac{kQ}{r^2} \hat{e}_r$, $d\vec{r} = dr \hat{e}_r$ and $\vec{E} \cdot d\vec{r} = E dr$. Therefore $\Delta V = V(r) - V(\infty) = -\int_{\infty}^r \frac{kQ}{r^2} dr = \frac{kQ}{r}$

Since $V(\infty)$ is assumed to be zero, $V(r) = \frac{kQ}{r}$ for $r < R$.

For $r > R$

$$V(r) - V(\infty) = -\int_{\infty}^r \vec{E} \cdot d\vec{r} = -\int_{\infty}^R \vec{E} \cdot d\vec{r} - \int_R^r \vec{E} \cdot d\vec{r} = V(R) - V(\infty) - \int_R^r \vec{E} \cdot d\vec{r}. \quad \text{Therefore } V(R) - V(r) = -\int_R^r E \cdot dr.$$

But for $r < R$, $E = \frac{kQr}{R^3}$ and $V(R) - V(r) = -\frac{kQ}{R^3} \int_R^r r dr = -\frac{1}{2} \frac{kQ}{R^3} (R^2 - r^2)$. But from the result for

$$r \geq R, \quad V(R) = \frac{kQ}{R} \quad \text{and} \quad V(r) = \frac{1}{2} \frac{kQ}{R} \left(3 - \frac{r^2}{R^2} \right).$$

Obtaining Electric field from Potential

$\Delta V = \int dV = - \int \vec{E} \cdot d\vec{r}$ which implies $dV = -\vec{E} \cdot d\vec{r}$. For simplicity, let's consider straight line displacements (say along x -axis) then $\vec{E} \cdot d\vec{r} = E_x dx$ and $dV = -E_x dx$. It follows that electric field can be obtained as the negative derivative of potential with respect to position.

$$E_x = -\frac{dV}{dx}$$

Example: The potential due to a certain charge varies with position according to the equation $V = 3\cos(x) + 1$. Obtain an expression for the electric field as a function of position.

Solution:

$$\begin{aligned} E(x) &= -\frac{dV}{dx} \\ &= -\frac{d}{dx}[3\cos(x) + 1] \\ &= 3\sin x \end{aligned}$$

SIMPLY CLEVER

ŠKODA



We will turn your CV into
an opportunity of a lifetime



Do you like cars? Would you like to be a part of a successful brand?
We will appreciate and reward both your enthusiasm and talent.
Send us your CV. You will be surprised where it can take you.

Send us your CV on
www.employerforlife.com



Potential of a conductor in Electrostatic equilibrium

A conductor in electrostatic equilibrium is a conductor where the charges are not moving. This implies the electric field inside is zero (because if there was, the charges would be moving). This also implies all the points in a conductor in electrostatic equilibrium are at the same potential. Because if points A and B are inside the conductor then $\Delta V = V(B) - V(A) = -\int_A^B \vec{E} \cdot d\vec{r} = 0$ (because $\vec{E} = 0$) which implies that all points inside a conductor are at the same potential. Also no work is required to transport a charge from one point to another point inside a conductor in electrostatic equilibrium; because $w_e = -\Delta U = -q\Delta V = 0$ (because $\Delta V = 0$).

As noted in the previous chapter, excess charges of a conductor in electrostatic equilibrium must reside on the surface of the conductor. (If there were excess charges inside, from Gauss's law it will follow that there is a non-zero electric field inside).

The electric field just outside a spherical charged sphere is $\frac{kQ}{R^2}$ as shown previously. That is the electric field decreases as $\frac{1}{R^2}$ at the surface. Therefore the smaller the radius of curvature the greater the electric field at the surface. This indicates that for surfaces of irregular shape the electric field just outside the conductor is greater for sharp surface than for dull surfaces. Also since the electric field just outside a conductor in electrostatic equilibrium ($E = 4\pi k\sigma$) is proportional to the charge density, it follows that the charge density is greater at sharp surfaces than it is at dull surfaces.

Equipotential surfaces are surfaces that contain points at the same potential only. The work done in taking a charge from one point of an equipotential surface to another point of the equipotential surface is zero because $\Delta V = 0$ ($\Delta V = 0$ because all the points are at the same potential). That is, $w_e = -q\Delta V = 0$.

But the work done is also equal to $qEds \cos(\theta)$ (where θ is the angle between the path element on the equipotential surface and the field). This can be zero only if the angle is zero. It follows that equipotential surfaces and electric fields are perpendicular to each other everywhere. For example, if the equipotential surfaces are spherical, the electric field lines must be radial.

Practice Quiz 3.2

Choose the best answer

- Which of the following is a correct statement?
 - A non-zero work is required to transport a charge from one point to another point of a conductor in electrostatic equilibrium.
 - No work is required to transport a charge from one point to another point of a conductor in electrostatic equilibrium.
 - The electric field just outside a conductor in electrostatic equilibrium is parallel to the surface.
 - The potential inside a conductor in electrostatic equilibrium may vary from point to point.
 - Electric field lines and equipotential surfaces are parallel to each other.
- Calculate the electrical energy stored between a $-8e-6$ C charge and a $-6e-6$ C charge separated by a distance of 0.01 m.
 - 34.56 J
 - -47.52 J
 - 47.52 J
 - -43.2 J
 - 43.2 J
- The charges $3.2e-6$ C, $6.3e-6$ C and $-9.1e-6$ C are located at the points $x = -1.6e-3$ m, $x = 0$, and at $x = 0.015$ m. Calculate the electric potential energy stored by these system of charges.
 - 75.857 J
 - 82.178 J
 - 56.893 J
 - 63.214 J
 - 37.928 J
- Two protons are separated by a distance of $8.3e-9$ m. One of the protons is released from rest. Calculate its speed by the time their separation has increased to $8.3e-8$ m. (The charge and mass of a proton are $1.6e-19$ C and $1.67e-27$ kg respectively.)
 - $7.111e3$ m/s
 - $4.376e3$ m/s
 - $6.017e3$ m/s
 - $7.658e3$ m/s
 - $5.47e3$ m/s

5. Consider a uniformly charged rod of charge density $3.7e-9 \text{ C/m}$ that extends from the origin to $x = 0.2 \text{ m}$. Calculate the electric potential due to this rod at the point $x = 1.2 \text{ m}$.
- A. 4.25 V
 - B. 5.464 V
 - C. 7.286 V
 - D. 6.071 V
 - E. 8.5 V
6. The charge density of a disc of radius 0.2 m varies on distance from the center of the disc according to the equation $\sigma(r) = 1.1e-9r$. Calculate the electric potential at the center of the disc.
- A. 0.746 V
 - B. 1.617 V
 - C. 1.493 V
 - D. 1.244 V
 - E. 1.368 V

I joined MITAS because
I wanted **real responsibility**

The Graduate Programme
for Engineers and Geoscientists
www.discovermitas.com



Month 16

I was a construction
supervisor in
the North Sea
advising and
helping foremen
solve problems

Real work
International opportunities
Three work placements



 **MAERSK**

7. The electric field in a certain region varies according to the equation $E(x) = (1.8/x^4 + 1/x^2) \mathbf{i}$. Calculate the potential at the point $x = 1.8$ m with respect to the potential at infinity.
- A. -0.922 V
 - B. -0.461 V
 - C. -0.79 V
 - D. -0.658 V
 - E. -0.593 V
8. Calculate the potential (with respect to infinity) at a point which is located at a distance of 6.1 m from the center of a uniformly charged sphere of radius 0.5 m and a charge density of $8.4e-9$ C/m³.
- A. $9084.868e-3$ V
 - B. $7138.111e-3$ V
 - C. $5191.353e-3$ V
 - D. $6489.191e-3$ V
 - E. $4542.434e-3$ V
9. The potential in a certain region varies according to the equation $V(x) = 2.4x + 0.1 \sin(1.6x)$. Calculate the electric force exerted on a 1.5 C charge located at the point $x = 1.6$ m.
- A. -2.38 N/C \mathbf{i}
 - B. -4.079 N/C \mathbf{i}
 - C. -3.06 N/C \mathbf{i}
 - D. -3.399 N/C \mathbf{i}
 - E. -2.04 N/C \mathbf{i}
10. The electric potential due to a certain distribution of charges varies with x according to the equation $V(x) = 1.2/x - 1.1/x^2$. Any charge will experience no electrical force if it is located at $x =$
- A. 2.383 m
 - B. 1.833 m
 - C. 2.2 m
 - D. 2.567 m
 - E. 2.2 m

4 CAPACITANCE AND DIELECTRIC

Your goal for this chapter is to understand the properties of capacitors and combinations of capacitors.

A Capacitor is two conductors (*or more*) separated by an insulator. A capacitor is used to store charges or electrical energy. The circuit symbol of a capacitor is



Figure 7.1

When a capacitor is connected to a potential difference (such as a battery), charges are transferred from one of the conductors to the other conductor, and both conductors acquire equal but opposite charge. The charge accumulated is directly proportional to the potential difference between the conductors. That is $Q/\Delta V = \text{constant}$ where Q is charge accumulated by the conductors and ΔV is the potential difference between the conductors. The constant of proportionality is called the capacitance of the capacitor and denoted by C .

$$Q = C\Delta V$$

The unit of measurement for capacitance is coulomb/volt which is defined to be the Farad abbreviated as F.

Some Types of Capacitors

Parallel Plate Capacitor

A parallel plate capacitor is two parallel plates separated by an insulator. Let the area, separation and charge density of the capacitor be denoted by A , d and σ respectively. From symmetry, the electric field is uniform and perpendicular to the plate inside (between) the plates and approximately zero outside the plates. An expression for the electric field can be obtained by using Gauss's law. Let the Gaussian surface be a small cylindrical surface of base area dA enclosing a part of one of the plates whose axis is perpendicular to the plate.

The electric flux crossing part of the cylinder outside the plates is zero because the electric field outside the plates is approximately zero. The electric flux on the curved surface inside plates is zero because the area vector and the electric field perpendicular to each other. The only contribution to the electric flux comes from the end face inside the plates. The charge enclosed by the Gaussian surface is σdA and using Gauss's law $E dA = 4\pi k \sigma dA$. Therefore the magnitude of the electric field between the plates is given by

$$E = 4\pi k \sigma = \frac{\sigma}{\epsilon_0}$$

Now that we have an expression for the electric field inside, we can also obtain an expression for the potential difference between the plates. Since the electric field is a constant, $|\Delta V| = Ed = \frac{\sigma d}{\epsilon_0}$. The capacitance of the capacitor is the ratio between the charge ($Q = \sigma A$) and the potential difference. Therefore the capacitance (C_p) of a parallel plate capacitor of area A and separation d is given by

$$C_p = \frac{\epsilon_0 A}{d}$$

ie business school

#1 EUROPEAN BUSINESS SCHOOL
FINANCIAL TIMES 2013

#gobeyond

MASTER IN MANAGEMENT

Because achieving your dreams is your greatest challenge. IE Business School's Master in Management taught in English, Spanish or bilingually, trains young high performance professionals at the beginning of their career through an innovative and stimulating program that will help them reach their full potential.

- Choose your area of specialization.
- Customize your master through the different options offered.
- Global Immersion Weeks in locations such as London, Silicon Valley or Shanghai.

Because you change, we change with you.

www.ie.edu/master-management | mim.admissions@ie.edu | [f](#) [t](#) [in](#) [YouTube](#) [i](#)

Example: The plates of a parallel plate capacitor have an area of 2 cm^2 and are separated by a distance of 0.5 cm . Each has a charge of 0.005 nC .

a) Calculate the capacitance of the capacitor.

Solution:

$$A = 2 \times 10^{-4} \text{ m}^2; d = 5 \times 10^{-3} \text{ m}; C_p = ?$$

$$C_p = \frac{\epsilon_0 A}{d} = \frac{(8.85 \times 10^{-12}) (2 \times 10^{-4})}{5 \times 10^{-3}} \text{ F} = 3.54 \times 10^{-13} \text{ F}$$

b) Calculate the potential difference between the plates.

Solution:

$$Q = 5 \times 10^{-12} \text{ C}$$

$$\Delta V = \frac{Q}{C_p} = \frac{5 \times 10^{-12}}{3.54 \times 10^{-13}} \text{ V} = 14.1 \text{ V}$$

c) Calculate the strength of the electric field between the plates.

Solution:

Calculate the capacitance of the capacitor.

$$\text{Given: } A = 2 \text{ cm}^2 = 2 \times 10^{-4} \text{ m}^2; d = 5 \times 10^{-3} \text{ m}$$

$$C_p = \frac{\epsilon_0 A}{d} = \frac{(8.85 \times 10^{-12}) (2 \times 10^{-4})}{5 \times 10^{-3}} \text{ F} = 3.54 \times 10^{-13} \text{ F}$$

Concentric Cylindrical Capacitor

Concentric Cylindrical Capacitor is a capacitor made up of two concentric cylinders. Consider two concentric cylinders of radii a and b . Let the linear charge density of the cylinders be $\lambda = \frac{Q}{L}$ where Q is the total charge and L is the length of the cylinders.

If the cylinders are long enough, it can be shown from Gauss's law that the electric field between the cylinders is given by $\vec{E} = \frac{2k\lambda}{r_{\perp}} \vec{e}_{r_{\perp}}$ (here r_{\perp} is the perpendicular distance between a point and the axis of the cylinders and $\vec{e}_{r_{\perp}} = \frac{\vec{r}}{r_{\perp}}$ is a unit vector perpendicular to the axis of the cylinders). The potential difference between the two cylinders is given by $\Delta V = -\int \vec{E} \cdot d\vec{r}$. With $d\vec{r} = dr_{\perp} \vec{e}_{r_{\perp}}$, $\vec{E} \cdot d\vec{r} = \frac{2k\lambda}{r_{\perp}} dr_{\perp}$ and $\Delta V = -\int_a^b \frac{2k\lambda}{r_{\perp}} dr_{\perp} = -2k\lambda \ln \frac{b}{a}$. The capacitance of the concentric cylinders is obtained as the ratio between the total charge and the potential difference: $C = \frac{Q}{|\Delta V|} = \frac{Q}{2k\lambda \ln \frac{b}{a}}$ and with $\lambda = \frac{Q}{L}$, the capacitance of a cylindrical capacitor is given by

$$C = \frac{L}{2k \ln\left(\frac{b}{a}\right)}$$

Concentric Spherical Capacitor

Concentric Spherical Capacitor is a capacitor formed by two concentric spheres. Consider two concentric spherical surfaces of radii a and b (with $a < b$). Let the total charge of the capacitor be Q .

From Gauss's law, it can be shown that the electric field between the spherical surfaces is given by

$$E = \frac{KQ}{r^2} \vec{e}_r \quad \text{where} \quad \vec{e}_r = \frac{\vec{r}}{r} \quad \text{and} \quad \vec{r} \text{ is a position vector with respect to the center of the spheres.}$$

\vec{r} stands for the position vector with respect to the center of the sphere. With $d\vec{r} = dr \vec{e}_r$, $\Delta V = -\int \vec{E} \cdot d\vec{r} = -\int_{r=a}^{r=b} \frac{kQ}{r^2} dr = -kQ \left(\frac{b-a}{ab} \right)$. Therefore, the capacitance of a spherical capacitor $\left(\frac{Q}{|\Delta V|} \right)$ is given as

$$C = \frac{ab}{k(b-a)}$$

Parallel Combination of Capacitors

Capacitors are said to be connected in parallel if they are connected in a branched connection as shown.

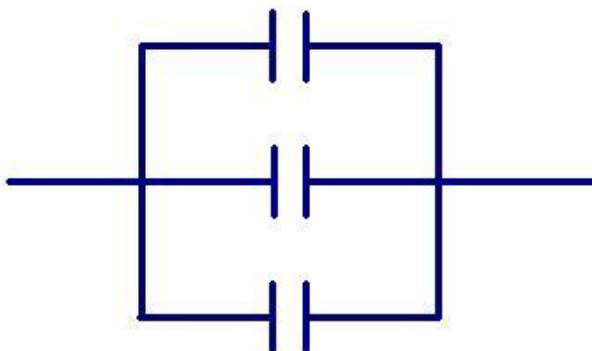
**Figure 7.2**

Capacitors connected in parallel have the same potential difference because the conductors on the same side are connected by conductors (electric wires) and are at the same potential; but the charge will be divided among the capacitors according to their capacitances. So the total charge is equal to the sum of the charges of each capacitor. If capacitors C_1 , C_2 , C_3 , ... are connected in parallel and then connected to a potential difference ΔV , then

$$\Delta V = \Delta V_1 = \Delta V_2 = \Delta V_3 = \dots$$

$$Q = Q_1 + Q_2 + Q_3 + \dots$$

"I studied English for 16 years but...
...I finally learned to speak it in just six lessons"
Jane, Chinese architect

ENGLISH OUT THERE

Click to hear me talking before and after my unique course download

Where Q is the total charge.

Equivalent Capacitance

The equivalent capacitance of a group of capacitors is defined to be the ratio between the total charge (Q) and the total potential difference (ΔV)

$$C_{eq} = \frac{Q}{\Delta V}$$

For parallel combination, $Q = Q_1 + Q_2 + Q_3 + \dots$. But $Q = C_{eq} \Delta V$, $Q_1 = C_1 \Delta V$, $Q_2 = C_2 \Delta V$, $Q_3 = C_3 \Delta V, \dots$. Therefore for a parallel combination of capacitors, the equivalent capacitance is equal to the sum of the capacitances of the capacitors.

$$C_{eq} = C_1 + C_2 + C_3 + \dots$$

Example: A $2F$, a $4F$ and a $6F$ capacitor are connected in parallel and then connected to a potential difference of $12V$.

a) Calculate the potential difference across each capacitor.

Solution:

$$\Delta V = 12 \text{ V}; \Delta V_1 = ?; \Delta V_2 = ?; \Delta V_3 = ?$$

$$\Delta V_1 = \Delta V_2 = \Delta V_3 = \Delta V = 12 \text{ V}$$

b) Calculate the charge stored by each capacitor.

Solution:

$$C_1 = 2 \text{ F}; C_2 = 4 \text{ F}; C_3 = 6 \text{ F}; Q_1 = ?; Q_2 = ?; Q_3 = ?$$

$$Q_1 = C_1 \Delta V_1 = 2(12) \text{ C} = 24 \text{ C}$$

$$Q_2 = C_2 \Delta V_2 = 4(12) \text{ C} = 48 \text{ C}$$

$$Q_3 = C_3 \Delta V_3 = 6(12) \text{ C} = 72 \text{ C}$$

c) Calculate the total charge stored by the capacitors.

Solution:

$$Q = Q_1 + Q_2 + Q_3 = (24 + 48 + 72) \text{ C} = 144 \text{ C}$$

d) Calculate the equivalent capacitance of the capacitors.

Solution:

$$C_{eq} = C_1 + C_2 + C_3 = (2 + 4 + 6) \text{ F} = 12 \text{ F}$$

Or

$$C_{eq} = \frac{Q}{\Delta V} = \frac{144}{12} \text{ F} = 12 \text{ F}$$

Series Combination of Capacitors

Capacitors are said to be connected in series when they are connected in one line.



Figure 7.3

When capacitors in series are connected to a potential difference, electrons are taken from one of the outermost conductors and taken to the outermost conductor on the other side. All the conductors in between are charged by induction. Thus, in a series combination all of the capacitor will acquire the same charge which is also equal to the total charge acquired by the capacitors. The total potential difference across the combination will be divided into the capacitors according to their capacitance.

If capacitors C_1, C_2, C_3, \dots are connected in series and then connected to a potential difference ΔV , then

$$Q = Q_1 = Q_2 = Q_3 = \dots$$

$$\Delta V = \Delta V_1 + \Delta V_2 + \Delta V_3 + \dots$$

Where Q is the total charge. The equivalent capacitance of the combination is defined to be the ratio between the total charge and the total potential difference

$$\left(C_{eq} = \frac{Q}{\Delta V} \right) \cdot \Delta V = \frac{Q}{C_{eq}}, \Delta V_1 = \frac{Q_1}{C_1} = \frac{Q}{C_1}, \Delta V_2 = \frac{Q}{C_2}, \dots \text{ Therefore } \Delta V = \Delta V_1 + \Delta V_2 + \Delta V_3 + \dots \text{ implies}$$

$$\frac{Q}{C_{eq}} = \frac{Q}{C_1} + \frac{Q}{C_2} + \frac{Q}{C_3} + \dots \text{ or } \frac{1}{C_{eq}} = \frac{1}{C_1} + \frac{1}{C_2} + \frac{1}{C_3} + \dots \text{ Thus the equivalent capacitance of capacitors}$$

in series is given by

$$C_{eq} = \left(\frac{1}{C_1} + \frac{1}{C_2} + \frac{1}{C_3} + \dots \right)^{-1}$$

Example: A $2F$, a $4F$ and a $6F$ capacitor are connected in series and then connected to a potential difference of $12V$.

Excellent Economics and Business programmes at:



university of
 groningen



“The perfect start
of a successful,
international career.”

CLICK HERE
to discover why both socially
and academically the University
of Groningen is one of the best
places for a student to be

www.rug.nl/feb/education

a) Calculate the equivalent capacitance of the capacitors.

Solution:

$$C_1 = 2 \text{ F}; C_2 = 2 \text{ F}; C_3 = 2 \text{ F}; C_{eq} = ?$$

$$C_{eq} = \left(\frac{1}{C_1} + \frac{1}{C_2} + \frac{1}{C_3} \right)^{-1} = \frac{12}{11} \text{ F}$$

b) Calculate the total charge accumulated by the capacitors.

Solution:

$$\Delta V = 12 \text{ V}; Q = ?$$

$$Q = C_{eq} \Delta V = \frac{12}{11} (12) \text{ F} = \frac{144}{11} \text{ F}$$

c) Calculate the charge accumulated by each capacitor.

Solution:

$$Q_1 = Q_2 = Q_3 = Q = \frac{144}{11} \text{ C}$$

d) Calculate the charge accumulated by each capacitor.

Solution:

$$\Delta V_1 = \frac{Q_1}{C_1} = \frac{Q}{C_1} = \frac{144}{11 \cdot 2} \text{ V} = \frac{72}{11} \text{ V}$$

$$\Delta V_2 = \frac{Q_2}{C_2} = \frac{Q}{C_2} = \frac{144}{11 \cdot 4} \text{ V} = \frac{36}{11} \text{ V}$$

$$\Delta V_2 = \frac{Q_2}{C_2} = \frac{Q}{C_2} = \frac{144}{11 \cdot 4} \text{ V} = \frac{36}{11} \text{ V}$$

Practice Quiz 4.1

Choose the best answer

- Which of the following is a correct statement?
 - The capacitance of a parallel plate capacitor is directly proportional to the separation between the plates.
 - The charge stored in a capacitor is inversely proportional to the potential difference across the capacitor.
 - The capacitance of a parallel plate capacitor is directly proportional to the area of the plates.
 - A capacitor is a device that converts electrical energy to non-electrical energy.
 - The SI unit of measurement for capacitance is the Ohm.
- Which of the following is a correct statement?
 - The potential differences across capacitors connected in series are equal.
 - The total charge accumulated by capacitors in series is equal to the sum of the charges in each capacitor.
 - The total potential difference across capacitors connected in parallel is equal to the sum of the potential differences across each capacitor.
 - The potential differences across capacitors connected in parallel are equal.
 - The charges stored by capacitors in parallel are equal.
- Calculate the charge accumulated by a $2.1e-6$ F connected to a 1 V battery.
 - $2.1e-6$ C
 - $1.26e-6$ C
 - $1.89e-6$ C
 - $1.68e-6$ C
 - $1.47e-6$ C
- Calculate the potential difference of a parallel plate capacitor made up of two circular conductors of radius $9.1e-2$ m and separated by a distance of $5.1e-3$ m if there is a charge of $5.5e-12$ C in the plates.
 - $134.136e-3$ V
 - $121.942e-3$ V
 - $97.553e-3$ V
 - $170.719e-3$ V
 - $85.359e-3$ V

5. Calculate the capacitance of a spherical capacitor made up of two concentric spherical conductors with radii 0.052 m and 0.13 m.
- A. $5.778e-12$ F
 - B. $6.741e-12$ F
 - C. $10.593e-12$ F
 - D. $7.704e-12$ F
 - E. $9.63e-12$ F
6. A capacitor consists of two concentric cylindrical shells. The radii of the shells are 0.052 m and 0.11 m. Both of them have a length of 1.5 m. Calculate the potential difference between the conductors when there is a charge of $13e-12$ C in the capacitor.
- A. 0.094 V
 - B. 0.129 V
 - C. 0.082 V
 - D. 0.117 V
 - E. 0.164 V

American online LIGS University

is currently enrolling in the
Interactive Online **BBA, MBA, MSc,**
DBA and PhD programs:

- ▶ enroll **by September 30th, 2014** and
- ▶ **save up to 16%** on the tuition!
- ▶ pay in 10 installments / 2 years
- ▶ Interactive Online education
- ▶ visit www.ligsuniversity.com to find out more!

Note: LIGS University is not accredited by any nationally recognized accrediting agency listed by the US Secretary of Education. More info [here](#).



7. Calculate the equivalent capacitance of a parallel combination of a 14 F , a 9 F and a 13 F capacitor.
- A. 35 F
 - B. 38 F
 - C. 40 F
 - D. 39 F
 - E. 36 F
8. A 14 F and a 19 F capacitors are connected in parallel and then connected to a 9 V battery. Calculate the potential difference across the 14 F capacitor.
- A. 13 V
 - B. 10 V
 - C. 9 V
 - D. 11 V
 - E. 12 V
9. A 20 F and a 7 F capacitors are connected in parallel and then connected to a 11 V battery. Calculate the charge accumulated by the 20 F capacitor.
- A. 219 C
 - B. 223 C
 - C. 218 C
 - D. 224 C
 - E. 220 C
10. An 8 F and a 19 F capacitors are connected in series and then connected to a 7 V battery. Calculate the charge accumulated by the 8 F capacitor.
- A. 23.644 C
 - B. 39.407 C
 - C. 43.348 C
 - D. 47.289 C
 - E. 27.585 C
11. A 12 F and a 5 F capacitors are connected in series and then connected to a 11 V battery. Calculate the potential difference across the 12 F capacitor.
- A. 3.235 V
 - B. 2.265 V
 - C. 2.588 V
 - D. 4.529 V
 - E. 2.912 V

Example: A 4 F capacitor is connected to a 12 V battery. Then it is disconnected from the battery and then connected to a 12 F capacitor. Calculate the charge transferred to the 12 F capacitor.

Solution: When the 4 F capacitor is connected to the 12 V battery, it will accumulate $(4)(12) \text{ C} = 48 \text{ C}$ of charge. When it is disconnected from the battery and then connected to the 12 F capacitor, charge will flow from the 4 F capacitor to the 12 F capacitor until both of them have the same potential difference. Let the charge transferred be Q , then $\Delta V_4 = \Delta V_{12}$ and

$$\frac{48 - Q}{4} = \frac{Q}{12}$$

$$48 - Q = \frac{Q}{3}$$

$$\frac{4}{3}Q = 48$$

$$Q = 36 \text{ C}$$

Series-Parallel Combination

Series-Parallel combination can be simplified by replacing each series or parallel combination by its equivalent capacitance.

Example: A series combination of a 4 F capacitor and a parallel combination of a 2 F and 3 F capacitors is connected in parallel with the series combination of a 5 F and 6 F capacitors. Then this combination, a 1 F and a 7 F capacitors are connected in series. Calculate the equivalent capacitance.

Solution: First let's replace the parallel combination of the 2 F & 3 F capacitors by their equivalent capacitance.

$$C_{23} = C_2 + C_3 = (2 + 3) \text{ F} = 5 \text{ F}$$

For the series combinations of C_{23} and C_4

$$C_{234} = \frac{C_{23}C_4}{C_{23} + C_4} = \frac{5 \cdot 4}{5 + 4} \text{ F} = \frac{20}{9} \text{ F}$$

For the series combinations of C_5 and C_6 :

$$C_{56} = \frac{C_5 C_6}{C_5 + C_6} = \frac{5 \cdot 6}{5 + 6} \text{ F} = \frac{30}{11} \text{ F}$$

C_{234} and C_{56} are in parallel. Therefore

$$C_{23456} = C_{234} + C_{56} = \left(\frac{20}{9} + \frac{30}{11} \right) \text{ F} = \frac{2250}{99} \text{ F}$$

C_1 , C_{23456} and C_7 are in series. Thus

$$\frac{1}{C_{eq}} = \frac{1}{C_1} + \frac{1}{C_{23456}} + \frac{1}{C_7} = \left(\frac{1}{1} + \frac{1}{\frac{2250}{99}} + \frac{1}{7} \right) \text{ F} = \frac{18693}{15750} \text{ F}$$

$$C_{eq} = \frac{15750}{18693} \text{ F}$$

Example: The parallel combination of a 4 F and 6 F capacitors is connected in series with a 2 F capacitor. Then the combination is connected to a 12 V potential difference. (Let $C_2 = 2 \text{ F}$; $C_4 = 4 \text{ F}$; $C_6 = 6 \text{ F}$.)

.....Alcatel-Lucent 

www.alcatel-lucent.com/careers

What if you could build your future and create the future?

One generation's transformation is the next's status quo. In the near future, people may soon think it's strange that devices ever had to be "plugged in." To obtain that status, there needs to be "The Shift".



a) Find the equivalent capacitance of the combination.

Solution:

C_4 and C_6 are in parallel.

$$C_{46} = C_4 + C_6 = (4+6) \text{ F} = 10 \text{ F}$$

C_{46} and C_2 are in series.

$$C_{eq} = \frac{C_2 C_{46}}{C_2 + C_{46}} = \left(\frac{2 \cdot 10}{2+10} \right) \text{ F} = \frac{20}{12} \text{ F} = \frac{5}{3} \text{ F}$$

b) Calculate the total charge accumulated by the combination.

Solution:

$$Q = C_{eq} \Delta V = \frac{5}{3}(12) \text{ F} = 20 \text{ C}$$

c) Find the charge accumulated by the 2F capacitor.

Solution:

Since C_2 and C_{46} are in series

$$Q_2 = Q_{46} = Q = 20 \text{ C}$$

d) Calculate the potential difference across the 2 F capacitor.

Solution:

$$V_2 = \frac{Q_2}{C_2} = \frac{20}{2} \text{ V} = 10 \text{ V}$$

e) Calculate the potential difference across the 4 F & 6 F capacitors.

Solution: Since C_4 and C_6 are in parallel.

$$V_4 = V_6 = V_{46}$$

$$V_{46} = \frac{Q_{46}}{C_{46}} = \frac{20}{10} \text{ V} = 2 \text{ V}$$

$$V_4 = V_6 = 2 \text{ V}$$

f) Calculate the charges accumulated by the 4 F and 6 F capacitors.

Solution:

$$Q_4 = C_4 V_4 = (4)(2) \text{ C} = 8 \text{ C}$$

$$Q_6 = C_6 V_6 = (6)(2) \text{ C} = 12 \text{ C}$$

Energy Stored by a Capacitor

As a small charge dq is added to a capacitor when its potential difference is $\Delta V = \frac{q}{C}$, the energy of the capacitor increases by $dU = \Delta V dq = \frac{q}{C} dq$. As the charge increases from zero to a charge Q , the total energy stored by the capacitor is obtained by integrating from zero to Q : $Q: U = \int dU = \int_0^{\Delta V} \frac{q}{C} dq$. Therefore the electrical energy stored by a capacitor of capacitance C when the charge stored by the capacitor is Q is given by

$$U = \frac{1}{2} \frac{Q^2}{C}$$

Replacing C by $\frac{Q}{\Delta V}$ or replacing Q by $C\Delta V$, the following alternative expressions for the energy can be obtained.

$$U = \frac{1}{2} Q\Delta V = \frac{1}{2} C\Delta V^2$$

Energy Density of a parallel plate capacitor

If the area of the plates is A and the separation between the plates is d , then the volume between the parallel plate capacitor is Ad . The electrical energy density (u) is obtained by dividing the total energy by its volume: $u = \frac{U}{Ad} = \frac{\frac{1}{2} C A V^2}{Ad}$. But $\Delta V = Ed$ (where E is the electric field between the plates and $C = \frac{\epsilon_0 A}{d}$). Therefore $u = \frac{\frac{1}{2} \epsilon_0 A (Ed)^2}{Ad}$ and the electrical energy density is given in terms of the electric field as

$$u = \frac{1}{2} \epsilon_0 E^2$$

Capacitors with Dielectrics

A dielectric is an insulator placed between the conductors of a capacitor. A dielectric is used to increase the capacitance of a capacitor. The charges in the plates of the capacitor will set up an electric field directed from the positive plate towards the negative plate. Let the strength of this field be E_0 . This is also the field when the medium inside is vacuum (or approximately air). Now suppose the medium is replaced by an insulator. This electric field will exert force on the molecules of the dielectric. The negative part of a molecule will be pulled towards the positive plate and the positive part of the molecule will be pulled towards the negative plate. Thus, the molecules of the dielectric will set up their own electric field directed from their positive end towards their negative end which is opposite to the electric field set up by the charges on the plates. The net electric field between the plates is the field due to the charges in the plates minus the field due to the molecules of the dielectric.

Thus, the electric field strength with a dielectric is less than the field strength without a dielectric. The ratio between the field strength without a dielectric (E_0) to the field strength with a dielectric (E) is defined to be dielectric constant (κ) of the dielectric.

$$\kappa = \frac{E_0}{E}$$



In the past four years we have drilled

81,000 km

That's more than **twice** around the world.

Who are we?
We are the world's leading oilfield services company. Working globally—often in remote and challenging locations—we invent, design, engineer, manufacture, apply, and maintain technology to help customers find and produce oil and gas safely.

Who are we looking for?
We offer countless opportunities in the following domains:

- Engineering, Research, and Operations
- Geoscience and Petrotechnical
- Commercial and Business

If you are a self-motivated graduate looking for a dynamic career, apply to join our team.

careers.slb.com

What will you be?

Schlumberger

Dielectric constant is one for vacuum but greater than for all insulators because $E < E_0$. The potential difference between the plates (ΔV_0) when there is no dielectric (i.e. vacuum) is given by $\Delta V_0 = E_0 d$ where d is the separation between the plates and the potential difference (ΔV) with the dielectric is given by $\Delta V = Ed$. But $E = \frac{E_0}{\kappa}$. Therefore $\Delta V = \frac{E_0 d}{\kappa}$ or

$$\Delta V = \frac{\Delta V_0}{\kappa}$$

The effect of a dielectric is to decrease the potential difference. As a dielectric is inserted the charge on the plates remain the same ($Q = Q_0$). The capacitance of the capacitor without a dielectric is given by $C_0 = \frac{Q_0}{\Delta V_0}$ and the capacitance with a dielectric of dielectric constant κ is $C = \frac{Q_0}{\Delta V}$. Replacing ΔV by $\frac{\Delta V_0}{\kappa}$ shows that the effect of a dielectric is to increase the capacitance of the capacitor by a factor of κ .

$$C = \kappa C_0$$

When a dielectric is inserted between the conductors of a capacitor, the charge remains the same, the electric field decreases by a factor of $\frac{1}{\kappa}$, the potential difference decreases by a factor of $\frac{1}{\kappa}$ and the capacitance increases by a factor of κ .

Example: A parallel plate capacitor whose plates are separated by a distance of 4 mm has a capacitance of 0.4425 pF when the plates are separated by air. It is connected to a 10 V battery and then disconnected. Then the space between the plates is filled with an insulator of dielectric constant 1.5.

a) Calculate its capacitance.

Solution:

$$C_0 = 4.425 \times 10^{-13} \text{ F}; \kappa = 1.5; C = ?$$

$$C = \kappa C_0 = (1.5)(4.425 \times 10^{-13} \text{ F}) = 6.6 \times 10^{-13} \text{ F}$$

b) Calculate the potential difference between the plates.

Solution:

$$\Delta V_0 = 10 \text{ V}; \Delta V = ?$$

$$\Delta V = \frac{\Delta V_0}{\kappa} = \frac{10}{1.5} \text{ V} = 6.67 \text{ V}$$

c) Calculate the strength of the electric field.

Solution:

$$d = 0.004 \text{ m}; E = ?$$

$$E_0 = \frac{\Delta V_0}{d} = \frac{10}{0.004} \text{ N/C} = 2.5 \times 10^3 \text{ V}$$

$$E = \frac{E_0}{\kappa} = \frac{2.5 \times 10^3}{1.5} \text{ N/C} = 1.6 \times 10^3 \text{ N/C}$$

d) Calculate the charge on the plates.

Solution:

$$Q = ?$$

$$Q = Q_0 = C_0 \Delta V_0 = 4.425 \times 10^{-13} \times 10 \text{ F} = 4.425 \times 10^{-12} \text{ F}$$

Example: A parallel plate capacitor has an area of 0.002 cm^2 and a separation of 0.1 m . the bottom half of the capacitor (when the plates are in a vertical position) is filled with a dielectric of dielectric constant 2. Calculate the capacitance of the capacitor.

Solution: This can be treated as the parallel combination of two capacitors whose areas are half of the total area. $C = C_a + C_d$ where C_a stands for the capacitance of the upper half with air and C_d stands for the capacitance of the lower half with dielectric.

$$C_a = \frac{\epsilon_0 \frac{A}{2}}{d} = \frac{8.85 \times 10^{-12} \left(\frac{0.02}{2} \right)}{0.1} \text{ F} = 8.85 \times 10^{-11} \text{ F}$$

$$C_d = \frac{\kappa \epsilon_0 \frac{A}{2}}{d} = \frac{2 \left(8.85 \times 10^{-12} \right) \left(\frac{0.02}{2} \right)}{0.1} \text{ F} = 17.7 \times 10^{-11} \text{ F}$$

$$C = C_a + C_d = (8.85 + 17.7) \times 10^{-11} \text{ F} = 26.55 \times 10^{-11} \text{ F}$$

Example: A parallel capacitor has an area of 0.02 cm^2 and a separation of 0.1 m . Suppose now the left half (when the plates in vertical position) is filled with dielectric of dielectric constant 2. Calculate the capacitance of the capacitor.

Solution: This can be treated as the series combination of two capacitors whose separation is half of the total separation. $C = \frac{C_a C_d}{C_a + C_d}$ where C_a stands for the capacitance of the one with air and C_d stands for the capacitance of the one with dielectric

$$C_a = \frac{\epsilon_0 A}{d/2} = \frac{8.85 \times 10^{-12} (0.02)}{0.01/2} \text{ F} = 25.4 \times 10^{-11} \text{ F}$$

$$C_d = \frac{\kappa \epsilon_0 A}{d/2} = \frac{2 (8.85 \times 10^{-12}) (0.02)}{0.05} \text{ F} = 70.8 \times 10^{-11} \text{ F}$$

$$C = \frac{(35.4 \times 10^{-11})(70.8 \times 10^{-11})}{35.4 \times 10^{-11} + 70.8 \times 10^{-11}} \text{ F} = 23.6 \times 10^{-11} \text{ F}$$



Maastricht University

*Leading
in Learning!*

**Join the best at
the Maastricht University
School of Business and
Economics!**

Top master's programmes

- 33rd place Financial Times worldwide ranking: MSc International Business
- 1st place: MSc International Business
- 1st place: MSc Financial Economics
- 2nd place: MSc Management of Learning
- 2nd place: MSc Economics
- 2nd place: MSc Econometrics and Operations Research
- 2nd place: MSc Global Supply Chain Management and Change

Sources: Keuzegids Master ranking 2013; Elsevier 'Beste Studies' ranking 2012; Financial Times Global Masters in Management ranking 2012

**Maastricht
University is
the best specialist
university in the
Netherlands
(Elsevier)**

**Visit us and find out why we are the best!
Master's Open Day: 22 February 2014**

www.mastersopenday.nl

Practice Quiz 4.2

Choose the best answer

1. Calculate the equivalent capacitance of the parallel combination of an 8 F capacitor and a series combination of a 15 F and 16 F capacitors.
A. 18.89 F
B. 22.039 F
C. 14.168 F
D. 11.019 F
E. 15.742 F
2. The parallel combination of a 2 F and a 3 F capacitors is connected in series with a 10 F capacitor. And then the combination is connected to a potential difference of 30 V . Calculate the charge accumulated by the 10 F capacitor.
A. 80 C
B. 100 C
C. 90 C
D. 130 C
E. 60 C
3. The parallel combination of an 8 F and a 24 F capacitors is connected in series with a 7 F capacitor. And then the combination is connected to a potential difference of 45 V . Calculate the potential difference across the 7 F capacitor.
A. 51.692 V
B. 44.308 V
C. 40.615 V
D. 36.923 V
E. 48 V
4. A 5.5 F capacitor is connected to a 14 V battery. Then the capacitor is disconnected from the battery and connected to another neutral capacitor (in parallel) of capacitance 13.5 F . Calculate the amount of charge transferred to the 13.5 F capacitor. (Hint: charge will flow from the charged capacitor to the new capacitor until both capacitors have the same potential difference).
A. 38.297 C
B. 76.595 C
C. 65.653 C
D. 60.182 C
E. 54.711 C

5. A(n) 15 V battery is connected to a parallel combination of a series combination of a(n) 3 F and 14 F capacitors and a series combination of a(n) 6 F and 17 F capacitors. Calculate the charge accumulated by the 3 F capacitor.
- A. 29.647 C
 - B. 25.941 C
 - C. 37.059 C
 - D. 51.882 C
 - E. 40.765 C
6. A(n) 15 V battery is connected to a series combination of a parallel combination of a(n) 5 F and 12 F capacitors and a parallel combination of a(n) 7 F and a(n) 16 F capacitors. Calculate the charge accumulated by the 5 F capacitor.
- A. 56.063 C
 - B. 38.813 C
 - C. 60.375 C
 - D. 34.5 C
 - E. 43.125 C
7. Calculate the electrical energy stored by a capacitor that accumulates 0.34 C of charge when connected to a 10 V battery.
- A. 1.19 J
 - B. 1.87 J
 - C. 1.02 J
 - D. 1.36 J
 - E. 1.7 J
8. A parallel plate capacitor of area $7.2e-4\text{ m}^2$ and separation $6.1e-3\text{ m}$ is connected to an 8.3 V battery. Calculate the electric energy density between the plates.
- A. $5.729e-6\text{ J/m}^3$
 - B. $8.185e-6\text{ J/m}^3$
 - C. $6.548e-6\text{ J/m}^3$
 - D. $7.366e-6\text{ J/m}^3$
 - E. $4.911e-6\text{ J/m}^3$

9. A $6.3e-6$ F parallel plate capacitor where the plates are separated by a distance of $6.3e-3$ m is connected to a 19 V battery. Then the battery is disconnected from the battery and the space between the plates is filled with an insulator of dielectric constant 1.3 . Calculate the magnitude of the electric field between the plates.
- A. $1.547e3$ N/C
 - B. $3.016e3$ N/C
 - C. All of the other choices are incorrect
 - D. $2.32e3$ N/C
 - E. $3.921e3$ N/C
10. A parallel plate capacitor has an area of $8.2e-4$ m² and a separation of $1.5e-3$ m separation. The top half and the bottom half of the space between the plates are filled with insulators of dielectric constants 1.5 and 1.2 respectively. Calculate the capacitance of the capacitor.
- A. $4.568e-12$ F
 - B. $7.178e-12$ F
 - C. $6.525e-12$ F
 - D. $3.915e-12$ F
 - E. $5.22e-12$ F



> Apply now

REDEFINE YOUR FUTURE
**AXA GLOBAL GRADUATE
PROGRAM 2015**

redefining / standards 

agence.cdg - © Photonostop

5 CURRENT AND RESISTANCE

Your goal for this chapter is to learn about current, current density, resistors, Ohm's Law and rate of dissipation of electrical energy in a resistor.

Current (I) is defined to be the rate at which charges cross a cross sectional area. If a charge dQ crosses a cross-sectional area in an infinitesimal time interval dt then current is given as

$$I = \frac{dQ}{dt}$$

If the rate of flow is uniform, then current can be evaluated as the ratio of the total charge (Q) crossing the cross-section to the time interval (Δt) the charge took to cross the cross-section.

$$I = \frac{Q}{\Delta t}$$

Unit of measurement of current is coulomb/second which is defined to be the Ampere abbreviated as A. Charges are carried by electrons which are negatively charged. But, conventionally it is assumed that charges are carried by positive charges.

Example: If 10^{10} electrons cross a cross-sectional area in 1 ms, calculate the average current.

Solution:

$$N = 10^{10}; e = -1.6 \times 10^{-19} \text{ C}; \Delta t = 0.001 \text{ s}; I = ?$$

$$Q = N|e| = 10^{10} \times 1.6 \times 10^{-19} \text{ C}; 1.6 \times 10^{-9} \text{ C}$$

$$I_{av} = \frac{Q}{\Delta t} = \frac{1.6 \times 10^{-9}}{10^{-3}} \text{ A} = 1.6 \times 10^{-6} \text{ A}$$

Current Density (\vec{J}) is defined to be amount of charge that crosses a cross-section per a unit time per a unit perpendicular area. In other words, its magnitude is defined to be current that crosses a cross-section per a unit perpendicular area (A_{\perp}).

$$J = \frac{I}{A_{\perp}}$$

The unit of measurement of current density is A/m^2 . Current density is a vector quantity. Its direction is the direction of movement (velocity) of the charges which are assumed to be positive charges. Current is equal to the product of the magnitude of the current density and the component of the area of the cross-section in the direction of the current density (Direction of area is perpendicular to the cross-section in a counterclockwise direction). In other words current is equal to the dot product between the current density and the area of the cross-section.

$$I = \vec{J} \cdot \vec{A} = JA \cos(\theta)$$

θ and A stand for the angle formed between current density and area and the magnitude of the area respectively. This expression for the current implies that the current is positive when it is flowing in a counterclockwise direction and negative when it flows in a clockwise direction. If the current density is not uniform over the cross-section, then the surface integral over the cross-section should be used.

$$I = \int \vec{J} \cdot d\vec{A}$$

Drift Velocity of Electrons

Normally the electrons are randomly colliding with each other. If there is no electric field, the net velocity of the electrons will be zero. But if there is a net electric field, the electrons will have a net velocity opposite to the directions of the electric field. This velocity is called the drift velocity of electrons. Even though the carriers of charges are negative charges (electrons), conventionally it is assumed that the carriers of charge are positive charges. Thus the direction of current density is taken to be the direction of movement of positive charges which is the same as the direction of the electric field.

Consider carriers of charge q crossing a cross-sectional area (A_{\perp}) with a drift velocity v_d . Suppose the charges travel a distance Δx in a time interval Δt . (That is, $v_d = \frac{\Delta x}{\Delta t}$).

Let n represent the number of charges per unit volume or concentration of charges. Therefore the total amount of charge that crosses the cross-sectional is in time interval Δt is $n\Delta x A_{\perp} q$ (where $\Delta x A_{\perp}$ is the volume of the cylinder of base A_{\perp} and height Δx). That is $Q = n\Delta x A_{\perp} q$. That is $I = \frac{Q}{\Delta t} = \frac{n\Delta x A_{\perp} q}{\Delta t}$. But $\frac{\Delta x}{\Delta t} = v_d$. Hence, the current and the current density are related with the drift velocity as follows:

$$\begin{aligned} I &= n v_d A_{\perp} q \\ J &= \frac{I}{A_{\perp}} = n v_d q \\ \vec{J} &= n q \vec{v}_d \end{aligned}$$

Example: Aluminum has a density of $2.7 \times 10^3 \text{ kg/m}^3$. Aluminum has 3 free (valence) electrons per atom. If there is a current of 2 A in an aluminum wire of cross-sectional radius of 4 mm, calculate the drift velocity of the electrons.

Solution: The atomic mass of Al is 27 u. This means the gram molecular weight (M_g) of aluminum is 27 g. In one gram molecular weight of any substance there are Avogadro number of atoms ($N_A = 6.02 \times 10^{23}$). Therefore the number of atoms per unit volume is equal to the ratio between Avogadro number (N_A) and the volume of one gram molecular weight (V_g). And since there are 3 free electrons per atom, the number of electrons per unit volume (n) is three times the number of atoms per unit volume.

$$\rho_{Al} = 2.7 \times 10^3 \text{ kg/m}^3; I = 2 \text{ A}; r = 0.004 \text{ m}; M_g = 0.027 \text{ kg}; A_{\perp} = \pi r^2 = \pi (4 \times 10^{-3})^2 = 5 \times 10^{-5} \text{ m}^2$$

$$V_g = \frac{M_g}{\rho_{Al}} = \frac{0.027}{2.7 \times 10^3} \text{ m}^3 = 10^{-5} \text{ m}^3$$

$$n = 3 \frac{N_A}{V_g} = \frac{6.02 \times 10^{23}}{10^{-5}} \text{ 1/m}^3 = 18.06 \times 10^{28} \text{ 1/m}^3$$

$$q = |e| = 1.6 \times 10^{-19} \text{ C}$$

$$v_d = \frac{I}{n A_{\perp} q} = \frac{2}{18.06 \times 10^{28} \times 5 \times 10^{-5} \times 1.6 \times 10^{-19}} \text{ m/s} = 1.4 \times 10^{-6} \text{ m/s}$$



Empowering People. Improving Business.

BI Norwegian Business School is one of Europe's largest business schools welcoming more than 20,000 students. Our programmes provide a stimulating and multi-cultural learning environment with an international outlook ultimately providing students with professional skills to meet the increasing needs of businesses.

BI offers four different two-year, full-time Master of Science (MSc) programmes that are taught entirely in English and have been designed to provide professional skills to meet the increasing need of businesses. The MSc programmes provide a stimulating and multi-cultural learning environment to give you the best platform to launch into your career.

- MSc in Business
- MSc in Financial Economics
- MSc in Strategic Marketing Management
- MSc in Leadership and Organisational Psychology

BI NORWEGIAN BUSINESS SCHOOL

EFMD **EQUIS** ACCREDITED

www.bi.edu/master

Ohm's Law

Ohm's law states that the current density and the electric field in metals are directly proportional.

$$\vec{J} = \sigma \vec{E}$$

σ is a material constant called the conductivity of the material. Since the electric field is proportional to the potential difference across the material (resistor) and the current through the resistor is proportional to the current density, another way of stating Ohm's Law is that the potential difference across a resistor is proportional to the current flowing through the resistor. The constant of proportionality between the potential difference and the current is called the resistance (R) of the resistor.

$$\Delta V = IR$$

The unit of measurement for resistance is V/A which is defined to be the Ohm abbreviated as Ω . The circuit symbol for a resistor is



Figure 8.1

Resistance of a Wire of Length l and Cross Sectional Area A

If ΔV is the potential difference across the ends of the wire, then $\Delta V = E\ell$ where E is the electric field in the wire. And if I is the current in the wire, then $I = JA$ where J stands for the current density in the wire. Therefore the resistance of the wire (R_ℓ) may be expressed in terms of field strength and current density as $R = \frac{\Delta V}{I} = \frac{E\ell}{JA}$. And since $J = \sigma E$, it follows that

$$R_\ell = \frac{1}{\sigma} \frac{\ell}{A}$$

The inverse of the conductivity is defined to be the resistivity $\left(\rho = \frac{1}{\sigma}\right)$ of the material and

$$R_\ell = \rho \frac{\ell}{A}$$

The resistance of a wire is directly proportional to the length of the wire and inversely proportional to the cross-sectional area of the wire. The unit of measurement for resistivity is Ωm .

Example: Find an expression for the resistance of a coaxial cable of inner radius a and outer radius b . The resistance of the material is ρ . The length of the wire is L . Assume the current is flowing radially outwards.

Solution: Consider a cylindrical shell of radius r ($a < r < b$) of thickness dr . Then for a radial current the cross-sectional area is the surface area of the shell which is equal to $2\pi rL$ and the length of the shell in the radial directions is dr . Therefore the resistance (dR) of the shell of thickness dr is given by $dR = \frac{\rho dr}{2\pi Lr}$ and the total resistance (R) is obtained by

$$\text{integrating from } a \text{ to } b: R = \int_{r=a}^{r=b} \frac{\rho dr}{2\pi Lr} = \frac{\rho}{2\pi L} \ln\left(\frac{b}{a}\right)$$

Dependence of Resistivity on Temperature

The change in resistivity ($\Delta\rho$) of a material due to the change in temperature (ΔT) is directly proportional to the change in temperature and to the initial resistivity (ρ_0).

$$\Delta\rho = \alpha\rho_0 \Delta T$$

α is a material constant called temperature coefficient of temperature. Its unit of measurement is $1/^\circ\text{C}$. If the value of the resistivity at a particular temperature is desired the above equation can be simplified as follows: $\Delta\rho = \rho - \rho_0 = \alpha \rho_0 (T - T_0)$ and

$$\rho = \rho_0 \left[1 + \alpha (T - T_0) \right]$$

Example: Silver has a resistivity of $1.59 \times 10^{-8} \Omega\text{m}$ at a temperature of 20°C . Its temperature coefficient is $3.8 \times 10^{-3} 1/^\circ\text{C}$. Calculate its resistivity at a temperature of 120°C .

Solution:

$$\rho_0 = 1.59 \times 10^{-8} \Omega\text{m}; T_0 = 20^\circ\text{C}; T = 120^\circ\text{C}; \alpha = 3.8 \times 10^{-3} 1/^\circ\text{C}; \rho = ?$$

$$\rho = \rho_0 \left[1 + \alpha (T - T_0) \right] = 1.59 \times 10^{-8} \left[1 + 3.8 \times 10^{-3} (120 - 20) \right] \Omega\text{m} = 2.862 \times 10^{-8} \Omega\text{m}$$

Example: By how much would the resistivity of a silver wire change when its temperature changes by 200°C (Assume initial temp to be 20°C).

Solution:

$$\rho_0 = 1.59 \times 10^{-8} \Omega\text{m}; \Delta T = 200^\circ\text{C}; \alpha = 3.8 \times 10^{-3} 1/^\circ\text{C}; \Delta\rho = ?$$

$$\Delta\rho = \alpha\rho_0 \Delta T = (3.8 \times 10^{-3}) (1.59 \times 10^{-8}) (200) \Omega\text{m} = 1.2 \times 10^{-8} \Omega\text{m}$$

Practice Quiz 5.1

Choose the best answer

1. The SI unit of measurement for resistivity of a material is
 - A. $1 / (\text{degree Centigrade})$
 - B. Ohm * meter
 - C. Ohm
 - D. Ohm / meter
 - E. Volt / meter

2. Which of the following is a correct statement?
 - A. The resistance of a wire is directly proportional to the length of the wire
 - B. Ohm's law states that the current density in a conductor is inversely proportional to the electric field it is subjected to.
 - C. Current is measured by a device called electroscopes.
 - D. The resistance of a wire is directly proportional to the cross-sectional area of the wire.
 - E. A resistor is a device that converts non-electrical energy to electrical energy.

Need help with your dissertation?

Get in-depth feedback & advice from experts in your topic area. Find out what you can do to improve the quality of your dissertation!

Get Help Now



Go to www.helpmyassignment.co.uk for more info



3. If 0.432 C of charge crosses a cross-sectional area of a wire in 0.53 seconds, calculate the average current flowing through the wire.
- A. 4.075 A
 - B. 3.26 A
 - C. 0.815 A
 - D. 1.223 A
 - E. 0.652 A
4. Calculate the current flowing in a copper wire of cross-sectional radius $5.6e-3\text{ m}$ if the free electrons are moving with a drift velocity of $5.6e-6\text{ m/s}$. (Gram molecular weight and density of copper are 63.5 g and 8950 kg/m^3 respectively. There are Avogadro's number of atoms ($6.02e23$) in one gram molecular weight of any substance. The charge of an electron is $1.6e-19\text{ C}$).
- A. 8.239 A
 - B. 8.988 A
 - C. 4.494 A
 - D. 7.49 A
 - E. 5.243 A
5. If the amount of charge that crosses a cross section of a silver wire of radius $1.7e-3\text{ m}$ per a unit time is $8.3e-3\text{ A}$, calculate the electric field responsible for the flow of charge. Resistivity of silver is $1.59e-8\ \Omega\text{ m}$. Assume a complete circuit.
- A. $10.175e-6\text{ N/C}$
 - B. $15.989e-6\text{ N/C}$
 - C. $17.443e-6\text{ N/C}$
 - D. $14.535e-6\text{ N/C}$
 - E. $8.721e-6\text{ N/C}$
6. Calculate the potential difference across a $13\ \Omega$ resistor when a current of 1.8 A flows through it.
- A. 93.6 V
 - B. 18.72 V
 - C. 14.04 V
 - D. 23.4 V
 - E. 35.1 V

7. An 18.5 m long silver wire has a resistance of 0.003Ω . Calculate its cross-sectional area. (Silver has a resistivity of $1.59e-8 \Omega \text{ m}$.)
- A. $0.686e-4 \text{ m}^2$
 - B. $1.079e-4 \text{ m}^2$
 - C. $1.373e-4 \text{ m}^2$
 - D. $0.981e-4 \text{ m}^2$
 - E. $0.784e-4 \text{ m}^2$
8. Calculate the resistance of spherical copper shell of inner radius 0.01 m and outer radius 0.06 m. Assume the current is flowing radially outward from the inner surface to the outer surface. The resistivity of copper is $1.7e-8 \Omega \text{ m}$.
- A. $10.146e-8 \Omega$
 - B. $11.273e-8 \Omega$
 - C. $15.783e-8 \Omega$
 - D. $14.656e-8 \Omega$
 - E. $13.528e-8 \Omega$
9. The two ends of a nichrome wire of length 14.5 m and cross-sectional radius 0.00175 m are connected to the terminals of a 5 V battery. Calculate the current flowing through the wire. (Nichrome has a resistivity of $150e-8 \Omega \text{ m}$.)
- A. 2.875 A
 - B. 1.769 A
 - C. 1.327 A
 - D. 2.433 A
 - E. 2.212 A
10. Lead has a resistivity of $22e-8 \Omega \text{ m}$ at a temperature of 20°C . Calculate its resistivity at a temperature of 150°C . (Lead has resistivity temperature coefficient of $3.9e-3/^\circ\text{C}$.)
- A. $19.892e-8 \Omega \text{ m}$
 - B. $33.154e-8 \Omega \text{ m}$
 - C. $36.469e-8 \Omega \text{ m}$
 - D. $23.208e-8 \Omega \text{ m}$
 - E. $26.523e-8 \Omega \text{ m}$

11. A certain sample of lead is at a temperature of 20°C . (Lead has a resistivity of $22e-8\ \Omega\ \text{m}$ at a temperature of 20°C .) By how much would its resistivity change, when its temperature changes by 70°C . (Lead has resistivity temperature coefficient of $3.9e-3/^\circ\text{C}$.)
- A. $3.604e-8\ \Omega\ \text{m}$
B. $4.204e-8\ \Omega\ \text{m}$
C. $6.006e-8\ \Omega\ \text{m}$
D. $7.207e-8\ \Omega\ \text{m}$
E. $5.405e-8\ \Omega\ \text{m}$

Dependence of Resistance on Temperature

Since resistance is proportional to resistivity ($R = \frac{\rho \ell}{A}$ for a given ℓ & A), the same proportionality as resistivity applies. That is, change in resistance (ΔR) of a resistor is directly proportional to change in temperature and to the initial resistance (R_0):

$$\Delta R = R_0 \alpha \Delta T$$

Also, since $\Delta R = R - R_0 = R_0 \alpha (T - T_0)$

$$R = R_0 \left[1 + \alpha (T - T_0) \right]$$



Brain power

By 2020, wind could provide one-tenth of our planet's electricity needs. Already today, SKF's innovative know-how is crucial to running a large proportion of the world's wind turbines.

Up to 25 % of the generating costs relate to maintenance. These can be reduced dramatically thanks to our systems for on-line condition monitoring and automatic lubrication. We help make it more economical to create cleaner, cheaper energy out of thin air.

By sharing our experience, expertise, and creativity, industries can boost performance beyond expectations. Therefore we need the best employees who can meet this challenge!

The Power of Knowledge Engineering

Plug into The Power of Knowledge Engineering.
Visit us at www.skf.com/knowledge

SKF

Example: A silver wire (resistivity $1.59 \times 10^{-8} \Omega\text{m}$ and temperature coefficient of $3.8 \times 10^{-3} \text{ } 1/^{\circ}\text{C}$ at 20°C) has a length of 10 m and a cross-sectional radius of 2 mm. Calculate the current flowing through it when it is connected to a 0.5 V battery at a temperature of 120°C .

Solution:

$$\rho_{20} = 1.59 \times 10^{-8} \Omega\text{m}; \ell = 10 \text{ m}; r = 0.002 \text{ m}; \alpha = 3.8 \times 10^{-3} \text{ } 1/^{\circ}\text{C}; R_{120} = ?$$

$$A = \pi r^2 = \pi (2 \times 10^{-3})^2 \text{ m}^2 = 12.56 \times 10^{-6} \text{ m}^2$$

$$R_{20} = \frac{\rho_{20} \ell}{A} = \frac{(1.59 \times 10^{-8})(10)}{12.56 \times 10^{-6}} \Omega = 0.012 \Omega$$

$$I_{20} = \frac{\Delta V}{R_{20}} = \frac{0.5}{0.012} \text{ A} = 41.7 \text{ A}$$

$$R_{120} = R_{20} \left[1 + \alpha (T_{120} - T_{20}) \right] = 0.012 \left[1 + 3.8 \times 10^{-3} (120 - 20) \right] \Omega = 0.0166 \Omega$$

$$I_{120} = \frac{\Delta V}{R_{120}} = \frac{0.5}{0.0166} \text{ A} = 30.17 \text{ A}$$

Electrical Power and Energy

Electrical power (P) dissipated in a resistor is defined to be equal to the rate of conversion of electrical energy to non-electrical energy in the resistor. If ΔU is the amount of electrical energy converted to non-electrical energy in a time interval Δt , then the electrical power dissipated in a resistor is given as

$$P = \frac{\Delta U}{\Delta t}$$

Unit of measurement of power J/s which is defined to be the Watt abbreviated as W. If a charge q is displaced through a potential difference ΔV , then $\Delta U = q\Delta V$ and $P = \frac{q\Delta V}{\Delta t}$. But $\frac{q}{\Delta t}$ is current. Therefore, the power can be written in terms of current and potential difference as

$$P = I \Delta V$$

Power dissipated in a resistor is equal to the product of the current through the resistor and the potential difference across the resistor. Also substituting for ΔV from $\Delta V = RI$ or substituting for I from $I = \frac{\Delta V}{R}$, the following alternate expressions for the power can be obtained.

$$P = I^2 R = \frac{\Delta V^2}{R}$$

Example: A $10\ \Omega$ resistor is connected to a 6 V battery.

a) Calculate the power dissipated in the resistor.

Solution:

$$R = 10\ \Omega; \Delta V = 6\ \text{V}; P = ?$$

$$P = \frac{\Delta V^2}{R} = \frac{6^2}{10}\ \text{W} = 3.6\ \text{W}$$

b) Calculate the energy dissipated in the resistor in 0.2 seconds.

Solution:

$$\Delta t = 0.2\ \text{s}; \Delta U = ?$$

$$\Delta U = P\Delta t = (3.6)(0.2)\ \text{J} = 0.72\ \text{J}$$

c) Calculate the current flowing through it.

Solution:

$$I = ?$$

$$I = \frac{\Delta V}{R} = \frac{6}{10}\ \text{A} = 0.6\ \text{A}$$

Example: When a 100 watt lamp is connected to a certain potential difference, a current of $2\ \text{A}$ flows across it.

a) Calculate the potential difference.

Solution:

$$P = 100\ \text{W}; I = 2\ \text{A}; \Delta V = ?$$

$$\Delta V = \frac{P}{I} = \frac{100}{2}\ \text{V} = 50\ \text{V}$$

b) Calculate its resistance.

Solution:

$$R = ?$$

$$R = \frac{\Delta V}{I} = \frac{50}{2}\ \Omega = 25\ \Omega$$

The *kilo-Watt-hour* is a unit of energy defined to be equal to the amount of energy dissipated by 1 kW device when used for one hour. Therefore

$$\text{kWh} = (1000 \text{ W})(3600 \text{ s}) = 3.6 \times 10^6 \text{ J}$$

Example: If electrical energy costs 10 cents per kilo Watt hour, how much would it cost to run a 100 W lamp for 30 days at 5 hours per day?

Solution:

$$P = 100 \text{ W} = 0.1 \text{ kW}; \Delta t = 30 \times 5 \text{ hr} = 150 \text{ hr}; \text{price} = 10 \text{ cents/kwh}; \text{cost} = ?$$

$$\Delta U = P\Delta t = 0.1 \times 150 \text{ kWh} = 15 \text{ kWh}$$

$$\text{cost} = (\Delta U)(\text{price}) = 15 \times 10 \text{ cents} = 150 \text{ cents} = \$1.5$$

What do you want to do?

No matter what you want out of your future career, an employer with a broad range of operations in a load of countries will always be the ticket. Working within the Volvo Group means more than 100,000 friends and colleagues in more than 185 countries all over the world. We offer graduates great career opportunities – check out the Career section at our web site www.volvogroup.com. We look forward to getting to know you!

VOLVO
AB Volvo (publ)
www.volvogroup.com

VOLVO TRUCKS | RENAULT TRUCKS | MACK TRUCKS | VOLVO BUSES | VOLVO CONSTRUCTION EQUIPMENT | VOLVO PENTA | VOLVO AERO | VOLVO IT
VOLVO FINANCIAL SERVICES | VOLVO 3P | VOLVO POWERTRAIN | VOLVO PARTS | VOLVO TECHNOLOGY | VOLVO LOGISTICS | BUSINESS AREA ASIA

Practice Quiz 5.2

Choose the best answer

- Which of the following is a correct statement?
 - Change in the resistance of a resistor is inversely proportional to the change in its temperature.
 - Change in the resistance of a resistor is inversely proportional to its initial resistance.
 - Change in the resistance of a resistor is inversely proportional to its temperature.
 - Change in the resistance of a resistor is directly proportional to its temperature.
 - Kilo Watt Hour (kWh) is a unit of measurement of energy.
- Covert 8.5 J to kWh.
 - $1.417e-6$ kWh
 - $2.597e-6$ kWh
 - $1.653e-6$ kWh
 - $2.361e-6$ kWh
 - $1.889e-6$ kWh
- A resistor made of silver has a resistance of 95Ω at a temperature of 20°C . To what temperature should it be heated if its resistance is to increase to 109Ω . (Silver has a resistivity temperature coefficient of $3.8e-3/^\circ\text{C}$.)
 - 47.025°C
 - 58.781°C
 - 41.147°C
 - 52.903°C
 - 82.294°C
- A resistor made of silver has a resistance of 93Ω at a temperature of 20°C . By how much should its temperature change if its resistance is to increase by 6%. (Silver has a resistivity temperature coefficient of $3.8e-3/^\circ\text{C}$.)
 - 20.526°C
 - 15.789°C
 - 18.947°C
 - 14.211°C
 - 9.474°C

5. The ends of a lead wire of length 15.3 m and cross-sectional radius 0.004 m are connected to a 0.13 V battery at a temperature of 100 °C. Calculate the current flowing through the wire. (Lead has a resistivity of $22e-8$ Ω m at 20 °C and a resistivity temperature coefficient of $3.9e-3$ /°C.)
- A. 1.924 A
 - B. 1.332 A
 - C. 1.184 A
 - D. 2.072 A
 - E. 1.48 A
6. A resistor made of lead has a resistance of 80 Ω at a temperature of 20 °C. The resistor is heated to a temperature of 100 °C and then connected to a 19 V battery. Calculate the current flowing through the resistor. (Lead has resistivity temperature coefficient of $3.9e-3$ /°C.)
- A. 0.181 A
 - B. 0.253 A
 - C. 0.145 A
 - D. 0.163 A
 - E. 0.235 A
7. When a certain resistor is connected to a 18.1 V battery, a current of 1.25 A flows through it. Calculate the rate at which energy is dissipated in the resistor.
- A. 29.413 W
 - B. 24.888 W
 - C. 13.575 W
 - D. 22.625 W
 - E. 27.15 W
8. The rate of dissipation of energy in a resistor connected to a 110 V battery is 100.5 W. Calculate the current through the resistor.
- A. 0.914 A
 - B. 0.64 A
 - C. 1.279 A
 - D. 1.005 A
 - E. 0.731 A

9. A 12.3Ω resistor is connected to a 8 V battery. Calculate the amount of energy dissipated in the resistor in 6 hours.
- A. $8.991e4 \text{ J}$
 - B. $14.611e4 \text{ J}$
 - C. $15.735e4 \text{ J}$
 - D. $11.239e4 \text{ J}$
 - E. $10.115e4 \text{ J}$
10. A current of 2.5 A flows through a 15.3Ω resistor connected to a battery. If electricity costs $\text{\$}12$ per kilo Watt hour, how much would it cost to run this resistor for 800 hours.
- A. $\text{\$}826.2$
 - B. $\text{\$}642.6$
 - C. $\text{\$}1285.2$
 - D. $\text{\$}918$
 - E. $\text{\$}1101.6$

qaiTEYE[®]
Challenge the way we run

**EXPERIENCE THE POWER OF
FULL ENGAGEMENT...**

.....

**RUN FASTER.
RUN LONGER..
RUN EASIER...**

**READ MORE & PRE-ORDER TODAY
WWW.GAITEYE.COM**

The advertisement features a silhouette of a runner in a red shirt and black leggings against a warm, orange-hued background. Technical diagrams, including circles and lines, are overlaid on the runner's feet, suggesting motion analysis or shoe technology. A yellow call-to-action button is located in the bottom right corner of the ad.

6 DIRECT CURRENT CIRCUITS

Your goal for this chapter is to learn about electromotive force, properties of combination of resistors and Kirchoff's rules.

Your goals for this chapter are to learn about electromotive force, combination of resistors and Kirchoff's rules.

There are two types of circuits. They are direct current (dc) circuits and alternating current (ac) circuits. A *dc circuit* is a circuit where the current or the voltage are constant in time. An *ac circuit* is a circuit where the voltage or the current vary with time typically like a sine or a cosine.

Electromotive Force of a Source

A *source* is a device that converts non electrical energy to electrical energy. Examples are a battery and a hydroelectric generator. A battery converts chemical energy to electrical energy. A hydroelectric generator converts mechanical energy to electrical energy. The following diagram shows the circuit symbol for a dc source. The longer line represents the positive terminal and the shorter line represents the negative terminal.



Figure 9.1

The amount of work done per a unit charge by a source in transporting a charge from one of its terminals to the other is called the *electromotive force* (abbreviated as emf) of the source.

$$E = W_s/q$$

Where E is the emf (in the following chapters the symbol ε will be used for emf instead of E) of a source and W_s is work done by a source in transporting a charge q from one of its terminals to the other. The unit of measurement for emf of a source is the Volt. Any source has its own internal resistance. The potential difference between the terminals of a source is less than the emf of the source, because some of its emf is dropped across its own internal resistance. If a current I is flowing across a source, the potential difference across its own resistance r is equal to Ir . Hence the potential difference (ΔV_s) across the terminal of a source is equal to the difference between its emf and the potential drop across its own internal resistance.

$$\Delta V_s = E - Ir$$

If a source is connected to an external resistance R , the potential difference across the external resistance (IR) is equal to the potential difference across the terminals of the source; that is $\Delta V_s = E - Ir = IR$. And solving for the current

$$I = E/(R + r)$$

Example: A battery of emf 20 V and internal resistance 2 Ω is connected to an external resistance of 48 Ω

- a) Calculate the current in the circuit.

Solution: $E = 20$ V; $r = 2$ Ω ; $R = 48$ Ω ; $I = ?$

$$I = E/(R + r) = 20/(48 + 2) \text{ A} = 0.4 \text{ A}$$

- b) Calculate the potential difference across the terminal of the battery.

Solution: $\Delta V_s = ?$ ΔV_s

$$\Delta V_s = E - Ir = (20 - 0.4 * 2) \text{ V} = 19.2 \text{ V}$$

- c) Calculate the potential drop across the external resistance.

Solution: $\Delta V_R = ?$

$$\Delta V_R = IR = 0.4 * 48 = 19.2 \text{ V}$$

Or

$$\Delta V_R = \Delta V_s = 19.2 \text{ V}$$

Power of a source

The *power of a source* (P_s) is the rate at which the source is converting non-electrical energy to electrical energy. In other words, it is the rate of doing work by the source in transporting charges from one of the terminals to the other; that is $P_s = W_s/t$. and since $W_s = Eq$, $P_s = E(q/t)$. But $q/t = I$. Therefore the power of a source is equal to the product of its emf and the current across it.

$$P_s = EI$$

The power delivered to the external resistance (P_R) is less than the power of the source because some of the power is dissipated in its own internal resistance. Power dissipated in its internal resistance is equal to I^2r . The power delivered to the external resistance is also equal to the power dissipated in the external resistance (I^2R).

$$P_R = EI - I^2r = I^2R$$

Example: A battery of emf 6 V and internal resistance $5\ \Omega$ is connected to resistance of $15\ \Omega$.

- a) Calculate the current in the circuit.

Solution: $E = 6\text{ V}$; $r = 5\ \Omega$; $R = 15\ \Omega$; $I = ?$

$$I = E/(R + r) = 6/(15 + 5)\ \Omega = 0.3\ \text{A}$$

- b) Calculate the power of the source.

Solution: $P_s = ?$

$$P_s = EI = 6 * 0.3\ \text{W} = 1.8\ \text{W}$$

This e-book
is made with
SetaPDF

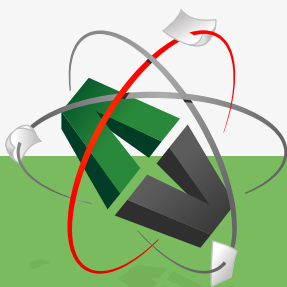

PDF components for PHP developers

www.setasign.com

c) Calculate the power delivered to the external circuit.

Solution: $P_R = ?$

$$P_R = \mathcal{E}I - I^2r = (6 * 0.05 - 0.05^2 * 5) \text{ W} = 0.2875 \text{ W}$$

d) Calculate the power dissipated in the external resistance.

Solution: The power dissipated in the external resistance is equal to the power delivered by the source to the external resistance which is 0.2875 W . Or

$$P_R = I^2R = 0.05^2 * 115 \text{ W} = 0.2875 \text{ W}$$

Combination of Resistors

An *equivalent resistance* (R_{eq}) of a combination of resistors is defined to be the single resistor that can replace the combination without changing the current and potential difference across the combination. It is equal to the ratio between the total potential difference across the combination (ΔV) and the total current (I) across the combination.

$$R_{eq} = \Delta V / I$$

Series Combination of Resistors

Series combination of resistors is combination where the resistors are connected in a single line. The following diagram shows series combination of three resistors.



Figure 9.2

Let's consider resistors R_1, R_2, R_3, \dots connected in series. Since they are connected in a single line, the currents through all of them are the same and are equal to the total current across the combination.

$$I = I_1 = I_2 = I_3 = \dots$$

Where I_1, I_2, I_3, \dots are currents across resistors R_1, R_2, R_3, \dots respectively. I is the total current across the combination. The total potential difference across the combination is equal to the sum of the potential differences across the individual resistors.

$$\Delta V = \Delta V_1 + \Delta V_2 + \Delta V_3 + \dots$$

$\Delta V_1, \Delta V_2, \Delta V_3, \dots$ are potential differences across resistors R_1, R_2, R_3, \dots respectively. ΔV is the total potential difference across the combination. Replacing each potential difference in this equation by the product of the corresponding current and resistance and noting that all the currents are equal, the following expression for the equivalent resistance of a series combination can be obtained.

$$R_{eq} = R_1 + R_2 + R_3 + \dots$$

Example: A 5Ω and a 15Ω resistors are connected in series and the connected to a potential difference of 40 V .

- a) Calculate their equivalent resistance.

Solution: $R_1 = 5 \Omega; R_2 = 15 \Omega; R_{eq} = ?$

$$R_{eq} = R_1 + R_2 = (5 + 15) \Omega = 20 \Omega$$

- b) Calculate the currents across each resistor.

Solution: $\Delta V = 40 \text{ V}; I_1 = ?; I_2 = ?$

$$I_1 = I_2 = I = \Delta V / R_{eq} = 40 / 20 \text{ A} = 2 \text{ A}$$

- c) Calculate the potential differences across each resistor.

Solution: $\Delta V_1 = ?; \Delta V_2 = ?$

$$\Delta V_1 = I_1 R_1 = 2 * 5 \text{ V} = 10 \text{ V}$$

$$\Delta V_2 = I_2 R_2 = 2 * 15 \text{ V} = 30 \text{ V}$$

Parallel Combination of Resistors

Parallel Combination of Resistors is branched combination where the resistors share the same terminals on both sides. The following diagram shows parallel combination of three resistors.

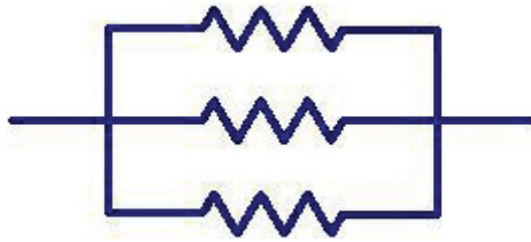
**Figure 9.3**

The potential differences across resistors combined in parallel are equal and are equal to the total potential difference across the combination because the resistors share the same terminal on both sides.

$$\Delta V = \Delta V_1 + \Delta V_2 + \Delta V_3 + \dots$$

ΔV_1 , ΔV_2 , ΔV_3 , ... are potential differences across resistors R_1 , R_2 , R_3 , ... respectively. ΔV is the total potential difference across the combination. The total current across the combination is equal to the sum of the currents across the individual resistors.

$$I = I_1 + I_2 + I_3 + \dots$$

www.sylvania.com

We do not reinvent
the wheel we reinvent
light.

Fascinating lighting offers an infinite spectrum of possibilities: Innovative technologies and new markets provide both opportunities and challenges. An environment in which your expertise is in high demand. Enjoy the supportive working atmosphere within our global group and benefit from international career paths. Implement sustainable ideas in close cooperation with other specialists and contribute to influencing our future. Come and join us in reinventing light every day.

Light is OSRAM

**OSRAM
SYLVANIA**

I_1, I_2, I_3, \dots are currents across resistors R_1, R_2, R_3, \dots respectively. I is the total current across the combination. Replacing each current in this equation by the corresponding ratio between the corresponding potential difference and resistance and noting that all the potential differences are equal, the following expression for the equivalent resistance of resistors combined in parallel can be obtained.

$$1/R_{eq} = 1/R_1 + 1/R_2 + 1/R_3 + \dots$$

If there are two resistors only, this expression can be simplified by direct addition: $1/R_{eq} = (R_1 + R_2)/(R_1 R_2)$. And an expression for the equivalent resistance of two resistors in parallel is obtained by inverting this equation.

$$R_{eq} = R_1 R_2 / (R_1 + R_2)$$

Example: A 6Ω and an 8Ω resistors are connected in parallel and then connected to a potential difference of 16 V .

- a) Calculate their equivalent resistance.

Solution: $R_1 = 6\Omega; R_2 = 8 \Omega; R_{eq} = ?$

$$R_{eq} = R_1 R_2 / (R_1 + R_2) = 6 * 8 / (6 + 8) \Omega = 3.4 \Omega$$

- b) Calculate the potential difference across each resistor.

Solution: $\Delta V = 16 \text{ V}; \Delta V_1 = ?; \Delta V_2 = ?$

$$\Delta V_1 = \Delta V_2 = \Delta V = 16 \text{ V}$$

- c) Calculate the current across each resistor.

Solution: $I_1 = ?; I_2 = ?$

$$I_1 = \Delta V_1 / R_1 = 16 / 6 \text{ A} = 2.7 \text{ A}$$

$$I_2 = \Delta V_2 / R_2 = 16 / 8 \text{ A} = 2 \text{ A}$$

Parallel-Series Combination

When a combination involves a number of series and parallel combinations, the problem can be dealt with by replacing each parallel or series combination by its equivalent resistance and repeating the process as necessary.

Example Calculate the equivalent resistance of a $10\ \Omega$, a $20\ \Omega$, a $30\ \Omega$ and a $40\ \Omega$ resistors

- a) When they are connected in series.

$$\text{Solution: } R_1 = 10\ \Omega; R_2 = 20\ \Omega; R_3 = 30\ \Omega; R_4 = 40\ \Omega; R_{\text{eq}} = ?$$

$$R_{\text{eq}} = R_1 + R_2 + R_3 + R_4 = (10 + 20 + 30 + 40)\ \Omega = 100\ \Omega$$

- b) When they are connected in parallel.

$$\text{Solution: } R_{\text{eq}} = ?$$

$$\begin{aligned} 1/R_{\text{eq}} &= 1/R_1 + 1/R_2 + 1/R_3 + 1/R_4 = (1/10 + 1/20 + 1/30 + 1/40)\ 1/\Omega \\ &= 0.21\ 1/\Omega \end{aligned}$$

$$R_{\text{eq}} = 1/0.21\ \Omega = 4.8\ \Omega$$

- c) when the parallel combination of the 10 , 20 and $30\ \Omega$ is connected in series with the $40\ \Omega$ resistor.

Solution: First the equivalent resistance of the resistors in parallel ($R_{1,2,3}$) should be obtained. Then this equivalent resistance should be combined in series with the $40\ \Omega$ resistor.

$$R_{\text{eq}} = ?$$

$$1/R_{1,2,3} = 1/R_1 + 1/R_2 + 1/R_3 = (1/10 + 1/20 + 1/30)\ 1/\Omega = 0.18\ 1/\Omega$$

$$R_{1,2,3} = 1/0.18\ \Omega = 5.6\ \Omega$$

$$R_{\text{eq}} = R_{1,2,3} + R_4 = (5.6 + 4)\ \Omega = 9.6\ \Omega$$

d) when a parallel combination of the 10 and 20Ω resistors is connected in series with a parallel combination of the 30 and 40Ω resistors.

Solution: First the equivalent resistances of the parallel combinations ($R_{1,2}$ and $R_{3,4}$). Then these equivalent resistances should be combined in series.

$$R_{eq} = ?$$

$$R_{1,2} = R_1 R_2 / (R_1 + R_2) = 10 * 20 / (10 + 20) \Omega = 6.7 \Omega$$

$$R_{3,4} = R_3 R_4 / (R_3 + R_4) = 30 * 40 / (30 + 40) \Omega = 7.7 \Omega$$

$$R_{eq} = R_{1,2} + R_{3,4} = (6.7 + 7.7) \Omega = 14.4 \Omega$$

Example: A parallel combination of a 5 and 15 ohm resistors is connected in series with a 20 ohm resistor. Then the combination is connected to a potential difference of 30 V.



Discover the truth at www.deloitte.ca/careers

Deloitte.

© Deloitte & Touche LLP and affiliated entities.



- a) Calculate the equivalent resistance of the combination.

Solution: First the equivalent resistance of the parallel combination ($R_{1,2}$) should be obtained; and then this resistance should be combined in series with the other resistor.

$$R_1 = 5 \Omega; R_2 = 15 \Omega; R_3 = 20 \Omega; R_{eq} = ?$$

$$R_{1,2} = R_1 R_2 / (R_1 + R_2) = 5 * 15 / (5 + 15) \Omega = 3.75 \Omega$$

$$R_{eq} = R_{1,2} + R_3 = (3.75 + 20) \Omega = 23.75 \Omega$$

- b) Calculate the current and potential difference across the 20 Ω resistor.

Solution: Since the 20 ohm resistor is in series with $R_{1,2}$, the current across the 20 ohm resistor should be equal to the total current.

$$\Delta V = 30 \text{ V}; I_3 = ?; \Delta V_3 = ?$$

$$I_3 = I_{1,2} = I = \Delta V / R_{eq} = 30 / 23.75 \text{ A} = 1.3 \text{ A}$$

$$\Delta V_3 = I_3 R_3 = 1.3 * 20 \text{ V} = 26 \text{ V}$$

- c) Calculate the currents and potential differences across the 5 and 15 ohm resistors.

Solution: Since they are connected in parallel their potential differences are to the potential difference across $R_{1,2}$. And since R_1 and R_2 are in series, $\Delta V_3 + \Delta V_{1,2} = \Delta V$.

$$\Delta V_1 = ?; \Delta V_2 = ?; I_1 = ?; I_2 = ?$$

$$\Delta V_1 = \Delta V_2 = \Delta V_{1,2} = \Delta V - \Delta V_3 = (30 - 26) \text{ V} = 4 \text{ V}$$

$$I_1 = \Delta V_1 / R_1 = 4 / 5 \text{ A} = 0.8 \text{ A}$$

$$I_2 = \Delta V_2 / R_2 = 4 / 15 \text{ A} = 0.27 \text{ A}$$

Practice Quiz 6.1

Choose the best answer

- Which of the following is a correct statement?
 - Emf of a source is defined to be the rate of conversion of electrical energy to non-electrical energy of the source.
 - A source is a device that converts electrical energy to non-electrical energy.
 - The rate of dissipation of electrical energy in a resistor connected to a battery is always equal to the rate of production of electrical energy in the battery.
 - A capacitor is an example of a source.
 - The potential difference across the terminals of a battery is equal to the difference between the emf of the battery and the potential drop across the internal resistance of the battery.
- Which of the following statements is correct?
 - The potential differences across resistors connected in series are equal.
 - The total current across resistors connected in series is equal to the sum of the currents across the resistors.
 - The currents across resistors connected in parallel are equal.
 - The total potential difference across resistors connected in parallel is equal to the sum of the potential differences across the resistors.
 - The currents across resistors connected in series are equal.
- A battery of emf 20 V and internal resistance 6 Ohm is connected to an external resistance of 60 Ohm . Calculate the current in the circuit.
 - 0.303 A
 - 0.273 A
 - 0.182 A
 - 0.364 A
 - 0.394 A
- When a battery of internal resistance 3 Ohm is connected to an external resistance, a current of 0.85 A flows in the circuit. If the potential difference between the terminals of the battery is measured to be 17.8 V , calculate the emf of the battery.
 - 12.21 V
 - 20.35 V
 - 18.315 V
 - 24.42 V
 - 14.245 V

5. A battery of emf 18 V and internal resistance 7 Ohm is connected to an external resistance of 55 Ohm . Calculate rate of dissipation of electrical energy in the external resistor.
- A. 6.49 W
 - B. 4.636 W
 - C. 6.027 W
 - D. 4.172 W
 - E. 5.563 W
6. When a battery of internal resistance 4 Ohm is connected to an external resistance of 19 Ohm , a current of 0.95 A flows in the circuit. Calculate the rate of production of electrical energy in the battery.
- A. 26.985 W
 - B. 22.833 W
 - C. 29.06 W
 - D. 20.758 W
 - E. 16.606 W

SIMPLY CLEVER

ŠKODA



We will turn your CV into
an opportunity of a lifetime



Do you like cars? Would you like to be a part of a successful brand?
We will appreciate and reward both your enthusiasm and talent.
Send us your CV. You will be surprised where it can take you.

Send us your CV on
www.employerforlife.com



7. Calculate the equivalent resistance of a parallel combination of a(n) $5\ \Omega$, a(n) $3\ \Omega$ and a(n) $16\ \Omega$ resistor.
- A. $2.014\ \Omega$
 - B. $1.007\ \Omega$
 - C. $2.182\ \Omega$
 - D. $1.678\ \Omega$
 - E. $1.51\ \Omega$
8. Calculate the equivalent resistance of the series combination of a(n) $5\ \Omega$ resistor and a parallel combination of a(n) $6\ \Omega$ and a(n) $7\ \Omega$ resistors.
- A. $8.231\ \Omega$
 - B. $4.938\ \Omega$
 - C. $9.054\ \Omega$
 - D. $10.7\ \Omega$
 - E. $9.877\ \Omega$
9. A(n) $20\ \Omega$ and a(n) $11\ \Omega$ resistors are connected in parallel and then connected to a $16\ \text{V}$ battery. Calculate the potential difference across the $20\ \Omega$ resistor.
- A. $12\ \text{V}$
 - B. $19\ \text{V}$
 - C. $17\ \text{V}$
 - D. $16\ \text{V}$
 - E. $14\ \text{V}$
10. A(n) $20\ \Omega$ and a(n) $17\ \Omega$ resistors are connected in parallel and then connected to a(n) $7\ \text{V}$ battery. Calculate the current through the $20\ \Omega$ resistor.
- A. $0.35\ \text{A}$
 - B. $0.315\ \text{A}$
 - C. $0.245\ \text{A}$
 - D. $0.28\ \text{A}$
 - E. $0.49\ \text{A}$
11. A(n) $18\ \Omega$ and a(n) $17\ \Omega$ resistors are connected in series and then connected to a(n) $14\ \text{V}$ battery. Calculate the current through the $18\ \Omega$ resistor.
- A. $0.28\ \text{A}$
 - B. $0.56\ \text{A}$
 - C. $0.44\ \text{A}$
 - D. $0.48\ \text{A}$
 - E. $0.4\ \text{A}$

12. A(n) 18 Ohm and a(n) 21 Ohm resistors are connected in series and then connected to a 15 V battery. Calculate the potential difference across the 18 Ohm resistor.
- A. 5.538 V
 - B. 9.692 V
 - C. 6.923 V
 - D. 9 V
 - E. 7.615 V
13. The parallel combination of a(n) 2 Ohm and a 15 Ohm resistors is connected in series with a(n) 13 Ohm resistor. And then the combination is connected to a potential difference of 45 V. Calculate the current through the 13 Ohm resistor.
- A. 4.267 A
 - B. 3.048 A
 - C. 3.962 A
 - D. 2.743 A
 - E. 2.438 A
14. The parallel combination of a(n) 23 Ohm and a 27 Ohm resistors is connected in series with a(n) 28 Ohm resistor. And then the combination is connected to a potential difference of 45 V. Calculate the potential difference across the 28 Ohm resistor.
- A. 28.055 V
 - B. 21.821 V
 - C. 37.407 V
 - D. 18.704 V
 - E. 31.173 V

Kirchoff's Rules

Kirchoff's rules are rules used to solve complex circuits. There are two of them. They are known as the junction rule and the loop rule.

Kirchoff's junction rule states that the sum of all the currents in a junction is zero.

$$\sum I = I_1 \pm I_2 \pm I_3 \dots = 0$$

A *junction* is a point in a circuit where two or more wires meet. Currents headed towards the junction are taken to be positive whereas currents going away from the junction are taken to be negative.

Kirchoff's loop rule states that the sum of all potential differences in a loop is zero.

$$\sum \Delta V = \Delta V_1 + \Delta V_2 + \Delta V_3 + \dots = 0$$

In going around a loop, to apply the loop rule a transversing direction (clockwise or counter clockwise) should be chosen. The potential difference across the terminals of a battery is taken to be positive if the battery is transversed from its negative to its positive terminal and negative if transversed from its positive terminal to its negative terminal. The potential difference across the terminals of a resistor is taken to be negative if the resistor is transversed in the direction of the current and positive if transversed opposite to the direction of the current.

I joined MITAS because
I wanted **real responsibility**

The Graduate Programme
for Engineers and Geoscientists
www.discovermitas.com



Month 16

I was a construction
supervisor in
the North Sea
advising and
helping foremen
solve problems

Real work
International opportunities
Three work placements



 **MAERSK**

Applying Kirchoff's Rules

In applying Kirchoff's rules, the following procedures may be followed.

1. For each wire in the circuit, assign a variable to the current and choose a direction for the current arbitrarily. If after solving the problem a current turns out to be positive, the actual direction of the current is the same as the chosen direction; and if the current turns out to be negative, the actual direction of the current is opposite to the chosen direction.
2. Assign transversing direction to each simple loop in the circuit. A *simple loop* is a non-intersecting loop or a loop that is not divided into more loops. This is the direction to be followed while applying Kirchoff's loop rule.
3. If there are n junctions in a circuit, apply the Kirchoff's junction rule only to $n - 1$ of them, because the n^{th} junction will not result in an independent equation. Current variables should be treated as positives. Negatives should be introduced outside the variable. For example if a current I is going away from a junction, in applying the junction rule, it should appear as $-I$.
4. Apply the loop rule to all the simple loops of the circuit. A starting point should be chosen for each simple loop and the loop should be transversed in the direction of the chosen transversing direction to add all the potential differences in the simple loop. Variables for unknown emfs should be treated as positives. Negatives should be introduced outside the variable. For example if the unknown emf is represented by E and the battery is transversed from its positive to its negative terminal, in applying the loop rule, it should appear as $-E$.
5. Solve the resulting system of linear equations.

Example: Consider the circuit shown below. Resistors A and C have resistances of 20 and 60 ohm respectively. Batteries B and D have emfs of 8 and 4 V respectively. Determine the value and the direction of the current in the circuit.

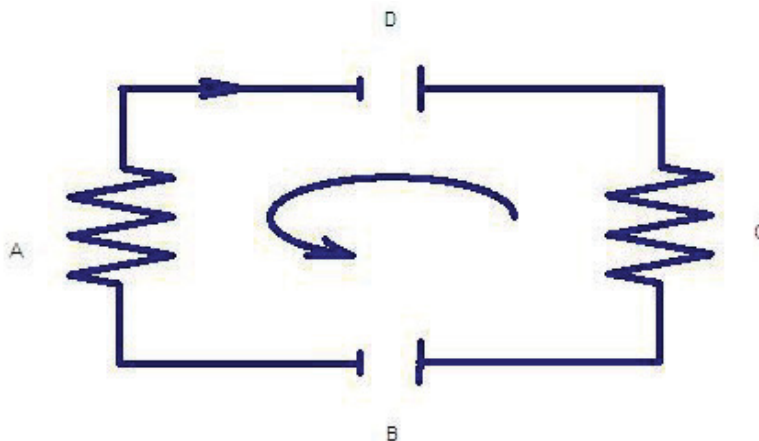

Figure 9.4

Solution: The circuit has only one simple loop and one wire. Thus the circuit has only one current. First an arbitrary direction for the current and a transversing direction should be chosen. These arbitrary directions are already indicated in the circuit above. This circuit does not have a junction and thus no need to apply the junction rule. Only the loop rule need to be applied. The potential differences across both resistors should be taken to be positive because they are being transverse opposite to the direction of the current. The potential difference across the terminals of battery B should be taken to be positive because the battery is being transversed from its negative to its positive terminal. The potential difference across the terminals of battery D should be taken to be negative because the battery is being transversed from its positive to its negative terminal. Let the starting point be the lower right corner of the circuit.

$$R_A = 20 \Omega; R_C = 60 \Omega; E_B = 8 \text{ V}; E_D = 4 \text{ V}; I = ?$$

$$\sum \Delta V = \Delta V_1 + \Delta V_2 + \Delta V_3 + \dots = 0$$

$$IR_C - E_D + IR_A + E_B = 0$$

$$I(60 \Omega) - 4 \text{ V} + I(20 \Omega) + 8 \text{ V} = 0$$

$$I(80 \Omega) = -4 \text{ V}$$

$$I = -4/80 \text{ A} = -0.05 \text{ A}$$

Since the current turned out to be negative the actual direction should be opposite to the assigned direction (clockwise). The actual direction of the current is counter clockwise.

Example: Consider the circuit shown below. Resistors A, C and D have resistances of 10, 20 and 30 ohm respectively. Batteries B, E and F have emfs of 6, 12 and 20 V. Calculate all the currents in the circuit.

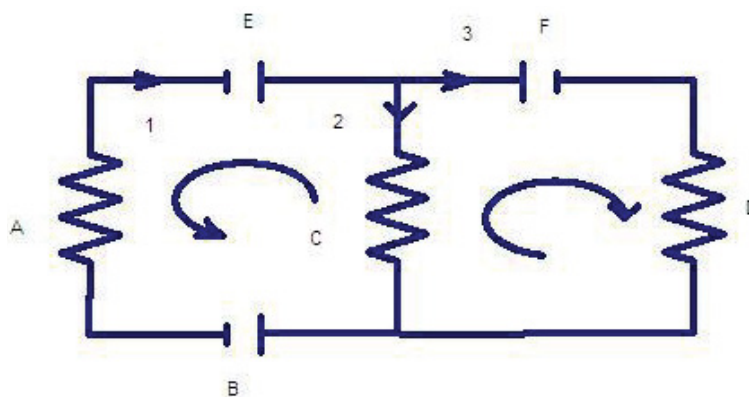

Figure 9.5

Solution: The circuit has two simple loops (loops ABCEA and CDFC) and two junctions. Thus the loop rule should be applied to both simple loops and the junction rule should be applied to one of the junctions. The circuit has three different wires marked as 1, 2 and 3. Thus there are three different currents (I_1 , I_2 and I_3) in the circuit. The arbitrary directions of the currents and the arbitrary transversing directions of the simple loops are already indicated in the circuit.

$$R_A = 10 \Omega; R_C = 20 \Omega; R_D = 30 \Omega; E_B = 6 \text{ V}; E_E = 12 \text{ V}; E_F = 20 \text{ V}; I_1 = ?; I_2 = ?; I_3 = ?$$

The junction rule should be applied to one of the junctions say the upper junction. I_1 should be taken to be positive because it is directed towards the junction. I_2 and I_3 should be multiplied by -1 because they are directed away from the junction.

$$I_1 - I_2 - I_3 = 0$$

$$I_3 = I_1 - I_2 \dots \dots (1)$$

In the equations to follow I_3 will be replaced by $I_1 - I_2$ to get two equations in two variables.

ie business school

#1 EUROPEAN BUSINESS SCHOOL
FINANCIAL TIMES 2013

#gobeyond

MASTER IN MANAGEMENT

Because achieving your dreams is your greatest challenge. IE Business School's Master in Management taught in English, Spanish or bilingually, trains young high performance professionals at the beginning of their career through an innovative and stimulating program that will help them reach their full potential.

- Choose your area of specialization.
- Customize your master through the different options offered.
- Global Immersion Weeks in locations such as London, Silicon Valley or Shanghai.

Because you change, we change with you.

www.ie.edu/master-management | mim.admissions@ie.edu | f t in YouTube

Next the loop rule should be applied to one of the simple loops, say the simple loop on the left (loop ABCEA). The potential differences across resistors A and C should be taken to be positive because the resistors are being transversed opposite to the directions of the assigned currents. The potential difference across the terminals of battery B should be taken to be positive because it is being transversed from its negative to its positive terminal. The potential difference across the terminals of battery E should be taken to be negative because it is being transversed from its positive to its negative terminal. Starting at the left lower corner of the circuit

$$E_B + I_2 R_C - E_E + I_1 R_A = 0$$

$$6 \text{ V} + I_2 (20 \Omega) - 12 \text{ V} + I_1 (10 \Omega) = 0$$

$$10I_1 + 20I_2 = 6 \text{ A}$$

$$I_2 = (6 \text{ A} - 10I_1)/20 = 0.3 \text{ A} - 0.5I_1 \dots (2)$$

Next the loop rule should be applied to the second simple loop (loop CDFC). The potential difference across resistor D is taken to be negative because it is being transversed in the direction of the current. The potential difference across resistor C is taken to be positive because it is being transversed opposite to the direction of the current. The potential difference between the terminals of battery F is taken to be negative because it is being transversed from its positive to its negative terminal. Starting from the lower right corner

$$I_2 R_C - 20 \text{ V} - I_3 R_D = 0$$

$$I_2 (20 \Omega) - 20 \text{ V} - I_3 (30 \Omega) = 0$$

$$20I_2 - 30I_3 = 20 \text{ A}$$

Substituting for I_3 from equation (1) ($I_3 = I_1 - I_2$)

$$20I_2 - 30(I_1 - I_2) = 20 \text{ A}$$

$$-30I_1 + 50I_2 = 20 \text{ A}$$

Substituting for I_2 from equation (2) ($I_2 = 0.3 \text{ A} - 0.5I_1$)

$$-30I_1 + 50(0.3 \text{ A} - 0.5I_1) = 20 \text{ A}$$

$$-55I_1 = 5 \text{ A}$$

$$I_1 = -5/55 \text{ A} = -0.09 \text{ A}$$

The negative sign indicates that the direction of I_1 is opposite to the chosen direction. Current I_2 can be obtained from equation (2).

$$I_2 = 0.3 \text{ A} - 0.5I_1 = (0.3 - 0.5 * -0.09) \text{ A} = 0.345 \text{ A}$$

Since the current is positive, the direction of I_2 is the same as the assigned direction. I_3 can be obtained from equation (1).

$$I_3 = I_1 - I_2 = (-0.09 - 0.345) \text{ A} = -0.435 \text{ A}$$

The direction of I_3 is opposite to the assigned direction because it is negative.

Example: Consider Figure 4 again. Resistors A and C have resistances of 5 and 15 ohm. Battery B has an emf of 6 V. There is a current of 2 A in the circuit in the indicated direction (clockwise). Calculate the emf of battery D.

Solution: The unknown emf can be solved by applying the loop rule. The polarity of the unknown emf (the order of its negative and positive terminals) is also unknown. The unknown emf can be assigned an arbitrary polarity. If, after solving the problem, the emf turns out to be positive, then the actual polarity is the same as the chosen polarity; and if it turns out to be negative, the actual polarity is opposite to the chosen polarity. In the diagram, an arbitrary polarity has already been assigned to the unknown emf. The potential differences across both resistors are positive because they are being transversed opposite to the direction of the current. The potential difference across battery B should be positive because it is being transversed from its negative to its positive terminal. The potential difference across battery D should be negative because it is being transversed from its positive to its negative terminal.

$$I = 2 \text{ A}; R_A = 5 \Omega; R_C = 15 \Omega; E_B = 6 \text{ V}; E_D = ?$$

Starting at the lower left corner

$$E_B + IR_C - E_D + IR_A = 0$$

$$6\text{ V} + 2 * 15\text{ V} - E_D + 2 * 5\text{ V} = 0$$

$$E_D = 46\text{ V}$$

Since E_D turned out to be positive, its actual polarity is the same as the chosen polarity.

A battery connected to a series combination of a resistor and a capacitor

Consider a battery of emf ε connected to a series combination of a resistor of resistance R and a capacitor of capacitance C . Applying Kirchhoff's loop rule to this simple loop

$$\varepsilon - \frac{q}{C} - IR = 0$$

"I studied English for 16 years but...
...I finally learned to speak it in just six lessons"

Jane, Chinese architect

ENGLISH OUT THERE

Click to hear me talking before and after my unique course download

q stands for the instantaneous charge of the capacitor. But $I = \frac{dq}{dt}$. Therefore $\varepsilon - \frac{q}{C} - \frac{dq}{dt}R = 0$ and rearranging the equation becomes

$$\frac{dq}{dt} + \frac{1}{RC}q - \frac{\varepsilon}{R} = 0$$

This differential equation can be integrated using the method of substitution: $\frac{dq}{dt} = \frac{\varepsilon}{R} - \frac{1}{RC}q$

which implies $\frac{dq}{\frac{\varepsilon}{R} - \frac{1}{RC}q} = dt$. The initial charge on the capacitor is zero. Thus this equation

can be integrated as $\int_0^{q(t)} \frac{dq}{\frac{\varepsilon}{R} - \frac{1}{RC}q} = \int_0^t dt = t$. This integral can be integrated by the method of

substitution. Let $u = \frac{\varepsilon}{R} - \frac{1}{RC}q$. Then $u(t=0) = \frac{\varepsilon}{R}$ and $dq = -RCdu$ and the integral becomes

$$-RC \int_{\frac{\varepsilon}{R}}^{\frac{\varepsilon}{R} - \frac{1}{RC}q} \frac{du}{u} = -RC \ln \left(\frac{\frac{\varepsilon}{R} - \frac{1}{RC}q}{\frac{\varepsilon}{R}} \right) = t. \text{ Therefore } \varepsilon - \frac{q}{C} = \varepsilon e^{-\frac{1}{RC}t} \text{ and rearranging}$$

$$q(t) = \varepsilon C \left(1 - e^{-\frac{1}{RC}t} \right)$$

As the time approaches infinity, the charge approaches the value εC which is the maximum charge accumulated by the capacitor. The current in the circuit as a function of time can be obtained by taking the derivative of the charge with respect to time.

$$I(t) = \frac{\varepsilon}{R} e^{-\frac{1}{RC}t}$$

The current has its maximum value at $t = 0$ which is equal to $\frac{\varepsilon}{R}$. The current goes to zero as time approaches infinity. The expression $\frac{1}{RC}$ is called the time constant of the circuit. It determines how fast the capacitor reaches its maximum charge or how fast the current goes to zero.

A Charged Capacitor connected to a Resistor

Consider a capacitor of capacitance C and charge Q_0 connected to a resistor of resistance R . Using Kirchhoff's rules and transversing in the direction of the current as shown.

Applying Kirchhoff's rules the equation $-\frac{q}{C} - IR = 0$ can be obtained. Replacing I by $\frac{dq}{dt}$ and rearranging the equation $\frac{dq}{q} = -\frac{1}{RC} dt$ can be obtained. The charge as a function of time can be obtained by integrating this equation: $\int_{Q_0}^{q(t)} \frac{dq}{q} = -\frac{1}{RC} \int_0^t dt = -\frac{t}{RC}$. This implies that $\left(\frac{q}{Q_0}\right) = e^{-\frac{t}{RC}}$. Therefore the charge varies as a function of time as

$$q(t) = Q_0 e^{-\frac{1}{RC}t}$$

As time approaches infinity, the charge in the capacitor approaches zero. The expression $\frac{1}{RC}$ is called the time constant of the circuit. It determines how fast the charge goes to zero. The current as a function of time is obtained by taking the derivative of the charge.

$$I(t) = -\frac{Q_0}{RC} e^{-\frac{1}{RC}t}$$

The current has its maximum value at $t = 0$ which is equal to $\frac{Q_0}{RC} = \frac{Q_0/C}{R} = \frac{\Delta V_0}{R}$ where ΔV_0 is the initial potential difference across the capacitor or resistor. The current approaches zero as the time approaches infinity.

Example: A 5 mF capacitor is connected to a 10V battery. Then it is disconnected from the battery and then connect to a 2 kΩ resistor. How long would the capacitor to lose half of its charge.

Solution:

$$C = 5 \times 10^{-3} \text{ F}; R = 2 \times 10^3 \text{ } \Omega; q = \frac{Q_0}{2}; t = ?$$

$$q(t) = Q_0 e^{-\frac{1}{RC}t} = \frac{Q_0}{2}$$

$$e^{\frac{1}{RC}t} = 2$$

$$\frac{1}{RC}t = \ln(2)$$

$$t = RC \ln(2) = 2 \times 10^3 \times 5 \times 10^{-3} \ln(2) \text{ s} = 6.93 \text{ s}$$

Practice Quiz 6.2

Choose the best answer

1. Which of the following is a correct statement?
 - A. The sum of all currents at a junction of a circuit may or may not be equal to zero
 - B. The sum of all potential differences in a complete loop is equal to the sum of the potential differences across the batteries in the loop.
 - C. If a circuit has n simple loops, Kirchoff's loop rule should be applied to n of them.
 - D. All of the other choices are not correct statements.
 - E. If a circuit has n junctions, Kirchoff's junction rule should be applied to n of them.

Excellent Economics and Business programmes at:



university of
 groningen



“The perfect start
of a successful,
international career.”

CLICK HERE
to discover why both socially
and academically the University
of Groningen is one of the best
places for a student to be

www.rug.nl/feb/education

2. Which of the following is a correct statement?
- A. In applying Kirchoff's junction rule, current in a junction is taken to be positive if it is directed away from the junction.
 - B. In applying Kirchoff's loop rule, the potential difference across a battery is always taken to be positive.
 - C. In applying Kirchoff's loop rule, the potential difference across a resistor is taken to be negative if it is transversed in the direction of the current.
 - D. In applying Kirchoff's loop rule, the potential difference across a resistor is always taken to be negative.
 - E. In applying Kirchoff's loop rule, the potential difference across a battery is taken to be negative, if it is transversed from the negative to the positive terminal
3. This problem is based on Figure 9.4. Resistors A and C have resistances of $13\ \Omega$ and $10\ \Omega$ respectively. Batteries B and D have emfs of $26\ \text{V}$ and $12\ \text{V}$ respectively. Determine the value and the direction of the current in the circuit.
- A. $0.609\ \text{A}$ clockwise
 - B. $0.67\ \text{A}$ counter clockwise
 - C. $0.67\ \text{A}$ clockwise
 - D. $0.487\ \text{A}$ counter clockwise
 - E. $0.609\ \text{A}$ counter clockwise
4. This problem is based on Figure 9.4. The current in the circuit is $0.513\ \text{A}$ in the direction indicated (clockwise). Resistors A and C have resistances $13\ \Omega$ and $18\ \Omega$ respectively. Battery D has an emf of $30\ \text{V}$. Determine the value and polarity of the emf of battery B .
- A. $14.097\ \text{V}$; polarity same as assumed polarity
 - B. $15.507\ \text{V}$; polarity opposite to assumed polarity
 - C. $16.916\ \text{V}$; polarity opposite to assumed polarity
 - D. $15.507\ \text{V}$; polarity same as assumed polarity
 - E. $14.097\ \text{V}$; polarity opposite to assumed polarity
5. This problem is based on Figure 9.5. Which of the following represents Kirchoff's junction rule as applied to this circuit? (Wires are represented by numbers 1 , 2 , and 3 .)
- A. $I_1 + I_2 + I_3 = I$
 - B. $I_1 + I_2 + I_3 = 0$
 - C. $I_1 - I_2 + I_3 = 0$
 - D. $I_1 + I_2 - I_3 = 0$
 - E. $I_1 - I_2 - I_3 = 0$

6. This problem is based on Figure 9.5. The current in wire 1 (left wire) is 5 A in the direction shown. The current in wire 2 (middle wire) is 10 A in the direction shown. Calculate the current in wire 3 (right wire).
- A. -15 A
 - B. 15 A
 - C. -5 A
 - D. 5 A
 - E. 0 A
7. This problem is based on Figure 9.5. Resistors *A*, *C* and *D* have resistances of 11 Ohm, 6.5 Ohm, and 13.3 Ohm respectively. Batteries *B*, *E* and *F* have emfs of 2.7 V, 15 V and 10 V respectively. Which of the following equations represents Kirchoff's loop rule as applied to the left simple loop (starting from the lower left corner).
- A. $-2.7 + 6.5 * I_2 + 15 + 11 * I_1 = 0$
 - B. $2.7 + 6.5 * I_2 - 15 - 11 * I_1 = 0$
 - C. $2.7 + 6.5 * I_2 - 15 + 11 * I_1 = 0$
 - D. $2.7 - 6.5 * I_2 - 15 - 11 * I_1 = 0$
 - E. $-2.7 + 6.5 * I_2 - 15 + 11 * I_1 = 0$
8. This problem is based on Figure 9.5. Resistors *A*, *C* and *D* have resistances of 17 Ohm, 6.5 Ohm, and 16.3 Ohm respectively. Batteries *B*, *E* and *F* have emfs of 8.7 V, 9 V and 16 V respectively. Which of the following equations represents Kirchoff's loop rule as applied to the right simple loop (starting from the lower right corner).
- A. $-6.5 * I_2 - 16 + 16.3 * I_3 = 0$
 - B. $-6.5 * I_2 - 16 - 16.3 * I_3 = 0$
 - C. $-6.5 * I_2 + 16 - 16.3 * I_3 = 0$
 - D. $6.5 * I_2 - 16 - 16.3 * I_3 = 0$
 - E. $6.5 * I_2 - 16 + 16.3 * I_3 = 0$
9. This problem is based on Figure 9.5. Resistors *A*, *C* and *D* have resistances of 5 Ohm, 9.5 Ohm, and 13.3 Ohm respectively. Batteries *B*, *E* and *F* have emfs of 8.7 V, 30 V and 27.5 V respectively. Calculate the current through resistor *C*. wire.
- A. 1.226 A
 - B. 1.05 A
 - C. 1.751 A
 - D. 1.576 A
 - E. 1.401 A

10. This problem is based on Figure 9.5. Resistors A , C and D have resistances of $11.2\ \Omega$, $12.5\ \Omega$, and $24.3\ \Omega$ respectively. The currents through resistors A and C are $0.7\ \text{A}$ and $0.2\ \text{A}$ respectively. Battery B has an emf of $2.7\ \text{V}$. The emfs of batteries E and F respectively are.

- A. $14.344\ \text{V}$ and $-10.615\ \text{V}$
- B. $10.432\ \text{V}$ and $-7.72\ \text{V}$
- C. $13.04\ \text{V}$ and $-10.615\ \text{V}$
- D. $14.344\ \text{V}$ and $-9.65\ \text{V}$
- E. $13.04\ \text{V}$ and $-9.65\ \text{V}$

American online LIGS University

is currently enrolling in the
Interactive Online **BBA, MBA, MSc,**
DBA and PhD programs:

- ▶ enroll **by September 30th, 2014** and
- ▶ **save up to 16%** on the tuition!
- ▶ pay in 10 installments / 2 years
- ▶ Interactive Online education
- ▶ visit www.ligsuniversity.com to
find out more!

Note: LIGS University is not accredited by any
nationally recognized accrediting agency listed
by the US Secretary of Education.
More info [here](#).



7 MAGNETIC FIELDS

Your goal for this chapter is to learn about the nature of magnetic forces, magnetic forces on a charge moving in a magnetic field and current carrying wires, magnetic torques on current carrying loops, and electromagnetic forces.

Magnetic Force is a force that exists between current carrying objects. Unlike electric force whose source is excess charges, the source of magnetic force is excess current. *Magnetic Field* is a field used to represent magnetic force. The SI unit of magnetic field is the Tesla abbreviated as T. *Magnetic Field Lines* are lines used to represent magnetic field graphically. The lines are drawn in such a way that a) the number of lines per a unit perpendicular area (density of lines) is proportional to the magnitude of the field and b) the line tangent to the curve at a given point has the same line of action as the magnetic field. To distinguish between the two possible directions of the tangent line, an arrow is placed on the curves. Unlike electric field lines (which originate in a positive charge and sink in a negative charge), magnetic field lines form complete loops.

Permanent Magnets: The origin of the magnetic field due to permanent magnets is the motion of electrons around the nucleus (which constitutes current). For most elements the currents due to the electrons of an atom cancel each and thus most elements do not have magnetic properties. But for some elements such as nickel, iron and cobalt, the currents due to the electrons do not cancel each other. As a result the atoms of these elements have net magnetic properties.

Normally, a sample of a magnetic material such as iron do not have magnetic properties even though their atoms do. The reason is that the atomic magnets are randomly distributed and they cancel each other. But if a magnetic material is placed in an external magnetic field, the atomic magnets are aligned in the direction of the field and the magnetic material acquires a net magnetic property becoming a magnet.

Permanent magnets of certain shapes (such as a rectangle) have two locations where the magnetic field is the strongest. These locations are called the poles of the magnet. These poles are identified as the North and South Poles of the magnet. If a magnet is free to rotate across a pivot, one of its ends will point towards the north pole of earth. This is because earth has its own magnet. The pole that points towards the North Pole of earth is called the north pole of the magnet and the other pole is called the south pole of the magnet. Experiment shows that similar poles repel and opposite poles attract. Since the north pole of a magnet points towards the north pole of the earth its follows that the south pole of earth's magnet is located on the geographic north pole of earth.

Magnetic field lines come out of the North Pole and come into the South Pole.

Magnetic Force on a Charge Moving in a Magnetic Field

Magnetic force (\vec{F}_B) acting on a charge (q) moving with a velocity (\vec{v}) is equal to the product of its charge and the cross product between its velocity and the magnetic field.

$$\vec{F}_B = q\vec{v} \times \vec{B}$$

If the angle between \vec{v} and \vec{B} is θ , then the magnitude of $\vec{v} \times \vec{B}$ is $vB \sin \theta$ where v and B are the magnitudes of the velocity and magnetic field respectively. Therefore the magnitude of the magnetic force is (F_B) is given by

$$F_B = |q|vB \sin \theta$$

If \vec{v} and \vec{B} are expressed in the \hat{i} - \hat{j} notation, then evaluating $\vec{F}_B = q\vec{v} \times \vec{B}$ will give both the magnitude and direction of the magnetic force. Another alternative is to calculate the magnitude from $F_B = |q|vB \sin \theta$ and obtaining the direction from the screw or right hand rule. The direction of the magnetic force is always perpendicular to the plane determined by the velocity and magnetic field vectors. To distinguish between the two possible directions which are perpendicularly out of the plane (graphically represented by a dot (\cdot)) and perpendicularly into the plane (graphically represented by a cross (\times)), the screw rule or the right hand rule can be used. (Mathematically, if a coordinate system where the xy -plane lies in the plane determined by the velocity and the field is used, then the direction perpendicularly out is represented by the unit vector \hat{k} and the direction perpendicularly into is represented by the unit vector $-\hat{k}$.)

The Screw Rule

First connect the velocity vector and the magnetic field vector tail to tail. Then place the screw perpendicularly at their tails, and rotate the screw from the velocity vector towards the field vector. Then, if the charge is positive the direction of movement of the screw gives direction of the magnetic force and if the charge is negative the direction of the magnetic force is opposite to the direction of movement of the screw. A screw goes in if turned clockwise and goes out if turned counter clockwise.

The right hand rule

First arrange the index finger and the middle finger of the right hand in such a way that they are perpendicular to thumb. Align the index finger in the direction of the velocity and the middle finger in the direction of the field; then if the charge is positive, direction of thumb gives direction of magnetic force and if the charge is negative the direction of the magnetic force is opposite to that of the thumb.

Example: A 4 mC charge is going north-east in a uniform magnetic field of strength 2 T directed towards east with a speed of 600 m/s. Determine the magnitude and direction of the magnetic force acting on the charge.

Solution: Let's use the screw rule to determine the direction. If a screw is placed in direction perpendicular to both the field and the velocity and is turned from the velocity vector (north-east) towards the field vector (east), the screw goes in. Since the charge is positive, the direction of the magnetic force must be perpendicularly in (x).

$$q = 4 \times 10^{-3} \text{ C}; v = 600 \text{ m/s}; B = 2 \text{ T}; \theta = 45^\circ; F_B = ?$$

$$F_B = |q|vB \sin(\theta) = 4 \times 10^{-3} \times 600 \times 2 \sin(45^\circ) \text{ N} = 3.4 \text{ N}$$

$$F_B = 3.4 \text{ N perpendicularly in } (\times)$$

.....Alcatel-Lucent 

www.alcatel-lucent.com/careers

What if you could build your future and create the future?

One generation's transformation is the next's status quo. In the near future, people may soon think it's strange that devices ever had to be "plugged in." To obtain that status, there needs to be "The Shift".

Or alternatively,

$$\vec{B} = 2\hat{i} \text{ T}$$

$$\vec{v} = (600 \cos(45^\circ)\hat{i} + 600 \sin(45^\circ)\hat{j}) \text{ m/s} = (424\hat{i} + 424\hat{j}) \text{ m/s}$$

$$\vec{F}_B = q\vec{v} \times \vec{B} = 4 \times 10^{-3} (424\hat{i} + 424\hat{j}) \times (2\hat{i}) \text{ N} = -3.4\hat{k} \text{ N}$$

Example: A 6 n C is moving west with a speed of $3e6 \text{ m/s}$ in a region where the magnetic field is directed perpendicularly into the plane of the paper (x). The strength of the magnetic field is 6 mT . Determine the magnitude and direction of the magnetic field acting on the charge.

Solution: Let's use the right hand rule to determine the direction. If the index finger and the middle finger of the right hand are arranged in such a way that the index finger is directed in the direction of the velocity (west) and the middle finger is directed in the direction of the field (perpendicularly in), the thumb points south (down the paper) when arranged to be perpendicular to both fingers. Since the charge is negative, the direction of the magnetic force is opposite to that of the thumb. Thus the direction of the magnetic force is north (towards the top of the paper). The angle between the velocity and the field is 90° because they are perpendicular to each other.

$$q = -6 \times 10^{-9} \text{ C}; v = 3 \times 10^6 \text{ m/s}; B = 6 \times 10^{-3} \text{ T}; \theta = 90^\circ; F_B = ?$$

$$F_B = |q|vB \sin(\theta) = 6 \times 10^{-9} \times 3 \times 10^6 \times 6 \times 10^{-3} \sin(90^\circ) \text{ N} = 1.08 \times 10^{-4} \text{ N}$$

$$\vec{F}_B = 1.08 \times 10^{-4} \text{ N south}$$

Or alternatively,

$$\vec{B} = -6 \times 10^{-3} \hat{k} \text{ T}$$

$$\vec{v} = -3 \times 10^6 \hat{i}$$

$$\vec{F}_B = q\vec{v} \times \vec{B} = -6 \times 10^{-9} (-6 \times 10^{-3} \hat{k}) \times (-3 \times 10^6 \hat{i}) \text{ N} = -1.08 \times 10^{-4} \text{ N}$$

Magnetic Force on a current carrying wire placed on a magnetic field

Take a small element of the wire $d\vec{\ell}$ that contains charge dq . Suppose the charge dq is moving with a velocity \vec{v} , then the magnetic force acting on this element is $d\vec{F}_B = dq(\vec{v} \times \vec{B})$. But $\vec{v} = \frac{d\vec{\ell}}{dt}$. Therefore $d\vec{F}_B = dq\left(\frac{d\vec{\ell}}{dt} \times \vec{B}\right) = \frac{dq}{dt}(d\vec{\ell} \times \vec{B})$. But $\frac{dq}{dt} = |I|$ which is the current and the force acting on this small element is $d\vec{F}_B = |I|(d\vec{\ell} \times \vec{B})$. The total force (\vec{F}_B) on the wire is obtained by integrating over the whole wire: $\vec{F}_B = \int d\vec{F}_B = \int |I|(d\vec{\ell} \times \vec{B}) = |I|\left(\int d\vec{\ell}\right) \times \vec{B}$. But $\int d\vec{\ell} = \Delta\vec{\ell}$ $\Delta\vec{\ell}$ is the vector connecting the ends of the wire (irrespective of the shape of the wire) and its direction is the direction of the current (Remember conventionally the direction of current is the direction of movement of positive charges. If \vec{r}_i and \vec{r}_f are the position vectors of the end points of the wire and the current is directed from \vec{r}_i to \vec{r}_f , then $\Delta\vec{\ell} = \vec{r}_f - \vec{r}_i$). Therefore the force acting on a current carrying wire placed in a magnetic field is given by

$$\vec{F}_B = |I| \Delta\vec{\ell} \times \vec{B}$$

For a closed loop, $\Delta\vec{\ell} = \vec{0}$ and it follows that the net force acting on a current carrying loop is zero.

If $\Delta\vec{\ell}$ and \vec{B} are expressed in the \hat{i} - \hat{j} notation then the magnitude and direction can be obtained directly from $\vec{F}_B = I \Delta\vec{\ell} \times \vec{B}$. Alternatively, the magnitude can be obtained from $F_B = I \Delta\ell B \sin\theta$ where $\Delta\ell$ is the magnitude of $\Delta\vec{\ell}$ (not the length of the wire), θ is the angle between $\Delta\vec{\ell}$ and \vec{B} ; and the direction can be obtained from the screw rule or the right hand rule. In using the screw rule, the screw is rotated from $\Delta\vec{\ell}$ towards \vec{B} and in using the right hand rule $\Delta\vec{\ell}$ is represented by the index finger and the field is represented by the middle finger.

Example: A wire of length 1.5 m carrying a current of 3 A to the right is placed in a uniform magnetic field of strength 5 T directed to the left. Determine the magnitude and direction of the magnetic force acting on the wire.

Solution: The angle between the wire and the field is 180° because the current and the field have opposite directions.

$$I = 3 \text{ A}; \Delta\ell = 1.5 \text{ m}; B = 5 \text{ T}; \theta = 180^\circ; F_B = ?$$

$$F_B = |I| \Delta\ell B \sin(\theta) = 3 \times 1.5 \times 5 \sin(180^\circ) = 0$$

No need to specify direction since the force is zero.

$$\vec{F}_B = 0$$

Or alternatively,

$$\Delta\ell = 1.5\hat{i} \text{ m}$$

$$\vec{B} = -5\hat{i} \text{ T}$$

$$\vec{F}_B = |I| \Delta\vec{\ell} \times \vec{B} = 3(1.5\hat{i}) \times (-5\hat{i}) = 0$$



In the past four years we have drilled

81,000 km

That's more than **twice** around the world.

Who are we?
We are the world's leading oilfield services company. Working globally—often in remote and challenging locations—we invent, design, engineer, manufacture, apply, and maintain technology to help customers find and produce oil and gas safely.

Who are we looking for?
We offer countless opportunities in the following domains:

- Engineering, Research, and Operations
- Geoscience and Petrotechnical
- Commercial and Business

If you are a self-motivated graduate looking for a dynamic career, apply to join our team.

careers.slb.com

What will you be?

Schlumberger

Example: A wire of length 2 m carrying a current of 10 A towards south (towards the bottom of the paper) is placed in a 7 T magnetic field whose direction is perpendicularly out of the paper (\cdot). Determine the magnitude and direction of the magnetic force acting on the wire.

Solution: Let's use the screw rule to determine the direction. The plane determined by the wire (south) and the field (perpendicularly out) is the plane perpendicular to the plane of this paper. When the screw is put perpendicular to this plane from the right side of the plane and rotated from the wire (south) towards the field, it goes in towards west. Therefore the direction of the magnetic force acting on the wire is west. The angle between the wire and the field is 90° .

$$I = 10 \text{ A}; \Delta l = 2 \text{ m}; B = 7 \text{ T}; \theta = 90^\circ; F_B = ?$$

$$F_B = |I| \Delta l B \sin(\theta) = 10 \times 2 \times 7 \text{ N} = 140 \text{ N}$$

$$\vec{F}_B = 140 \text{ N west}$$

Or alternatively,

$$\Delta \vec{l} = -2 \hat{j} \text{ m}$$

$$\vec{B} = 7 \hat{k} \text{ T}$$

$$\vec{F}_B = |I| \Delta \vec{l} \times \vec{B} = 10(-2 \hat{j}) \times (7 \hat{k}) = -140 \hat{i}$$

Example: The end points of an irregularly shaped wire are located at the points A(1, 2) m and B(4, 6) m. The length of the wire is 10 m. It carries a current of 2 A from point A towards point B. Calculate the magnetic force acting on the wire when it is placed in a 0.005 T magnetic field directed towards west.

Solution:

$$I = 2 \text{ A}; \vec{B} = -0.005 \hat{i} \text{ T}; \vec{r}_i = (1, 2) \text{ m}; \vec{r}_f = (4, 6) \text{ m}; \vec{F}_B = ?$$

$$\Delta \vec{l} = \vec{r}_f - \vec{r}_i = (4 \hat{i} + 6 \hat{j}) \text{ m} - (\hat{i} + 2 \hat{j}) \text{ m} = (3 \hat{i} + 4 \hat{j}) \text{ m}$$

$$\vec{F}_B = |I| \Delta \vec{l} \times \vec{B} = 2(3 \hat{i} + 4 \hat{j}) \times (-0.005 \hat{i}) \text{ N} = 0.04 \hat{k} \text{ N}$$

Practice Quiz 7.1

Choose the best answer

- Which of the following is a correct statement?
 - Magnetic field lines come out of the South Pole and go into the North Pole.
 - The cause of magnetic force is excess charge.
 - The SI unit of measurement for magnetic field is Newton / Ampere.
 - The cause of the magnetic field due to permanent magnets is earth's magnetic field.
 - Magnetic field lines form a complete loops.
- Which of the following is a correct statement?
 - When a magnet is free to rotate across a pivot, its North Pole points towards the geographic South Pole of earth.
 - The magnetic force on a charge moving in a magnetic field is proportional to the sine of the angle between the field and the velocity.
 - The magnetic torque acting on a current carrying loop placed in a magnetic field is inversely proportional to the area of the loop.
 - Similar poles attract opposite poles repel.
 - The magnetic force on a current carrying straight wire placed in a magnetic field is inversely proportional to the strength of the field.
- A magnetic force of 641 N acts on a positively charged object when it moves north with a speed of 140 m/s in a field of strength 0.13 T directed towards east. Calculate its charge.
 - 42.264 C
 - 31.698 C
 - 35.22 C
 - 0 C
 - 24.654 C
- A force of 765 N acts on a 0.17 C charge when it moves towards south in a magnetic field of strength 4 T directed 50° west of south. How fast is it going?
 - 1174.867 m/s
 - 1615.442 m/s
 - 1468.583 m/s
 - 2056.016 m/s
 - 1909.158 m/s

5. Determine the direction of the magnetic force on a positive charge going east in a region where the magnetic field is directed north.
- A. perpendicularly out
 - B. east
 - C. perpendicularly in
 - D. south
 - E. west
6. A $1.4e-3$ C charge is moving with a velocity of $(2.5e3 \mathbf{i} + 3.4e3 \mathbf{j} + 1.4e3 \mathbf{k})$ m/s in a region where there is a magnetic field of $(8.2 \mathbf{i} + 9.3 \mathbf{j})$ T. Calculate the magnitude of the magnetic force acting on the charge.
- A. 27.666 N
 - B. 25.151 N
 - C. 17.606 N
 - D. 15.091 N
 - E. 20.121 N



Maastricht University

Leading in Learning!

**Join the best at
the Maastricht University
School of Business and
Economics!**

Top master's programmes

- 33rd place Financial Times worldwide ranking: MSc International Business
- 1st place: MSc International Business
- 1st place: MSc Financial Economics
- 2nd place: MSc Management of Learning
- 2nd place: MSc Economics
- 2nd place: MSc Econometrics and Operations Research
- 2nd place: MSc Global Supply Chain Management and Change

Sources: Keuzegids Master ranking 2013; Elsevier 'Beste Studies' ranking 2012; Financial Times Global Masters in Management ranking 2012

Maastricht University is the best specialist university in the Netherlands (Elsevier)

**Visit us and find out why we are the best!
Master's Open Day: 22 February 2014**

www.mastersopenday.nl



7. Determine the direction of the magnetic force acting on a straight wire carrying current towards south placed in a region where the magnetic field is directed east.
- perpendicularly out
 - west
 - north
 - east
 - perpendicularly in
8. Calculate the magnitude of the magnetic force acting on a straight wire of length 2.25 m carrying a current of 7.2 A directed towards east placed in a magnetic field of strength 0.32 T directed towards east.
- 5.184 N
 - 5.702 N
 - 6.739 N
 - 0 N
 - 4.147 N
9. A 1.2 N magnetic force acts on a straight wire of length 1.5 m carrying a current of 1.2 A directed towards east when it is placed in region where there is a magnetic field whose direction is 35° north of east. Calculate the strength of the magnetic field.
- 1.627 T
 - 1.046 T
 - 1.395 T
 - 1.162 T
 - 1.511 T
10. A straight wire that extends from the origin to the point P(2.5, 4.5, 2.5) m carries a current of 6.7 A directed from the origin to point P. If there is a magnetic field of $(6.7 \mathbf{i} + 8.2 \mathbf{j})$ T, calculate the magnetic force acting on the wire.
- $(-137.35 \mathbf{i} + 134.67 \mathbf{j} + -45.259 \mathbf{k})$ N
 - $(-151.085 \mathbf{i} + 134.67 \mathbf{j} + -45.259 \mathbf{k})$ N
 - $(-137.35 \mathbf{i} + 112.225 \mathbf{j} + -64.655 \mathbf{k})$ N
 - $(-151.085 \mathbf{i} + 134.67 \mathbf{j} + -64.655 \mathbf{k})$ N
 - $(-96.145 \mathbf{i} + 112.225 \mathbf{j} + -90.517 \mathbf{k})$ N

11. A wire that extends straight from the origin to point A $(0, 0.53)$ m and then straight to point B $(0.65, 0.53)$ m is carrying a current of 1.4 A directed from the origin to point B. If there is a magnetic field of strength 6.4 T in the region whose direction is perpendicularly outward, calculate the direction of the magnetic force exerted on the wire.
- A. 45.726°
 B. 50.807°
 C. -45.726°
 D. -50.807°
 E. -40.645°

Magnetic Torque on a current carrying loop placed in a magnetic field

Consider a small element $d\vec{\ell}$ of a current carrying loop placed in a magnetic field. The magnetic force acting on this element is given by $d\vec{F}_B = I d\vec{\ell} \times \vec{B}$. The magnetic torque acting on this element about the axis of rotation shown is $d\vec{\tau} = \vec{r}_\perp \times d\vec{F}_B$ where \vec{r}_\perp is a radial position vector of $d\vec{\ell}$ with respect to the axis of rotation. Therefore $d\vec{\tau} = \vec{r}_\perp \times (I d\vec{\ell} \times \vec{B})$. The total torque on the loop is obtained by integrating $d\vec{\tau}$ over the entire loop: $\vec{\tau} = \int d\vec{\tau} = \int [\vec{r}_\perp \times (I d\vec{\ell} \times \vec{B})]$. Assuming I and \vec{B} are constants, they can be taken out of the integration: $\vec{\tau} = I \int [\vec{r}_\perp \times d\vec{\ell}] \times \vec{B}$. The expression $\vec{r}_\perp \times d\vec{\ell}$ is equal to the area of the parallelogram determined by $\vec{r}_\perp \times d\vec{\ell}$; that is $\vec{r}_\perp \times d\vec{\ell} = d\vec{A}$ and $\vec{\tau} = I \left\{ \int d\vec{A} \right\} \times \vec{B}$. But $\int d\vec{A} = \vec{A}$ which is the area of the loop. Therefore the magnetic torque acting on a current carrying loop placed in a magnetic field is given as

$$\vec{\tau} = I (\vec{A} \times \vec{B})$$

The current I is taken to be positive if it is flowing counterclockwise and negative if it is flowing clockwise. Remember the direction of area is perpendicular to the plane of the loop. Thumb gives the direction of area when right hand fingers are wrapped around the loop in a counterclockwise direction. If the angle formed between \vec{A} and \vec{B} is θ , then the magnitude of the torque is given by

$$\tau = |I| AB \sin \theta$$

The maximum value of the torque occurs when $\theta = 90^\circ$; that is when \vec{A} is perpendicular to \vec{B} or when the field is parallel to the plane of the loop. The direction of torque and the direction of rotation (that is either clockwise or counterclockwise) is determined by the right hand rule. When thumb is aligned in the direction of the torque, the direction of fingers represents direction of rotation. For example when thumb point up, fingers will be wrapped in a counterclockwise direction.

If \vec{A} and \vec{B} are expressed in the $\hat{i} - \hat{j}$ notation, then the magnitude and direction of the torque can be obtained directly from $\vec{\tau} = I(\vec{A} \times \vec{B})$. Alternatively, the magnitude can be obtained from $\tau = |I|AB \sin \theta$ and the direction can be obtained either from the screw rule or the right hand rule.

In using the screw rule, the screw should be turned from \vec{A} towards \vec{B} . The direction of movement of the screw will be in the direction of torque if the current is counterclockwise and opposite to the direction of torque if the current is clockwise.

In using the right hand rule, \vec{A} is represented by the index finger and \vec{B} is represented by the middle finger. The direction of torque will be in the direction of thumb if the current is counterclockwise and opposite to the direction of the thumb if the current is clockwise.



> Apply now

REDEFINE YOUR FUTURE
**AXA GLOBAL GRADUATE
PROGRAM 2015**

redefining / standards 

agence.cdg - © Photonostop

Example: A circular loop of radius 2 m is placed on the xy -plane in a region where there is magnetic field of strength 10 T east. The loop is carrying a current of 4A in a counter clockwise direction.

a) Determine the magnetic torque acting on the loop.

Solution: The current should be taken to be positive because it is flowing in a counterclockwise direction.

$$I = 2 \text{ A}; \vec{B} = 10\hat{i} \text{ T}; r = 2 \text{ m}; \vec{\tau} = ?$$

$$\vec{A} = \pi r^2 \hat{k} = 2^2 \pi \hat{k} \text{ m}^2 = 4\pi \hat{k} \text{ m}^2$$

$$\vec{\tau} = I(\vec{A} \times \vec{B}) = 4(4\pi \hat{k}) \times (10\hat{i}) \text{ Nm} = 160\pi \hat{j} \text{ Nm}$$

That is the direction is north. Alternatively, the magnitude can be determined from $\tau = |I|AB\sin\theta$ (with $\theta = 90^\circ$) and then the direction can be determined using the screw or the right hand rule.

b) Is the loop rotating clockwise or counterclockwise?

Solution: With thumb in the direction of torque (north) fingers are wrapped in a counterclockwise direction. Thus, the loop will be rotating in a counterclockwise direction,

Magnetic Moment

Magnetic moment ($\vec{\mu}$) of a current carrying loop is defined to be the product of the current in the loop and the area of the loop.

$$\vec{\mu} = I\vec{A}$$

If the current is in a counterclockwise direction (the current is positive) then $\vec{\mu}$ has the same direction as the area; and if the current is clockwise (the current is negative) the direction of $\vec{\mu}$ is opposite to that of \vec{A} . In other words, the direction of $\vec{\mu}$ is related with the direction of the current by the right hand rule. When fingers are wrapped in the direction of the current, thumb will give the direction of the magnetic moment. The unit of measurement of magnetic moment is Am^2 . The torque acting on a current carrying loop placed in a magnetic field can now be written in terms of magnetic moment as

$$\vec{\tau} = \vec{\mu} \times \vec{B}$$

Example: A circular loop of radius 2 m on the xy -plane carries a current of 0.5 A in a clockwise direction. Determine its magnetic moment.

Solution: The current should be taken to be negative because it is flowing in a clockwise direction. The direction of the area is perpendicularly out or \hat{k} .

$$I = -0.5 \text{ A}; r = 2 \text{ m}; \vec{\mu} = ?$$

$$\vec{A} = \pi r^2 \hat{k} = 4\pi \hat{k}$$

$$\vec{\mu} = I\vec{A} = -0.5 \times 4\pi \hat{k} \text{ Am}^2 = -2\pi \hat{k} \text{ Am}^2$$

Magnetic Potential Energy

Consider a current carrying loop placed in a magnetic field in such a way that the angle between its magnetic moment and field is different from zero or 180° . There will be a net torque acting on it according to the equation $\tau = |I|AB \sin \theta$. If the loop is let go from this orientation, it will rotate because of the torque acting on it. In other words, this orientation is a source for rotational kinetic energy. This indicates that there is a magnetic potential energy associated with current carrying loops placed in a magnetic field.

A loop placed in a magnetic field rotates because there is a tangential magnetic force on the loop. The work done by this tangential force as the loop is displaced (rotated) by a small displacement $d\vec{r}$, is $dW = \vec{F}_t \cdot d\vec{r}$. Therefore the change in potential energy associated with this work is $dU = -dW = -\vec{F}_t \cdot d\vec{r}$. Now consider a loop placed in a magnetic field in such a way that its magnetic moment is parallel to the magnetic field. At this position the torque acting on the loop is zero (because $\theta = 0$). Magnetic torque is a restoring force. If this loop is rotated counterclockwise (clockwise) the magnetic torque will be clockwise (counterclockwise). In other words, the tangential magnetic force is opposite to the displacement: $dW = -F_t |d\vec{r}|$. Since the displacement is rotational, $|d\vec{r}| = ds = r_\perp d\theta$ where r_\perp represents the radius of rotation. Therefore $dW = -F_t r_\perp d\theta$. But $F_t r_\perp = \tau$ and $dU = -dW = \tau d\theta$. The total change in potential energy is obtained by integration: $U = \int \tau d\theta + C$. But $\tau = \mu B \sin \theta$ and $U = \int \mu B \sin \theta d\theta = -\mu B \cos \theta + C$. It is easier to choose the reference point to be the orientation where $\cos \theta = 0$. Therefore, let $U\left(\theta = \frac{\pi}{2}\right) = 0$. With this choice of reference point, $C = 0$ and $U = -\mu B \cos \theta$. The magnetic potential energy can also be written as a dot product as

$$U = -\vec{\mu} \cdot \vec{B}$$

The minimum potential energy occurs when $\vec{\mu}$ and \vec{B} are parallel ($\theta = 0$): $u|_{\theta=0} = -\mu B$

The maximum potential energy occurs when $\vec{\mu}$ & \vec{B} are opposite ($\theta = 180^\circ$): $u|_{\theta=180^\circ} = \mu B$

These are orientations where the torque is zero. The former is a stable equilibrium orientation and the latter is unstable equilibrium orientation. The reference point ($\theta = \frac{\pi}{2}$) is the orientation where the maximum torque occurs. Even though this formula is obtained for orientations, it is generally valid. For example suppose the magnetic field changes along the x -axis. Then there will be a linear force along the x -axis because $F_x = -\frac{\partial u}{\partial x} = \vec{\mu} \cdot \frac{\partial \vec{B}}{\partial x}$. This explains why iron is attracted (or repelled) by a magnet. The force is the result of the fact that the magnetic field gets stronger and stronger as the magnet is approached.

Example: A loop of radius 2 m carrying current of 3 A in a clockwise direction is placed in a region where there is a magnetic field of strength 0.4 T directed perpendicularly out of the plane of the loop. Calculate the magnetic potential energy stored by the loop.



Empowering People. Improving Business.

BI Norwegian Business School is one of Europe's largest business schools welcoming more than 20,000 students. Our programmes provide a stimulating and multi-cultural learning environment with an international outlook ultimately providing students with professional skills to meet the increasing needs of businesses.

BI offers four different two-year, full-time Master of Science (MSc) programmes that are taught entirely in English and have been designed to provide professional skills to meet the increasing need of businesses. The MSc programmes provide a stimulating and multi-cultural learning environment to give you the best platform to launch into your career.

- MSc in Business
- MSc in Financial Economics
- MSc in Strategic Marketing Management
- MSc in Leadership and Organisational Psychology

BI NORWEGIAN BUSINESS SCHOOL

EFMD
EQUIS
ACCREDITED

www.bi.edu/master

Solution: Let the plane of the loop be the xy -plane. The current should be negative because it is flowing in a clockwise direction.

$$I = -3 \text{ A}; \vec{B} = 0.4\hat{k} \text{ T}; r = 2 \text{ m}; U = ?$$

$$\vec{A} = \pi r^2 \hat{k} = 2^2 \pi \hat{k} \text{ m}^2 = 4\pi \hat{k} \text{ m}^2$$

$$\vec{\mu} = I\vec{A} = -3 \times 4\pi \hat{k} \text{ Am}^2 = -12\pi \hat{k} \text{ Am}^2$$

$$U = -\vec{\mu} \cdot \vec{B} = -(-12\pi \hat{k}) \cdot (0.4\hat{k}) \text{ J} = 4.8 \text{ J}$$

Mass Spectrometer

Mass Spectrometer is a device used to separate a mixture of charges according to their masses (assuming they all have the same charge). Consider a particle of mass m and charge q propelled to a magnetic field B perpendicularly with a speed v . As the charge enters the field it will be acted upon by a magnetic force $F_B = |q|vB\sin\theta$; but $\theta = 90^\circ$ and $F_B = |q|vB$. Since this force is perpendicular to the trajectory (velocity) of the particle, its effect is only to change direction and not magnitude. Such force is called a centripetal force and the resulting trajectory is circular. Let the radius of this trajectory be R . Centripetal force is related with the speed of the object according to the equation $F_C = \frac{mv^2}{R}$. Therefore $F_B = F_C = \frac{mv^2}{R} = |q|vB$ and the radius of the circular trajectory is given as

$$R = \frac{mv}{|q|B}$$

This equation shows that the radius of the trajectory depends on the mass of the particle. Thus if a mixture of charges of different masses is propelled to the field, the particles will have different trajectories according to their masses resulting in the separation of the particles according to their masses.

Example: An electron is propelled perpendicularly into a magnetic field of strength 2 mT with a speed of 10^6 m/s. How long does it take to make one complete revolution?

Solution: Let the period be T .

$$q = -1.6 \times 10^{-19} \text{ C}; m = 9.1 \times 10^{-31} \text{ kg}; B = 0.002 \text{ T}; v = 10^6 \text{ m/s}; T = ?$$

$$R = \frac{mv}{|q|B}$$

$$T = \frac{2\pi R}{v} = \frac{2\pi}{v} \frac{mv}{|q|B} = \frac{2\pi m}{|q|B} = \frac{2\pi \times 9.1 \times 10^{-31}}{1.6 \times 10^{-19} \times 2 \times 10^{-3}} \text{ s} = 1.78 \times 10^{-9} \text{ s}$$

Electromagnetic force on a charge

A charge in a region where there are both electric and magnetic fields, is subjected to both electrical and magnetic forces. The electrical force is $q\vec{E}$ where \vec{E} stands for electric field; and the magnetic force is $q\vec{v} \times \vec{B}$ where \vec{v} stands for the velocity of the charge and \vec{B} stands for the field. The net electromagnetic force is the sum of these two forces:

$$\vec{F}_{em} = q\vec{E} + q\vec{v} \times \vec{B}$$

Example: A 2 C charge is moving in a region where there is electric field directed towards north and a magnetic field that penetrates the paper perpendicularly inward. The magnitude of the electric field is 200 N/C and the magnitude of the magnetic field is 5 T. Calculate the electromagnetic force acting on the charge when it is moving towards east with a speed of 100 m/s.

Solution: Let the plane of the paper be the xy-plane.

$$q = 2 \text{ C}; \vec{E} = 200\hat{j} \text{ N/C}; \vec{B} = -5\hat{k} \text{ T}; \vec{v} = 100\hat{i} \text{ m/s}; \vec{F}_{em} = ?$$

$$\vec{F}_{em} = q\vec{E} + q\vec{v} \times \vec{B} = \left[2(200\hat{j}) + 2(100\hat{i}) \times (5(-\hat{k})) \right] \text{ N} = (600\hat{j} + 1500\hat{j}) \text{ N} = 2100\hat{j} \text{ N}$$

Example: A charge is moving towards east in a straight line without being deflected in a region where there is a 2000 N/C electric field directed towards north and a 0.005 T magnetic field whose direction is perpendicularly out of the plane determined by the velocity and the electric field. Calculate the speed of the charge.

Solution: The net electromagnetic force acting on the charge should be zero because it is moving in a straight line with a constant speed.

$$\vec{E} = 2000\hat{j} \text{ N/C}; \vec{B} = 0.005\hat{k} \text{ T}; \vec{F}_{em} = 0; \vec{v} = v\hat{i}$$

$$\vec{F}_{em} = q\vec{E} + q\vec{v} \times \vec{B} = 0$$

$$\vec{E} + \vec{v} \times \vec{B} = 0 = 2000\hat{j} + (v\hat{i}) \times (0.005\hat{k})$$

$$2000\hat{j} - 0.005v\hat{j} = 0$$

$$2000 = 0.005v$$

$$v = 4 \times 10^7 \text{ m/s}$$

Cyclotron

A cyclotron is a device used to accelerate charges to a high energy. It essentially consists of two half cylinders connected to an alternating potential difference placed in a magnetic field parallel to one axis of the cylinders. A charge is propelled perpendicular to the field. The charge will move in a circular path because of the magnetic force. Every time it goes from one of the half cylinders to the other it will be accelerated because of the potential difference between the half cylinders ($\Delta U = q\Delta v$). As the velocity increases because of the potential difference, the radius of revolution increases. Eventually, the radius of revolution is increased to the outer radius of the cyclotron. Let the outer radius of the cyclotron be R , then $\frac{mv^2}{R} = qvB$ and the speed of the charge by the time it leaves the cyclotron is given by

$$v = \frac{qRB}{m}$$

Thus, the energy of the charge by the time it leaves the cyclotron is $E = \frac{1}{2}mv^2 = \frac{1}{2}m\left(\frac{qRB}{m}\right)^2$ or

$$E = \frac{1}{2m}q^2R^2B^2$$

A common unit of energy for atomic particles is the electron Volt abbreviation as eV.

Need help with your dissertation?

Get in-depth feedback & advice from experts in your topic area. Find out what you can do to improve the quality of your dissertation!

Get Help Now



Go to www.helpmyassignment.co.uk for more info



An electron-volt is defined to be the energy needed to accelerate an electron through a potential difference of one volt. Therefore Electron volt = $q\Delta V = (1.6 \times 10^{-19} \text{ C})(1 \text{ V}) = 1.6 \times 10^{-19} \text{ J}$

$$1 \text{ eV} = 1.6 \times 10^{-19} \text{ J}$$

The Hall Effect

Hall Effect refers to the fact that when a current carrying conductor is placed in a magnetic field perpendicular to the current, electric field (potential difference) is developed in a direction perpendicular to both the current and the magnetic field. Consider the rectangular conductor shown which carries current in the positive y direction ($\vec{v}_d = v_d \hat{j}$) and placed in a region where there is magnetic field whose direction is along the positive z -axis ($\vec{B} = B\hat{k}$)

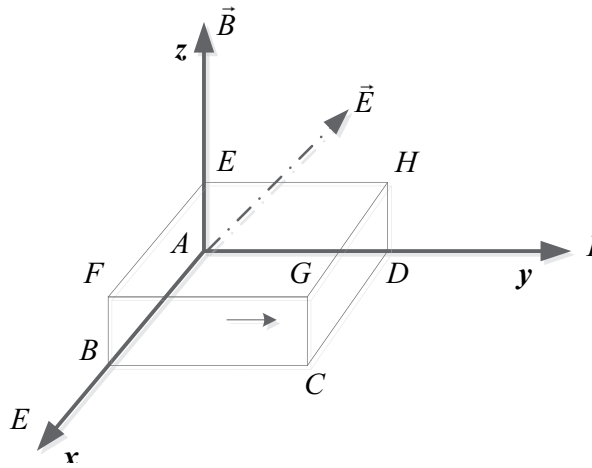

The charges carrying the current will be subjected to a magnetic force according to the equation $F_B = q\vec{v}_d \times \vec{B}$ where \vec{v}_d is the drift velocity of the charges. But $\vec{v}_d = v_d \hat{j}$ and $\vec{B} = B\hat{k}$. Therefore $\vec{F}_B = q(v_d \hat{j} \times B\hat{k}) = qv_d B(\hat{j} \times \hat{k}) = qv_d B\hat{i}$. Therefore the charges (assumed to be positive conventionally) will be pushed towards the surface $BCGFB$. As a result the face $BCGFB$ will be positively charged and the opposite face $ADHEA$ will be negatively charged because of the deficiency of positive charges. As a result there will be an electric field directed from the positively charged face $BCGFB$ to the negatively charged face $ADHEA$. That is $\vec{E} = -E\hat{i}$. Therefore the current carrier charges are subjected to both electric force and magnetic force. The electric force ($\vec{F}_E = -qE\hat{i}$) is opposed to the magnetic force ($F_B = qv_d B\hat{i}$). The buildup of the charges on the faces $BCGFB$ & $ADHEA$ can continue only until the magnetic force is balanced by the electric force. The balancing electric field is called the Hall electric field (denoted by E_H). When $E = E_H$; the sum of the electric force and magnetic force should be zero: $\vec{F}_E + \vec{F}_B = -qE_H\hat{i} + qv_d B\hat{i} = 0$ which implies

$$E_H = v_d B$$

The potential difference between the faces $BCGFB$ & $ADHEA$ is equal to the product of the electric field E_H and the perpendicular distance between these faces (\overline{AB}). Let $\overline{AB} = d$. Therefore the Hall potential difference (ΔV_H) is given by $\Delta V_H = E_H d = v_d B d$. The Hall Effect is often used to measure an unknown magnetic field $B = \frac{\Delta V_H}{v_d d}$. But $v_d = \frac{I}{nqA}$ where n is concentration of charges and A is the cross-sectional area of the face perpendicular to the current: $A = \overline{AB} \times \overline{AE}$. Let $\overline{AE} = t$, then $A = td$. With $v_d = \frac{I}{nqt d}$, the expression for the magnetic field becomes

$$B = \frac{\Delta V_H}{v_d d} = \frac{nqt \Delta V_H}{I}$$

Example: Consider the rectangular block shown in the above diagram. Suppose the block is made up of copper and is carrying current of 2 A in the direction shown (y-axis). And suppose there is a magnetic field along the positive z-axis as shown whose magnitude is unknown. The dimensions of the rectangular block are $\overline{AE} = 0.02$ m, $\overline{AB} = 0.04$ m and $\overline{AD} = 0.06$ m.

Calculate the magnitude of the magnetic field, if the Hall potential difference between the faces $ABCD$ & $ADHEA$ is measured to be 5 nV. (Atomic mass density of Cu are 63.5 u and 8920 kg/m³ respectively)

Solution: n (concentration of charges) can be obtained as the ratio between Avogadro number and the volume of one gram molecular weight of copper (Cu has only one electron per atom). The volume of one gram molecular (V_g) weight can be obtained as the ratio of gram molecular weight to the density.

$$\Delta V_H = 5 \times 10^{-9} \text{ V}; d = \overline{AB} = 0.04 \text{ m}; \overline{AE} = 0.02 \text{ m}; I = 2 \text{ A}; M_g = 0.0635 \text{ kg}; \rho = 8920 \text{ kg/m}^3; B = ?$$

$$V_g = \frac{M_g}{\rho}$$

$$n = \frac{N_A}{V_g} = \frac{N_A}{\frac{M_g}{\rho}} = \frac{6.02 \times 10^{23}}{\frac{63.5 \times 10^{-3}}{8920}} \text{ 1/m}^3 = 8.46 \times 10^{28} \text{ 1/m}^3$$

$$v_d = \frac{I}{nqA} = \frac{I}{nq(\overline{AB} \cdot \overline{AE})} = \frac{2}{(8.46 \times 10^{28})(1.6 \times 10^{-19})[(0.04)(0.02)]} \text{ m/s} = 1.85 \times 10^{-7} \text{ m/s}$$

$$B = \frac{\Delta V_H}{v_d d} = \frac{5 \times 10^{-9}}{(1.85 \times 10^{-7})(0.04)} \text{ T} = 0.68 \text{ T}$$

Practice Quiz 7.2

Choose the best answer

1. A rectangular wire of sides 0.1 m and 1.8 m that carries a current of 6.45 is placed in a region where there is a magnetic field of strength 4.5 T which is perpendicular to the plane of the loop. Calculate the magnitude of the magnetic torque acting on the wire.
A. 6.269 N m
B. 3.657 N m
C. 4.702 N m
D. 5.225 N m
E. 0 N m



Brain power

By 2020, wind could provide one-tenth of our planet's electricity needs. Already today, SKF's innovative know-how is crucial to running a large proportion of the world's wind turbines.

Up to 25 % of the generating costs relate to maintenance. These can be reduced dramatically thanks to our systems for on-line condition monitoring and automatic lubrication. We help make it more economical to create cleaner, cheaper energy out of thin air.

By sharing our experience, expertise, and creativity, industries can boost performance beyond expectations. Therefore we need the best employees who can meet this challenge!

The Power of Knowledge Engineering

Plug into The Power of Knowledge Engineering.
Visit us at www.skf.com/knowledge



2. A circular loop carrying a current in a counter clockwise direction is placed in a magnetic field directed towards west. If the plane of the loop is parallel to the field, determine the direction of the magnetic torque acting on the loop.
- A. perpendicularly in
 - B. north
 - C. perpendicularly out
 - D. south
 - E. west
3. A circular loop carrying a current in a clockwise direction is placed in a magnetic field directed towards north. If the plane of the loop is parallel to the field, determine the direction of the magnetic torque acting on the loop.
- A. east
 - B. perpendicularly out
 - C. west
 - D. perpendicularly in
 - E. south
4. Determine the magnetic moment of a circular coil in the xy -plane of radius 0.35 m carrying a current of 1.6 A in a counter clockwise direction.
- A. $-0.554 \mathbf{k}$ A m²
 - B. $-0.739 \mathbf{k}$ A m²
 - C. $-0.616 \mathbf{k}$ A m²
 - D. $0.616 \mathbf{k}$ A m²
 - E. $0.554 \mathbf{k}$ A m²
5. A proton is propelled east with a speed of $7.2e6$ m/s to a region where there is a magnetic field of strength 4 T directed perpendicularly out of the paper. Calculate the period of the resulting circular motion of the proton. A proton has a mass of $1.67e-27$ kg and a charge of $1.6e-19$ C.
- A. $16.395e-9$ s
 - B. $9.837e-9$ s
 - C. $19.674e-9$ s
 - D. $11.477e-9$ s
 - E. $14.756e-9$ s

6. The electric field and the magnetic field in a certain region are $1.4e3$ N/C west and 6.9 T perpendicularly in respectively. Calculate the direction of the electromagnetic force acting on a $5.1e-3$ C charge at the time its velocity is $0.9e3$ m/s east.
- A. 143.786°
B. 61.623°
C. 102.705°
D. 82.164°
E. 133.516°
7. In a certain region, there is an electric field whose direction is north and a magnetic field of $2.7e-3$ T perpendicularly out. What should the magnitude of the electric field be if a proton is to travel towards east through the fields without being deflected with a speed of $1.6e6$ m/s.
- A. $2.592e3$ N/C
B. $4.32e3$ N/C
C. $5.184e3$ N/C
D. $3.024e3$ N/C
E. $6.048e3$ N/C
8. The magnetic field used in a cyclotron has a strength of 1.6 T. If the energy of a proton by the time it leaves the cyclotron is $6.4e7$ eV, calculate the outer radius of the cyclotron (A proton has a charge of $1.6e-19$ C and a mass of $1.67e-27$ kg).
- A. 0.722 m
B. 0.433 m
C. 0.795 m
D. 0.867 m
E. 0.939 m
9. Consider a rectangular block of metal with faces parallel to the xy-plane, xz-plane and xy-plane that carries current in the negative y direction. Determine the direction of the Hall electric field when placed in a magnetic field whose direction is along the positive z-axis.
- A. $-j$
B. $-k$
C. $-i$
D. j
E. i

10. Consider a rectangular block of copper whose corners are located at $(0, 0, 0)$, $(1.2e-2, 0, 0)$ m, $(1.2e-2, 3.1e-2, 0)$ m, $(0, 3.1e-2, 0)$ m, $(0, 0, 4.4e-4)$ m, $(1.2e-2, 0, 4.4e-4)$ m, $(1.2e-2, 3.1e-2, 4.4e-4)$ m and $(0, 3.1, 4.4e-4)$ m. The block is carrying a current of 2.8 A in the direction of the positive x-axis. There is a magnetic field of strength 1.6 T, directed along the positive z-axis. Calculate the Hall electric field. Copper has gram molecular weight of 63.5 g and a density of 8920 kg/m³.
- A. $0.34e-4$ N/C
B. $0.243e-4$ N/C
C. $0.316e-4$ N/C
D. $0.291e-4$ N/C
E. $0.218e-4$ N/C



What do you want to do?

No matter what you want out of your future career, an employer with a broad range of operations in a load of countries will always be the ticket. Working within the Volvo Group means more than 100,000 friends and colleagues in more than 185 countries all over the world. We offer graduates great career opportunities – check out the Career section at our web site www.volvogroup.com. We look forward to getting to know you!

VOLVO
AB Volvo (publ)
www.volvogroup.com

VOLVO TRUCKS | RENAULT TRUCKS | MACK TRUCKS | VOLVO BUSES | VOLVO CONSTRUCTION EQUIPMENT | VOLVO PENTA | VOLVO AERO | VOLVO IT
VOLVO FINANCIAL SERVICES | VOLVO 3P | VOLVO POWERTRAIN | VOLVO PARTS | VOLVO TECHNOLOGY | VOLVO LOGISTICS | BUSINESS AREA ASIA

8 SOURCES OF THE MAGNETIC FIELD

Magnetic Field due to a Moving Charge

The magnitude of the magnetic field due to a moving charge at a certain point P depends on three factors. It is proportional to the charge (q). It is inversely proportional to the square of the distance (r_p) between the charge and the point. And it is proportional to the component of the velocity perpendicular (v_{\perp}) to the position vector (\vec{r}_p) of the point with respect to the charge. The component of the velocity parallel to the position vector of the point with respect to the charge does not contribute to the magnetic field. Therefore the magnitude of the magnetic field may be given as $B = \frac{\mu_0 q v_{\perp}}{4\pi r_p^2}$. The constant μ_0 is called magnetic permeability of vacuum.

$$\mu_0 = 4\pi \times 10^{-7} \text{ Tm / A}$$

The direction of the magnetic field is perpendicular to the plane determined by the velocity vector (\vec{v}) and the position vector of the point with respect to the charge, \vec{r}_p . In other words its direction is the same as the direction of the cross product between \vec{v} and \vec{r}_p . Therefore the unit vector in the direction of the field may be written as $\hat{e}_B = \frac{\vec{v} \times \vec{r}_p}{|\vec{v} \times \vec{r}_p|}$. But $|\vec{v} \times \vec{r}_p| = v r_p \sin(\theta)$ where θ is the angle formed between \vec{v} and \vec{r}_p and $v \sin(\theta) = v_{\perp}$. It follows that the unit vector in the direction of the magnetic field may be given as $\hat{e}_B = \frac{\vec{v} \times \vec{r}_p}{r_p v_{\perp}}$ and the magnetic field vector at the point can be given as $\vec{B} = \frac{\mu_0 q v_{\perp}}{4\pi r_p^2} \hat{e}_B = \frac{\mu_0 q v_{\perp}}{4\pi r_p^2} \left(\frac{\vec{v} \times \vec{r}_p}{r_p v_{\perp}} \right)$. Therefore

$$\vec{B} = \frac{\mu_0 q}{4\pi r_p^3} \vec{v} \times \vec{r}_p$$

If \vec{r} and \vec{r}' are the position vectors of the point and the charge with respect to any coordinate system respectively, then $\vec{r}_p = \vec{r} - \vec{r}'$ and $r_p = |\vec{r} - \vec{r}'|$; and the magnetic field at point P may also be written as

$$\vec{B} = \frac{\mu_0 q}{4\pi |\vec{r} - \vec{r}'|^3} \vec{v} \times (\vec{r} - \vec{r}')$$

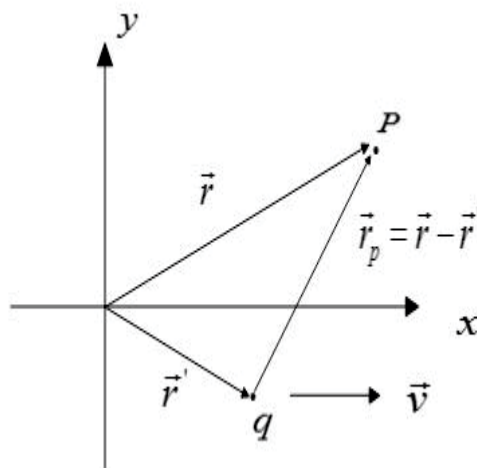

Figure 11.1

Example: Consider a proton travelling to the right along the x-axis with a speed 4000 m/s.

a) By the time the proton crosses the origin, calculate the magnetic field a point on the y-axis at $y = 0.003$ m.

Solution:

$$q = 1.6 \times 10^{-19} \text{ C}; \vec{v} = 4000 \text{ m/s } \hat{i}; \vec{r}' = 0 \text{ (because the charge is located at the origin)}; \vec{r} = (0, 0.003) \text{ m} = 0.003 \text{ m } \hat{j}$$

$$\vec{B} = ?$$

$$\vec{r} - \vec{r}' = (0.003 \hat{j} - 0) \text{ m} = 0.003 \text{ m } \hat{j}; |\vec{r} - \vec{r}'| = 0.003 \text{ m}$$

$$\vec{v} \times (\vec{r} - \vec{r}') = (4000 \hat{i}) \times (0.003 \hat{j}) \text{ m}^2 / \text{s} = 12 \hat{k} \text{ m}^2 / \text{s}$$

$$\vec{B} = \frac{\mu_0 q}{4\pi |\vec{r} - \vec{r}'|^3} \vec{v} \times (\vec{r} - \vec{r}') = \frac{4\pi \times 10^{-7} \times 1.6 \times 10^{-19}}{4\pi (0.003)^3} (12 \hat{k}) \text{ T} = \underline{7 \times 10^{-18} \hat{k} \text{ T}}$$

b) By the time the proton crosses the origin, calculate the magnetic field at a point located on the x-axis at $x = 0.006$ m.

Solution:

$$\vec{r}' = 0 \text{ (because the charge is located at the origin)}; \vec{r} = (0.006, 0) \text{ m} = 0.006 \hat{i} \text{ m}; \vec{B} = ?$$

$$\vec{r} - \vec{r}' = (0.006 \hat{i} - 0) \text{ m} = 0.006 \hat{i} \text{ m}$$

$$\vec{v} \times (\vec{r} - \vec{r}') = (4000 \hat{i} \text{ m/s}) \times (0.006 \hat{i} \text{ m}) = 0$$

$$\therefore \vec{B} = 0$$

c) By the time the proton is located on the x-axis at $x = 0.004$ m, Calculate the magnetic field at the point $(0.005, -0.009)$ m.

Solution:

$$\vec{r}' = (0.004, 0) \text{ m} = 0.004\hat{i} \text{ m}; \vec{r} = (0.005, -0.009) \text{ m} = (0.005\hat{i} - 0.009\hat{j}) \text{ m}; \vec{B} = ?$$

$$\vec{r} - \vec{r}' = (0.005\hat{i} - 0.009\hat{j}) \text{ m} - (0.004\hat{i}) \text{ m} = (0.001\hat{i} - 0.009\hat{j}) \text{ m}$$

$$|\vec{r} - \vec{r}'| = \sqrt{0.001^2 + (-0.009)^2} \text{ m} = 9.06 \text{ m}$$

$$\vec{v} \times (\vec{r} - \vec{r}') = (4000\hat{i} \text{ m/s}) \times (0.001\hat{i} - 0.009\hat{j}) \text{ m} = -36\hat{k} \text{ m}^2/\text{s}$$

$$\therefore \vec{B} = \frac{\mu_0 q}{4\pi |\vec{r} - \vec{r}'|^3} \vec{v} \times (\vec{r} - \vec{r}') = \frac{4\pi \times 10^{-7} \times 1.6 \times 10^{-19}}{4\pi (9.06 \times 10^{-3})^3} (-36\hat{k}) \text{ T} = \underline{-0.775 \times 10^{-19} \hat{k} \text{ T}}$$

Magnetic Field due to a Current carrying Wire

The magnetic field at a certain point P due to a current carrying wire is the vector sum of the magnetic fields due to all of the moving charges in the wire. Therefore the field may be calculated by first obtaining an expression for the field due to a small representative charge and then integrating over all the moving charges.

qaiteye
Challenge the way we run

EXPERIENCE THE POWER OF FULL ENGAGEMENT...

.....

**RUN FASTER.
RUN LONGER..
RUN EASIER...**

READ MORE & PRE-ORDER TODAY
WWW.GAITEYE.COM

Let $d\vec{s}$ be a small path element of the wire whose position vector with respect to a certain coordinate system is \vec{r}' . Let dq be the charge that crosses the path element $d\vec{s}$ in a time interval dt . That means the velocity of the charge dq by the time it crosses the path element is $\vec{v} = \frac{d\vec{s}}{dt}$. Then, if \vec{r} is the position vector of the point where the magnetic field is to be calculated and $d\vec{B}$ is the magnetic field at this point due to the charge dq $d\vec{B} = \frac{\mu_0 dq}{4\pi|\vec{r}-\vec{r}'|^3} \vec{v} \times (\vec{r}-\vec{r}')$. And since $\vec{v} = \frac{d\vec{s}}{dt}$, it follows that $d\vec{B} = \frac{\mu_0 dq}{4\pi|\vec{r}-\vec{r}'|^3} \frac{d\vec{s}}{dt} \times (\vec{r}-\vec{r}') = \frac{\mu_0}{4\pi|\vec{r}-\vec{r}'|^3} \frac{dq}{dt} d\vec{s} \times (\vec{r}-\vec{r}')$. But $\frac{dq}{dt} = I$ which is the rate of flow of charge or current in the wire. Therefore the magnetic field due to the charge dq may be written as $d\vec{B} = \frac{\mu_0 I}{4\pi|\vec{r}-\vec{r}'|^3} d\vec{s} \times (\vec{r}-\vec{r}')$. The net magnetic field at the point is obtained by adding the contributions from all the path elements. In other words, it is obtained by integrating this expression over the total length of the wire.

$$\vec{B} = \frac{\mu_0 I}{4\pi} \int \frac{d\vec{s} \times (\vec{r} - \vec{r}')}{|\vec{r} - \vec{r}'|^3}$$

This relationship is known as Biot-Savart law.

Magnetic Field due to a current carrying straight wire at a point located on the same line as the wire

If the point is located on the same line as the wire, then $d\vec{s}$ and $\vec{r}_p = \vec{r} - \vec{r}'$ are parallel and $d\vec{s} \times \vec{r}_p = 0$. Therefore, it follows that the magnetic field at any point located on the same line as the wire is zero.

$$\vec{B} = 0$$

Magnetic field at the center of a circle of radius R due to any current carrying arc of the circle that subtends a central angle $\Delta\phi$

Consider a current carrying arc that is a part of a circle of radius R that lies on the xy -plane centered at the origin. Let $d\vec{s}$ be an arbitrary path element on the arc whose position vector is \vec{r}' . Then $\vec{r} = 0$ because the point is located at the origin, $\vec{r}' = R \cos(\phi) \hat{i} + R \sin(\phi) \hat{j}$ where ϕ is angle formed between \vec{r}' and the positive x -axis and $d\vec{s} = ds \hat{e}_\phi = ds (-\sin(\phi) \hat{i} + \cos(\phi) \hat{j})$.

$$\vec{r}_p = \vec{r} - \vec{r}' = 0 - (R \cos(\phi) \hat{i} + R \sin(\phi) \hat{j}) = -R \cos(\phi) \hat{i} - R \sin(\phi) \hat{j}$$

$$|\vec{r} - \vec{r}'| = \sqrt{(-R \cos[\phi])^2 + (-R \sin[\phi])^2} = R$$

$$d\vec{s} \times (\vec{r} - \vec{r}') = ds(-\sin(\phi)\hat{i} + \cos(\phi)\hat{j}) \times (-R\cos(\phi)\hat{i} - R\sin(\phi)\hat{j}) = Rds\sin^2(\phi)\hat{k} + Rds\cos^2(\phi)\hat{k} = Rds\hat{k}$$

And with $ds = R d\phi$, $d\vec{s} \times (\vec{r} - \vec{r}') = R^2 d\phi \hat{k}$. Therefore $\vec{B} = \frac{\mu_0}{4\pi} I \int \frac{d\vec{s} \times (\vec{r} - \vec{r}')}{|\vec{r} - \vec{r}'|^3} = \frac{\mu_0 R^2 I}{4\pi}$

$$\hat{k} \int_{\phi}^{\phi+\Delta\phi} \frac{d\phi}{R^3} = \frac{\mu_0 I}{4\pi R} \hat{k} \int_{\phi}^{\phi+\Delta\phi} d\phi \text{ and the field is given as}$$

$$\vec{B} = \frac{\mu_0 I \Delta\phi}{4\pi R} \hat{k}$$

Even though in this particular case where the arc is on the xy -plane the direction is \hat{k} , generally, the direction is the same as the direction of the area of the loop (\hat{e}_A). Remember, the direction of area is always perpendicular to the plane of the loop and is related to the counter clock wise direction by the right hand rule. Therefore, generally, the magnetic field at the center of the arc can be written in terms of a unit vector in the direction of the area of the plane of the loop as

$$\vec{B} = \frac{\mu_0 I \Delta\phi}{4\pi R} \hat{e}_A$$

In this formula, the current I should be taken to be positive if the direction of the current is counter clock wise and negative if it is clock wise.

Alternatively, first the magnitude of the field can be determined from

$$B = \frac{\mu_0 |I| \Delta\phi}{4\pi R}$$

And then the direction can be determined from the right hand rule. When fingers are wrapped in the direction of the current, the direction of thumb represents the direction of the field.

Magnetic Field at the center of a current carrying circular loop

The magnetic field at the center of a current carrying circular loop can be obtained from the expression for the field of an arc that subtends an angle $\Delta\phi$. For a complete circular loop $\Delta\phi = 2\pi$ and

$$\vec{B} = \frac{\mu_0 I}{2R} \hat{e}_A$$

Alternatively, first the magnitude of the field can be determined from

$$B = \frac{\mu_0 |I|}{2R}$$

And then the direction can be determined from the right hand rule. When fingers are wrapped in the direction of the current, the direction of thumb represents the direction of the field. If the loop has N turns, then the magnetic field will be N times stronger and

$$\vec{B} = \frac{\mu_0 NI}{2R} \hat{e}_A$$

Example: Calculate the magnetic field due to a wire in the shape of an arc that is one sixth of a circle of radius 0.2 m at the center of the circle when it carries a current of 4 A in a clock wise direction. Assume the arc lies on the xy -plane.

Solution:

$$R = 0.2 \text{ m}; \Delta\phi = \frac{1}{6}(2\pi) = \frac{\pi}{3}; \hat{e}_A = \hat{k} \quad (\text{since the wire lies on the } xy\text{-plane})$$

$I = -4 \text{ A}$ (negative because the direction of the current is clockwise); $\vec{B} = ?$

$$\vec{B} = \frac{\mu_0 I \Delta\phi}{4\pi R} \hat{e}_A = \frac{4\pi \times 10^{-7} \times (-4) \times \left(\frac{\pi}{3}\right)}{4\pi \times 0.2} \hat{k} = \underline{-2.1 \times 10^{-6} \text{ T } \hat{k}}$$

This e-book
is made with
SetaPDF

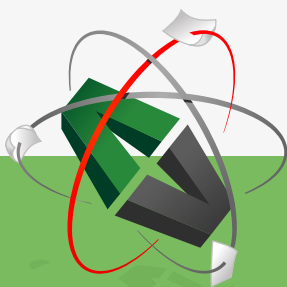

PDF components for PHP developers

www.setasign.com

Alternatively, the direction can be obtained from the right hand rule. When fingers are wrapped in a clockwise direction, the thumb will point in the $-\hat{k}$ direction.

Example: Calculate the magnetic field at the center of a coil of radius 0.1 m and 100 turns when it carries current of 2 A in a counter clockwise direction. Assume the coil lies in the yz -plane.

Solution:

$$R = 0.1 \text{ m}; N = 100; \hat{e}_A = \hat{i} \text{ (because the loop lies in the } yz\text{-plane)}$$

$$I = 2 \text{ A (positive because it is flowing in a counter clockwise direction); } \vec{B} = ?$$

$$\vec{B} = \frac{\mu_0 NI}{2R} \hat{e}_A = \frac{4\pi \times 10^{-7} \times 100 \times 2}{2 \times 0.1} \hat{i} = \underline{4\pi \times 10^{-4} \text{ T } \hat{i}}$$

Alternatively, the direction can be determined from the right hand rule. When fingers are wrapped in a counter clockwise direction on the yz -plane, thumb will point in the direction of the positive x -axis.

Example: Consider two concentric current carrying loops that lie on the xy -plane. The inner wire has a radius of 0.3 m and carries a current of 5 A in a clockwise direction. The outer wire has a radius of 0.4 m and carries a current of 2 A in a counter clockwise direction. Calculate the net magnetic field at the center of the loops due to both wires.

Solution: Let the inner and outer wires be represented by subscripts 1 and 2 respectively.

$$R_1 = 0.3 \text{ m}; \hat{e}_{1,A} = \hat{k}; I_1 = -5 \text{ A}$$

$$R_2 = 0.4 \text{ m}; \hat{e}_{2,A} = \hat{k}; I_2 = 2 \text{ A}$$

$$\vec{B}_{net} = \vec{B}_1 + \vec{B}_2 = ?$$

$$\vec{B}_{net} = \vec{B}_1 + \vec{B}_2 = \frac{\mu_0 I_1}{2R_1} \hat{e}_{1,A} + \frac{\mu_0 I_2}{2R_2} \hat{e}_{2,A} = \frac{\mu_0 \hat{k}}{2} \left(\frac{I_1}{R_1} + \frac{I_2}{R_2} \right) = \frac{4\pi \times 10^{-7} \hat{k}}{2} \left(\frac{-5}{0.3} + \frac{2}{0.4} \right) = \underline{-7.33 \times 10^{-6} \text{ T } \hat{k}}$$

Example: Consider the wire shown that carries a current of 0.6 A. Calculate the magnetic field at the center of the arc.

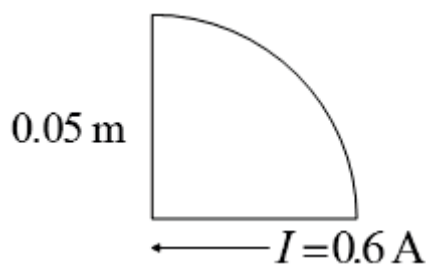

Figure 11.2

Solution: The magnetic field at the center of the arc due to the straight wires is zero because the point lies in the same lines as the wires. There is contribution only from the arc.

$$R = 0.05 \text{ m}; I = -0.6 \text{ A}; \hat{e}_A = -\hat{k}; \Delta\phi = \frac{\pi}{2}; \vec{B} = ?$$

$$\vec{B} = \frac{\mu_0 I \Delta\phi}{4\pi R} \hat{e}_A = \frac{4\pi \times 10^{-7} \times (-0.6) \times \frac{\pi}{2}}{4\pi \times 0.05} (\hat{k}) = \underline{-1.9 \times 10^{-6} \text{ T } \hat{k}}$$

Example: Consider the wire shown that carries a current of 2 A in the direction shown. The inner and outer arcs have radii 0.03 m and 0.05 m respectively. Calculate the magnetic field at the center of the arcs.

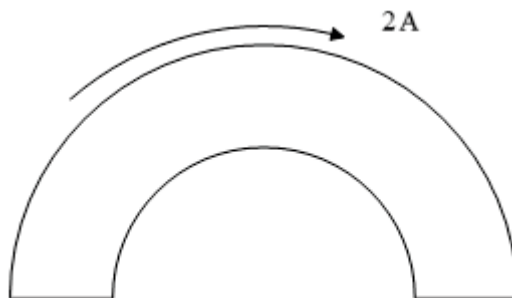

Figure 11.3

Solution: Let the inner and the outer arcs be represented by subscripts 1 and 2 respectively. The magnetic fields due to the two straight wires is zero because the center of the arcs lies in the same line as these wires do. The only contribution comes from the inner and outer arcs.

$R_1 = 0.03 \text{ m}$; $\hat{e}_{1,A} = \hat{k}$; $\Delta\phi_1 = \pi$; $I_1 = 2 \text{ A}$ (positive because the current is flowing counter clockwise in the inner wire)

$R_2 = 0.05 \text{ m}$; $\hat{e}_{2,A} = \hat{k}$; $\Delta\phi_2 = \pi$; $I_2 = -2 \text{ A}$ (negative because the current is flowing clockwise in the outer arc)

$\vec{B}_{net} = \vec{B}_1 + \vec{B}_2 = ?$

$$\vec{B} = \frac{\mu_0 I_1 \Delta\phi_1}{4\pi R_1} \hat{e}_{1,A} + \frac{\mu_0 I_2 \Delta\phi_2}{4\pi R_2} \hat{e}_{2,A} = \frac{\mu_0 \hat{k}}{4\pi} \left(\frac{I_1 \Delta\phi_1}{R_1} + \frac{I_2 \Delta\phi_2}{R_2} \right) = \frac{4\pi \times 10^{-7} \hat{k}}{4\pi} \left(\frac{2\pi}{0.03} + \frac{-2\pi}{0.05} \right) = \underline{8.4 \times 10^{-6} \text{ T } \hat{k}}$$

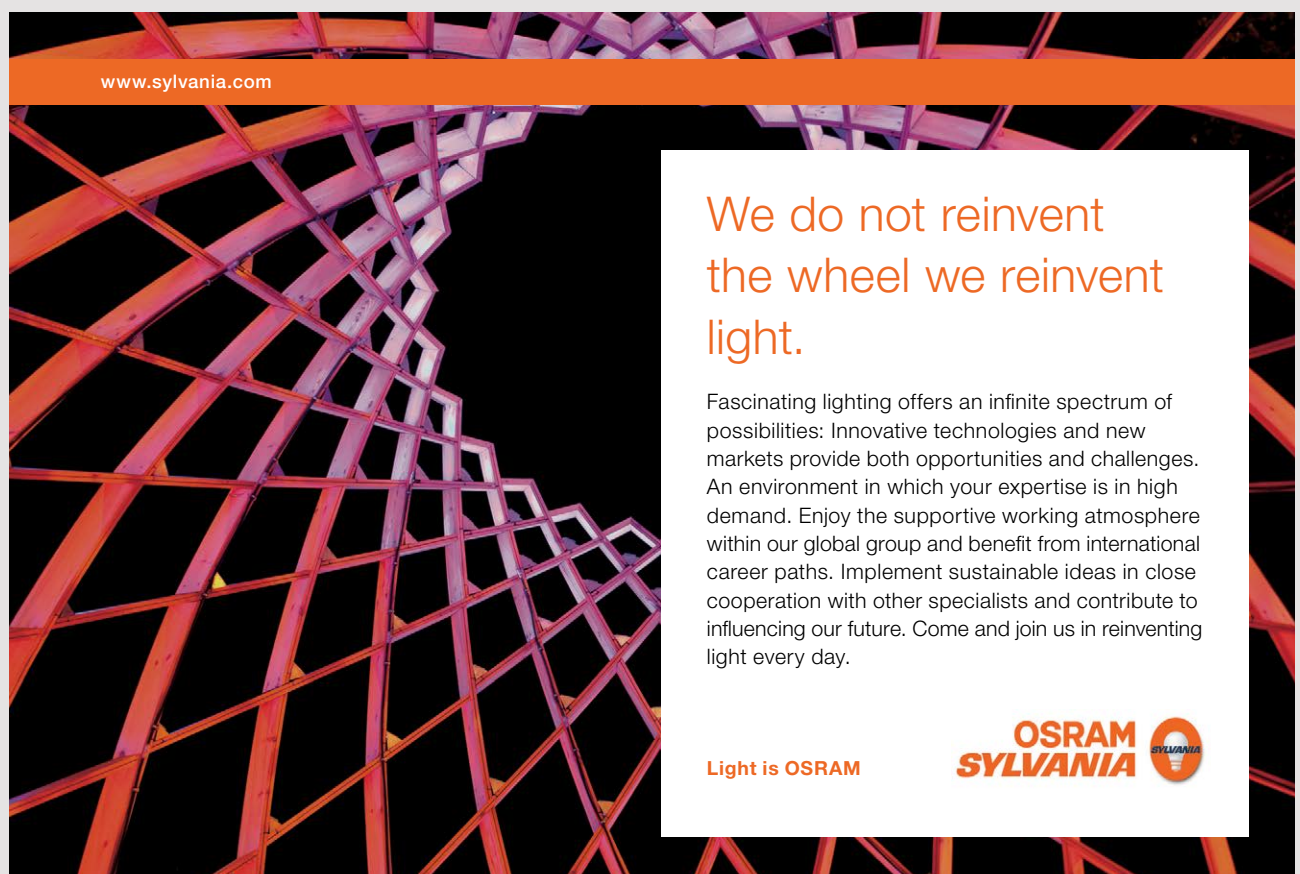

www.sylvania.com

We do not reinvent the wheel we reinvent light.

Fascinating lighting offers an infinite spectrum of possibilities: Innovative technologies and new markets provide both opportunities and challenges. An environment in which your expertise is in high demand. Enjoy the supportive working atmosphere within our global group and benefit from international career paths. Implement sustainable ideas in close cooperation with other specialists and contribute to influencing our future. Come and join us in reinventing light every day.

Light is OSRAM

OSRAM SYLVANIA

Magnetic field on the axis of a current carrying circular loop

Consider a circular loop of radius R carrying current I on xy -plane centered at the origin. Let the point at which the magnetic field is to be obtained be located on the axis of the loop which in this case is the z -axis. Let the coordinate of the point be $(0, 0, a)$. Then the position vector of the point is $\vec{r} = a\hat{k}$. Let $d\vec{s}$ be an arbitrary small path element on the circular loop. Let the angle formed between the position vector of $d\vec{s}$ and the positive x -axis be ϕ . Then the position vector of the path element $d\vec{s}$ is $\vec{r}' = R\cos\phi\hat{i} + R\sin\phi\hat{j}$. Therefore $\vec{r} - \vec{r}' = a\hat{k} - R\cos\phi\hat{i} - R\sin\phi\hat{j}$ and $|\vec{r} - \vec{r}'| = \sqrt{R^2 + a^2}$. The path element $d\vec{s}$ is tangent to the circle and thus its direction is along the tangential unit vector $\hat{e}_\phi = -\sin(\phi)\hat{i} + \cos(\phi)\hat{j}$ which implies that $d\vec{s} = ds[-\sin(\phi)\hat{i} + \cos(\phi)\hat{j}]$. But $ds = R d\phi$ and this may also be written as $d\vec{s} = -\sin\phi R d\phi \hat{i} + \cos\phi R d\phi \hat{j}$. Now $d\vec{s} \times (\vec{r} - \vec{r}') = \cos\phi R a d\phi \hat{i} + \sin\phi R a d\phi \hat{j} + R^2 d\phi \hat{k}$ and using Biot-Savart law the magnetic field at the point whose position vector \vec{r} is given as $\vec{B} = \frac{\mu_0 I}{4\pi} \int \frac{d\vec{s} \times (\vec{r} - \vec{r}')}{|\vec{r} - \vec{r}'|^3} = \frac{\mu_0 I}{4\pi (a^2 + R^2)^{3/2}} \int_0^{2\pi} (\cos\phi R a d\phi \hat{i} + \sin\phi R a d\phi \hat{j} + R^2 d\phi \hat{k})$. The \hat{i} and \hat{j} components of this integral vanish because the integrals of cosine and sine over a full revolution are zero. Therefore the magnetic field on the axis of a current carrying circular wire is given as $\vec{B} = \frac{\mu_0 I R^2}{2(a^2 + R^2)^{3/2}} \hat{k}$. Even though in this particular case where the loop is on the xy -plane, the direction is \hat{k} , generally, the direction is the direction of the area of the plane of the loop (\hat{e}_A). So generally, it may be expressed as

$$\vec{B} = \frac{\mu_0 I R^2}{2(a^2 + R^2)^{3/2}} \hat{e}_A$$

In this formula, the current should be taken to be positive if the direction of the current is counter clock wise and negative if the direction is clockwise. Alternatively, first the magnitude can be calculated from $B = \frac{\mu_0 |I| R^2}{2(a^2 + R^2)^{3/2}}$ and then the direction can be determined from the right hand rule. When fingers are wrapped in the direction of the current, thumb represents the direction of the field. At the center of the circular loop, since $a = 0$, the magnetic field is given as $\vec{B} = \frac{\mu_0 I}{2R} \hat{e}_A$.

Magnetic Field on the perpendicular Bisector of current carrying finite straight wire

Consider a wire that extends between $z = -b$ and $z = b$ along the z -axis and carries a current I . Let point where the magnetic field is to be obtained be on the perpendicular bisector of the wire and let the perpendicular distance between the wire and the point be r_{\perp} . The perpendicular bisector is the $z = 0$ plane or the xy -plane. Therefore any point on the perpendicular bisector has the coordinate $(x, y, 0)$. Let $d\vec{s}$ be a small path element on the wire as shown. Then $d\vec{s} = dz\hat{k}$, $\vec{r}' = z\hat{k}$, $\vec{r} = x\hat{i} + y\hat{j} = r_{\perp}(\cos(\phi)\hat{i} + \sin(\phi)\hat{j})$, $\vec{r} - \vec{r}' = r_{\perp}(\cos(\phi)\hat{i} + \sin(\phi)\hat{j}) - z\hat{k}$, $|\vec{r} - \vec{r}'| = \sqrt{z^2 + r_{\perp}^2}$ and $d\vec{s} \times \vec{r} = r_{\perp} dz(-\sin(\phi)\hat{i} + \cos(\phi)\hat{j}) = r_{\perp} dz\hat{e}_{\phi}$ where \hat{e}_{ϕ} is a tangential unit vector tangent to a circle of radius r_{\perp} centered at the origin passing through the point in a counter clockwise direction. Now, from Biot-savart law, the magnetic field at the point is given by $\vec{B} = \frac{\mu_0 I}{4\pi} \int \frac{d\vec{s} \times (\vec{r} - \vec{r}')}{|\vec{r} - \vec{r}'|^3} = \frac{\mu_0}{4\pi} I r_{\perp} \hat{e}_{\phi} \int_{-b}^b \frac{dz}{(z^2 + r_{\perp}^2)^{3/2}}$ which integrates to the following expression for the magnetic field on the perpendicular bisector of a finite wire.

$$\vec{B} = \frac{bI\mu_0}{2\pi r_{\perp} \sqrt{b^2 + r_{\perp}^2}} \hat{e}_{\phi}$$

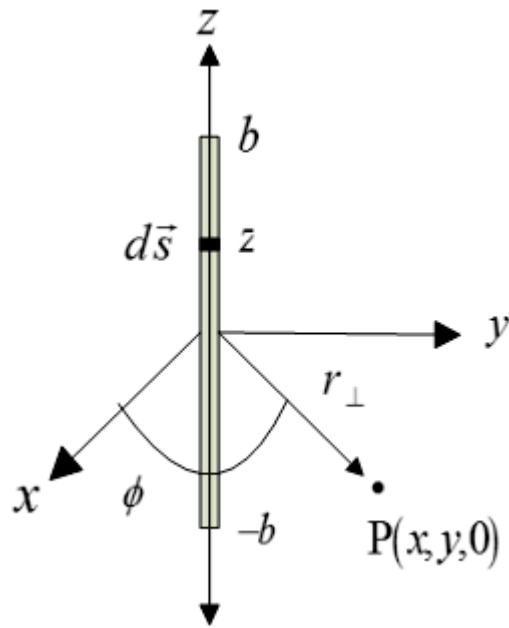

Figure 11.4



Discover the truth at www.deloitte.ca/careers

Deloitte.

© Deloitte & Touche LLP and affiliated entities.

Download free eBooks at bookboon.com

 Click on the ad to read more

In using this formula, the current should be taken to be positive when it is flowing in the positive z direction and negative when it is flowing in the negative z direction. \hat{e}_ϕ is a unit vector tangent to a circle concentric with the wire passing through the point. That is, $\hat{e}_\phi = \cos(\phi)\hat{i} + \sin(\phi)\hat{j}$ where ϕ is the angle formed between \vec{r}_\perp and the x -axis. Alternatively, first the magnitude can be calculated from $B = \frac{b|I|\mu_0}{2\pi r_\perp \sqrt{b^2 + r_\perp^2}}$ and then the direction can be determined from the right hand rule. When thumb points in the direction of the current then direction of fingers represents the direction of the field at the given point.

Magnetic field due to a current carrying infinitely long straight wire

For an infinitely long wire, any point can be taken to be on the perpendicular bisector of the wire. Therefore the field at any point can be obtained from the expression for the field on the perpendicular bisector of a finite wire by taking the limit as b approaches infinity. Therefore if the perpendicular distance between a point and an infinite current carrying straight wire is r_\perp , then the magnetic field at the point is given by $\vec{B} = \lim_{b \rightarrow \infty} \left\{ \frac{I\mu_0 b}{2\pi r_\perp \sqrt{b^2 + r_\perp^2}} \hat{e}_\phi \right\}$; which simplifies to the following expression.

$$\vec{B} = \frac{I\mu_0}{2\pi r_\perp} \hat{e}_\phi$$

In this formula, the current should be taken to be positive if the current is flowing in the direction of positive z -axis and negative if it is flowing in the direction of negative z -axis.

Alternatively, the magnitude and the direction can be determined separately. The magnitude of the field (B) at a point a perpendicular distance (r_\perp) is given by $B = \frac{|I|\mu_0}{2\pi r_\perp}$. The direction can be obtained by considering the magnetic field lines. Since the direction of the field is always tangent to a circle concentric with the wire, it follows that magnetic field lines due to a current carrying infinitely long straight wire must be circles concentric with the wire. The line tangent to the circular field line at the given point gives the line of action of the magnetic field at the given point. To distinguish between the two possible directions of the tangent line (related to clockwise or counterclockwise along the circle), the right hand rule is used. If thumb is aligned along the direction of the current and fingers are wrapped around the wire, the direction of the fingers represents the direction of the arrow along the circular field lines.

Example: A long straight wire is carrying a current of 2 A to the right.

a) Determine the magnitude and direction of the magnetic field due to the current in the wire at a point 2 m above the wire (on the plane of the paper).

Solution: The direction of the field is tangent to a concentric circle passing through the point. The plane of the concentric circle is perpendicular to the plane of the paper. That means, the direction of the field is either perpendicularly in or perpendicularly out. To distinguish between these two directions, the right hand rule can be used. When the thumb is aligned to the right, the fingers are wrapped in a direction that comes out of the paper. The direction of the field must be perpendicularly out (\cdot).

$$I = 2 \text{ A}; r_{\perp} = 2 \text{ m}; B = ?$$

$$B = \frac{\mu_0 |I|}{2\pi r_{\perp}} = \frac{4\pi \times 10^{-7} \times 2}{2\pi \times 2} \text{ T} = 2 \times 10^{-7} \text{ T}$$

$$\vec{B} = 2 \times 10^{-7} \text{ T perpendicularly out } (\cdot) \text{ or } \vec{B} = 2 \times 10^{-7} \hat{k} \text{ T}$$

b) Determine the magnitude and direction of the field due to the current in the wire at a point 4 m below the wire (on the plane of the paper).

Solution: The direction of the field is tangent to a concentric circle passing through the point. The plane of the concentric circle is perpendicular to the plane of the paper. That means, the direction of the field is either perpendicularly in or perpendicularly out. To distinguish between these two directions, the right hand rule can be used. When the thumb is aligned to the right, the fingers are wrapped in a direction that goes into the paper. The direction of the field must be perpendicularly in (\times).

$$I = 2 \text{ A}; r_{\perp} = 4 \text{ m}; B = ?$$

$$B = \frac{\mu_0 |I|}{2\pi r_{\perp}} = \frac{4\pi \times 10^{-7} \times 2}{2\pi \times 4} \text{ T} = 2 \times 10^{-7} \text{ T}$$

$$\vec{B} = 2 \times 10^{-7} \text{ T perpendicularly out } (\cdot) \text{ or } \vec{B} = 2 \times 10^{-7} \hat{k} \text{ T}$$

Example: A long straight wire is carrying a current of 5 A perpendicularly into the plane of the paper. Determine the magnitude and direction of the field at a point 2.5 m to the right of the wire.

Solution: The direction of the field is tangent to a concentric circle passing through the point. The plane of the concentric circle is the same as the plane of the paper. Therefore the direction of the field is either north (towards the top of the paper) or south (towards the bottom of the paper). The right hand rule can be used to distinguish between these two directions. If the thumb is directed perpendicularly in, then the fingers are wrapped in a clockwise direction. Therefore the direction of the field must be south.

$$|I| = 5 \text{ A}; r_{\perp} = 2.5 \text{ m}; B = ?$$

$$B = \frac{\mu_0 |I|}{2\pi r_{\perp}} = \frac{4\pi \times 10^{-7} \times 5}{2\pi \times 2.5} \text{ T} = 4 \times 10^{-7} \text{ T}$$

$$\vec{B} = 4 \times 10^{-7} \text{ T south or } \vec{B} = -4 \times 10^{-7} \hat{j} \text{ T}$$

Example: Wire 1 and 2 penetrate the xy -plane perpendicularly on the x -axis at the origin and at $x = 2 \text{ m}$ respectively. Wire 1 carries a current of 4 A . Wire 2 carries a current of 2 A . If the directions of both currents are perpendicularly out of the xy -plane, calculate the net magnetic field at a point on the x -axis midway between the wires.

SIMPLY CLEVER

ŠKODA



We will turn your CV into
an opportunity of a lifetime



Do you like cars? Would you like to be a part of a successful brand?
We will appreciate and reward both your enthusiasm and talent.
Send us your CV. You will be surprised where it can take you.

Send us your CV on
www.employerforlife.com



Download free eBooks at bookboon.com

Click on the ad to read more

Solution: From the right hand rule the direction of the magnetic field due to wire 1 at the point is north ($\vec{B}_1 = B_1 \hat{j}$); and that due to wire 2 is south ($\vec{B}_2 = -B_2 \hat{j}$).

$$I_1 = 4 \text{ A}; I_2 = 2 \text{ A}; r_{\perp 1} = 1 \text{ m}; r_{\perp 2} = 1 \text{ m}; \vec{B}_{net} = ?$$

$$B_1 = \frac{I_1 \mu_0}{2\pi r_{\perp 1}} = \frac{(4)(4\pi \times 10^{-7})}{2\pi(1)} \text{ T} = 8 \times 10^{-7} \text{ T}$$

$$B_2 = \frac{I_2 \mu_0}{2\pi r_{\perp 2}} = \frac{(2)(4\pi \times 10^{-7})}{2\pi(1)} \text{ T} = 4 \times 10^{-7} \text{ T}$$

$$\vec{B}_{net} = \vec{B}_1 + \vec{B}_2 = B_1 (\hat{j}) - B_2 \hat{j} = (B_1 - B_2) \hat{j} = (8 \times 10^{-7} - 4 \times 10^{-7}) \hat{j} \text{ T} = 4 \times 10^{-7} \hat{j} \text{ T}$$

Magnetic Force between two infinitely long parallel current carrying wires

Consider wires 1 and 2 which are parallel to the z-axis separated by a perpendicular distance of d_{12} .

Let wire 2 lie along the z-axis. Let \vec{B}_{12} be the magnetic field at the location of wire 1 due to wire 2

which is given by $\vec{B}_{12} = \frac{\mu_0 I_2}{2\pi d_{12}} \hat{e}_\phi$. Let $\vec{l} = l\hat{k}$ be a part of wire 1. Then the magnetic force exerted by the field due to wire 2 on this part of wire 1 is given as $\vec{F}_{12} = I_1 \vec{l} \times \vec{B}_{12} = I_1 (l\hat{k}) \times \left(\frac{\mu_0 I_2}{2\pi d_{12}} \hat{e}_\phi \right) = \frac{\mu_0 I_1 I_2 l}{2\pi d_{12}} (\hat{k} \times \hat{e}_\phi)$

But $\hat{k} \times \hat{e}_\phi = \hat{k} \times (-\sin(\phi)\hat{i} + \cos(\phi)\hat{j}) = -(\cos(\phi)\hat{i} + \sin(\phi)\hat{j}) = -\hat{e}_{12}$ where \hat{e}_{12} is a unit vector perpendicular to the wires directed from the wire exerting force (wire 2) to the wire being

acted upon (wire 1). In other words $\hat{e}_{12} = \frac{\vec{d}_{12}}{d_{12}}$ where \vec{d}_{12} is a vector perpendicular to the wires whose tail is on the wire exerting force (wire 2) and whose head is on the wire being

acted upon (wire 1). Now the force can be written as $\vec{F}_{12} = \frac{-\mu_0 I_1 I_2 \ell}{2\pi d_{12}} \hat{e}_{12}$. But since the wires are infinite, it makes more sense to deal with the force per unit length exerted by wire 2

on wire 1 which is given by

$$\frac{\vec{F}_{12}}{l} = \frac{-\mu_0 I_1 I_2}{2\pi d_{12}} \hat{e}_{12}$$

When the wires carry currents in the same direction, the product $I_1 I_2$ is positive and the force exerted by wire 2 on wire 1 is attraction. And when they carry currents in opposite directions, the product $I_1 I_2$ is negative and the force exerted by wire 2 on wire 1 is repulsion. The forces exerted by wire 2 on wire 1 and by wire 1 on wire 2 are action reaction forces ($\vec{F}_{21} = -\vec{F}_{12}$). It follows that the two wires attract each other when they carry currents in the same direction and repel each other when they carry currents in the opposite directions. Alternatively, first the magnitude of the force per unit length can be calculated from $\frac{F_{12}}{\ell} = \frac{\mu_0 |I_1| |I_2|}{2\pi d_{12}}$ and then, the direction of the force can be determined from the fact that they attract each other when they carry currents in the same direction and repel each other when they carry currents in opposite direction.

Example: Two long parallel and horizontal wires are separated by a distance of 0.5 m on the plane of the paper. The upper wire carries a current of 5 A to the right and the lower wire carries a current of 8 A to the left. Determine the magnitude and direction of the force per unit length exerted by the lower wire on the upper wire.

Solution: Since the wires are carrying wires in opposite directions, they repel each other. Therefore the direction of the force exerted by the lower wire on the upper wire must be north.

$$I_1 = 5 \text{ A}; I_2 = -8 \text{ A}; d_{12} = 0.5 \text{ m}; F_{12} / \ell = ?$$

$$\frac{F_{12}}{\ell} = \frac{\mu_0 |I_1| |I_2|}{2\pi d_{12}} = \frac{4\pi \times 10^{-7} \times 5 \times 8}{2\pi \times 0.5} \text{ N/m} = 1.6 \times 10^{-5} \text{ N/m}$$

$$\frac{\vec{F}_{12}}{\ell} = 1.6 \times 10^{-5} \text{ N/m north or } \frac{\vec{F}_{12}}{\ell} = 1.6 \times 10^{-5} \hat{j} \text{ N/m}$$

Practice Quiz 8.1

Choose the best answer

1. Consider a proton travelling to the right along the x-axis with a speed of $4e6 \text{ m/s}$. By the time the charge crosses the point located at $x = 0.00048 \text{ m}$, calculate the magnetic field at a point located on the y-axis at $y = 9.6e-3 \text{ m}$.
A. $8.994e-16 \text{ T } \mathbf{k}$
B. 0
C. $5.535e-16 \text{ T } \mathbf{k}$
D. $6.918e-16 \text{ T } \mathbf{k}$
E. $7.61e-16 \text{ T } \mathbf{k}$

2. Consider a proton travelling to the left along the x -axis with a speed of $7e6$ m/s. By the time the charge crosses the point located at $x = 0.00072$ m, determine the direction of the magnetic field at a point located on the z -axis at $z = 5.7e-3$ m.
- A. \mathbf{j}
 - B. $-\mathbf{j}$
 - C. \mathbf{k}
 - D. $-\mathbf{k}$
 - E. \mathbf{i}
3. Calculate the magnetic field at the center of a circular coil of radius 0.061 m and number of turns 200 that lies on the xy -plane if it carries a current of 4.6 A in a clockwise direction.
- A. $-113715.354e-7$ T \mathbf{k}
 - B. $-94762.795e-7$ T \mathbf{k}
 - C. $85286.515e-7$ T \mathbf{k}
 - D. $94762.795e-7$ T \mathbf{k}
 - E. $113715.354e-7$ T \mathbf{k}

I joined MITAS because
I wanted **real responsibility**

The Graduate Programme
for Engineers and Geoscientists
www.discovermitas.com



Month 16

I was a construction
supervisor in
the North Sea
advising and
helping foremen
solve problems

Real work
International opportunities
Three work placements



 **MAERSK**

4. Consider two concentric circular wires on the xy -plane. The radii of the outer and inner wires are 0.33 m and 0.081 m respectively. The outer wire carries a current of 2.2 A in a clockwise direction and the inner wire carries a current of 3.3 A in a counter clockwise direction. Calculate the net magnetic field at the center of the wires.
- A. $214.094e-7$ T \mathbf{k}
B. 0
C. $-297.87e-7$ T \mathbf{k}
D. $297.87e-7$ T \mathbf{k}
E. $-214.094e-7$ T \mathbf{k}
5. Consider a straight wire that extends from -0.83 m to 0.83 m and carries a current of 5 A. Calculate the strength of the magnetic field on the z -axis at $z = 0.72$ m.
- A. $6.295e-7$ T
B. $12.59e-7$ T
C. $13.639e-7$ T
D. $10.492e-7$ T
E. $9.442e-7$ T
6. A long straight wire carrying a current of 5.5 A towards west lies along the x -axis of an xy -coordinate plane. Determine the magnitude of the magnetic field at a point located on the y -axis at $y = -0.21$ m.
- A. $73.333e-7$ T
B. $47.143e-7$ T
C. $36.667e-7$ T
D. $41.905e-7$ T
E. $52.381e-7$ T
7. A long straight wire penetrates the origin of an xy -coordinate plane perpendicularly. If the wire carries a current perpendicularly into the plane, determine the direction of the magnetic field at a point on the y -axis at $y = -2$ m.
- A. perpendicularly in
B. south
C. east
D. north
E. west

8. Consider two infinitely long parallel wires A and B. Wire A lies along the x-axis and carries a current of 7 A to the left. Wire B lies on the line $y = 2$ m and carries a current of 8 A to the left. Calculate the magnetic field at a point located at $y = 0.4$ m on the y-axis.
- A. $-45e-7 \mathbf{k}$ T
B. $45e-7 \mathbf{k}$ T
C. $-25e-7 \mathbf{k}$ T
D. $25e-7 \mathbf{k}$ T
E. 0
9. Wire A lies horizontally on the x-axis of an xy-coordinate plane and carries a current of 5.6 A to the right. Wire B is parallel to wire A, lies 3.8 m above wire A on the xy-coordinate plane and carries a current of 2.1 A to the right. Determine the magnitude of the force per unit length exerted by wire A on wire B.
- A. $6.189e-7$ N/m
B. $5.571e-7$ N/m
C. $3.714e-7$ N/m
D. $4.333e-7$ N/m
E. $7.427e-7$ N/m
10. Wire A lies horizontally on the x-axis of an xy-coordinate plane and carries a current to the right. Wire B is parallel to wire A, lies 6.2 m above wire A on the xy-coordinate plane and carries a current to the right. Determine the direction of the force per unit length exerted by wire A on wire B.
- A. north
B. perpendicularly in
C. perpendicularly out
D. south
E. west
11. Consider three infinitely long parallel wires A, B, and C. Wire A lies along the x-axis and carries a current of 16 A to the right. Wire B lies along the line $y = 2.1$ m and carries a current of 20 A to the left. Wire C lies along the line $y = 5.2$ m and carries a current of 15 A to the left. Calculate the net force per unit length exerted on wire B by wires A and C.
- A. $-77.849e-7 \mathbf{j}$ N/m
B. $-111.214e-7 \mathbf{j}$ N/m
C. $-498.31e-7 \mathbf{j}$ N/m
D. $498.31e-7 \mathbf{j}$ N/m
E. $111.214e-7 \mathbf{j}$ N/m

Ampere's Law

Line integral of Magnetic Field on a Path

Line integral of magnetic field on a certain path is the integral of the dot product between an arbitrary small path element ($d\vec{s}$) on the path and the magnetic field (\vec{B}) at the location of the path element integrated over the entire path. Let the line integral be represented by L . Then

$$L = \int_{\text{path}} \vec{B} \cdot d\vec{s}$$

If θ is the angle formed between \vec{B} and $d\vec{s}$, then $\vec{B} \cdot d\vec{s} = B ds \cos(\theta)$ and the line integral may also be written as

$$L = \int_{\text{path}} B \cos(\theta) ds$$

Example: The magnetic field in a certain region varies according to the equation $\vec{B} = \frac{1}{y} \hat{i} + \frac{1}{x} \hat{j}$. Calculate the line integral of the magnetic field on the straight line joining the point (1,2) m to the point (2, 4) m.

ie business school

#1 EUROPEAN BUSINESS SCHOOL
FINANCIAL TIMES 2013

#gobeyond

MASTER IN MANAGEMENT

Because achieving your dreams is your greatest challenge. IE Business School's Master in Management taught in English, Spanish or bilingually, trains young high performance professionals at the beginning of their career through an innovative and stimulating program that will help them reach their full potential.

- Choose your area of specialization.
- Customize your master through the different options offered.
- Global Immersion Weeks in locations such as London, Silicon Valley or Shanghai.

Because you change, we change with you.

www.ie.edu/master-management | mim.admissions@ie.edu | f t in YouTube

Solution:

$$(x_1, y_1) = (1, 2); (x_2, y_2) = (2, 4) \text{ m}; \vec{B} = \frac{1}{y} \hat{i} + \frac{1}{x} \hat{j}; L = ?$$

First let's find the equation of the path which is a straight line. If (x, y) is an arbitrary point on the line, then $\text{slope} = \frac{y-2}{x-1} = \frac{4-2}{2-1} = 2$. Therefore the equation of the line is $y = 2x$.

$$L = \int_{(0,0)}^{(4,2)} \vec{B} \cdot d\vec{s} = \int_{(0,0)}^{(4,2)} \left(\frac{1}{y} \hat{i} + \frac{1}{x} \hat{j} \right) \cdot (dx \hat{i} + dy \hat{j}) = \int_{(0,0)}^{(4,2)} \left(\frac{dx}{y} + \frac{dy}{x} \right) \text{ subjected to the relationship } y = 2x.$$

$y = 2x \Rightarrow dy = 2dx$. Therefore substituting for y and dy in terms of x

$$L = \int_{x=1}^{x=2} \left(\frac{dx}{2x} + \frac{2dx}{x} \right) = \frac{5}{2} \int_{x=1}^{x=2} \frac{dx}{x} = \frac{5}{2} (\ln(2) - \ln(1)) = \frac{5 \ln(2)}{2} = \underline{1.73 \text{ Tm}}$$

Line integral of a constant magnetic field

If \vec{B} is a constant, then it can be taken out of the integral and $L = \vec{B} \cdot \int_{\text{path}} d\vec{s}$. But $\int_{\text{path}} d\vec{s} = \Delta\vec{r} = \vec{r}_f - \vec{r}_i$ where \vec{r}_f and \vec{r}_i are the position vectors of the ending point and starting point of the path respectively. $\Delta\vec{r}$ is the vector whose tail is at the initial point of the path and whose head is at the final point of the path independent of the shape of the path. Therefore the line integral of a constant magnetic field may be written as

$$L = \vec{B} \cdot \Delta\vec{r} = B \cos(\theta) |\Delta\vec{r}|$$

Example: The magnetic field in a certain region is given by $\vec{B} = (0.002\hat{i} - 0.005\hat{j})$ T. Calculate the line integral of the magnetic field on an arc of a circle centered at the origin that extends from the point $(0.2, 0)$ m to the point $(0, 0.2)$ m.

Solution:

$$\vec{B} = (0.002\hat{i} - 0.005\hat{j}) \text{ T}, \vec{r}_i = (0.2, 0) \text{ m} = 0.2\hat{i}; \vec{r}_f = (0, 0.2) \text{ m} = 0.2\hat{j}; L = ?$$

$$L = \vec{B} \cdot \Delta\vec{r} = \vec{B} \cdot (\vec{r}_f - \vec{r}_i) = (0.002\hat{i} - 0.005\hat{j}) \cdot (0.2\hat{j} - 0.2\hat{i}) \text{ Tm} = \underline{-0.0014 \text{ Tm}}$$

Ampere's Law

Ampere's law states that the line integral of the magnetic field on any closed path is proportional to the total current crossing the closed path.

$$\oint \vec{B} \cdot d\vec{s} = \mu_0 I$$

Where I represents the total current crossing the closed path. This integral should be done in a counter clockwise direction. The current is taken to be positive if its direction is related to a counter clock wise direction in applying the right hand rule and negative if its direction is related to a clock wise direction in a applying the right hand rule. For example if the closed path lies on the xy -plane, a current flowing in the direction of the positive z -axis will be taken to be positive because when thumb points along the positive z -axis, fingers will be wrapped in a counter clock direction; and a current flowing in the direction of the negative z -axis is taken to be negative because when thumb points along the negative z -axis, fingers have to be wrapped in a clock wise direction. This means the usual positive direction (right, up) are taken to be positive and the usual negative directions (left, down) are taken to be negative.

Example: The magnetic field in a certain region is $4\hat{i} \mu\text{T}$ when $y \geq 0$ and $-2\hat{i} \mu\text{T}$ when $y < 0$. Calculate the total current that crosses the rectangular path whose corners are located at the points A(-0.05,-0.03) m, B(0.05,-0.03) m, C(0.05,0.03) m and (-0.05,0.03) m.

Solution:

$$\oint \vec{B} \cdot d\vec{s} = \mu_0 I$$

(Remember the integral has to be done in a counter clockwise direction)

$$\oint \vec{B} \cdot d\vec{s} = \int_{AB} \vec{B} \cdot d\vec{s} + \int_{BC} \vec{B} \cdot d\vec{s} + \int_{CD} \vec{B} \cdot d\vec{s} + \int_{DA} \vec{B} \cdot d\vec{s}$$

The line integrals on paths BC and DA are zero because the field and the path are perpendicular to each other.

$$\therefore \oint \vec{B} \cdot d\vec{s} = \int_{AB} \vec{B} \cdot d\vec{s} + \int_{CD} \vec{B} \cdot d\vec{s}$$

$$\int_{AB} \vec{B} \cdot d\vec{s} = \vec{B}_{y < 0} \cdot \Delta\vec{r}_{AB} \text{ but } \Delta\vec{r}_{AB} = 0.1\hat{i} \text{ m and } \vec{B}_{y < 0} = -2 \times 10^{-6} \hat{i} \text{ T}$$

$$\therefore \int_{AB} \vec{B} \cdot d\vec{s} = -2 \times 10^{-7} \text{ Tm}$$

$$\int_{CD} \vec{B} \cdot d\vec{s} = \vec{B}_{y \geq 0} \cdot \Delta\vec{r}_{CD} \text{ But } \Delta\vec{r}_{CD} = -0.1\hat{i} \text{ m and } \vec{B}_{y \geq 0} = 4 \times 10^{-7} \hat{i} \text{ T}$$

$$\therefore \int_{CD} \vec{B} \cdot d\vec{s} = -4 \times 10^{-7} \text{ Tm}$$

$$\oint \vec{B} \cdot d\vec{s} = \mu_0 I = (-2 - 4) \times 10^{-7} \text{ Tm} = -6 \times 10^{-7} \text{ Tm}$$

$$\therefore I = \frac{-6 \times 10^{-7}}{4\pi \times 10^{-7}} \text{ A} = -0.477 \text{ A}$$

The negative sign means the direction of the current is perpendicularly into the xy -plane (or in the $-\hat{k}$ direction)

Example: The magnetic field on the xy -plane varies on the distance from the origin r according to the equation $\vec{B} = \frac{3 \times 10^{-6}}{r} \hat{e}_\phi$ where \hat{e}_ϕ is a tangential unit vector. Calculate the total current crossing a circular path of radius 0.004 m centered at the origin.

Solution:

$$r = 0.004 \text{ m}; I = ?$$

For a circular path centered at the origin $d\vec{s} = ds\hat{e}_\phi$. Therefore $\vec{B} \cdot d\vec{s} = \frac{3 \times 10^{-6}}{r} \hat{e}_\phi \cdot ds\hat{e}_\phi = \frac{3 \times 10^{-6} ds}{r}$

$$\therefore \oint \vec{B} \cdot d\vec{s} = \mu_0 I = \oint \frac{3 \times 10^{-6} ds}{r} = \frac{3 \times 10^{-6}}{r} \oint ds = \frac{3 \times 10^{-6}}{r} 2\pi r = 6\pi \times 10^{-6} \text{ Tm}$$

$$I = \frac{6\pi \times 10^{-6}}{4\pi \times 10^{-7}} \text{ A} = 15 \text{ A} \text{ (Positive current means the direction of the current is perpendicularly out of the } xy\text{-plane or in the } \hat{k} \text{ direction)}$$



"I studied English for 16 years but...
...I finally learned to speak it in just six lessons"

Jane, Chinese architect

ENGLISH OUT THERE

Click to hear me talking before and after my unique course download

Applications of Ampere's law

1. Magnetic field due to an infinitely long current carrying straight wire

The following conclusions can be inferred from symmetry: a) The magnetic field lines must be circular lines concentric with the wire. b) The magnitude of the magnetic field on a circle concentric with the wire must be constant.

Consider a wire penetrating the plane of the paper perpendicularly. Even though the choice of the closed path is arbitrary, it should be chosen in such a way as it simplifies the problem, In this case it is easier to choose the closed path to be one of the concentric circular field lines. Let the radius of this circle be r_{\perp} . Since the field is tangent to the field lines, on this path \vec{B} and $d\vec{s}$ the same line of action. $d\vec{s} = ds\hat{e}_{\phi}$ where \hat{e}_{ϕ} is a counterclockwise tangential unit vector and $\vec{B} = B_s\hat{e}_{\phi}$ where B_s is the component of the magnetic field in the direction of \hat{e}_{ϕ} . B_s is positive (negative) if the direction of the magnetic field lines is counterclockwise (clockwise). Now $\vec{B} \cdot d\vec{s} = B_s ds$ and applying Ampere's Law, $\oint B_s ds = 2\pi r_{\perp} B_s = \mu_0 I$ where I is the current in the wire. Therefore $B_s = \frac{\mu_0 I}{2\pi r_{\perp}}$ and the vector magnetic field is given as

$$\vec{B} = \frac{\mu_0 I}{2\pi r_{\perp}} \hat{e}_{\phi}$$

Which is the same with the expression obtained in previous section using Biot-Savart Law.

2. Magnetic field inside a solenoid

A solenoid is a coil. The following conclusions can be made about a solenoid from symmetry: a) The magnetic field just outside a solenoid is approximately zero. b) The field inside a solenoid is approximately constant & parallel to the axis of the solenoid.

Let the number of turns of the solenoid be N and let its length be l . Let the current be I . To take advantage of the symmetries, the closed path is chosen to be a rectangle with one of the side inside (parallel to its axis) and the other outside (both sides being parallel to the axis of the solenoid). This closed path is being crossed by the wires N times. Therefore the net current crossing the closed path is N time I and from Ampere's law, $\oint \vec{B} \cdot d\vec{s} = \mu_0 NI$. The integral is zero on the side that lies outside the solenoid because the field is approximately zero over there. The integral is also zero on the sides that are perpendicular to the axis of the solenoid because outside $B = 0$ & inside \vec{B} and $d\vec{s}$ are perpendicular to each other ($B ds \cos 90^\circ = 0$). Therefore the non-zero contribution comes only from the side inside the solenoid that is parallel to the axis of the solenoid. On this path, $\vec{B} = B_s \hat{e}_A$ and $d\vec{s} = ds \hat{e}_A$ where \hat{e}_A is a unit vector in the direction of the cross-sectional area of the solenoid and B_s is the component of the field in the direction of \hat{e}_A . Now $\vec{B} \cdot d\vec{s} = B_s ds$ and applying Ampere's law $\oint \vec{B} \cdot d\vec{s} = \oint B_s ds = B_s l = \mu_0 NI$. Therefore, $B_s = \frac{\mu_0 NI}{l}$ and the vector magnetic field is given as

$$\vec{B} = \frac{\mu_0 NI}{l} \hat{e}_A$$

In using this formula, the current is taken to be positive (negative) if it is flowing in a counterclockwise (clockwise) direction. The direction of the magnetic field and the direction of the current are related by the right hand rule; That is, when fingers are wrapped around the solenoid in the direction of the current, thumb will point in the direction of the field. Therefore, alternatively, the magnitude of the magnetic field can be obtained from $B = \frac{\mu_0 N |I|}{l}$ and then the direction of the field can be determined from the right hand rule. Customarily the ratio $\frac{N}{l}$ (which is number of turns per a unit length) is denoted by n and this formula may also be written as $B = \mu_0 n I$.

Example: A solenoid of length 0.05 m has 200 turns. It carries a current of 9 A. The direction of the current is clockwise as seen from the side of its right end.

a) Calculate the field inside the solenoid.

Solution:

$l = 0.05$ m; $N = 200$; $I = 9$ A; $B = ?$

$$B = \frac{\mu_0 NI}{l} = \frac{4\pi \times 10^{-7} \times 200 \times 9}{0.05} \text{ T} = 4.5 \times 10^{-3} \text{ T}$$

b) Determine whether its North Pole is its right end or its left end.

Solution: When the fingers are wrapped around the solenoid in a clockwise direction as seen from the right end, the thumb points towards the left. Therefore the direction of the field must be towards the left. And since magnetic field lines come out of the North Pole, the North Pole is the left end.

Excellent Economics and Business programmes at:



university of
 groningen



“The perfect start
of a successful,
international career.”

CLICK HERE
to discover why both socially
and academically the University
of Groningen is one of the best
places for a student to be

www.rug.nl/feb/education

3. Magnetic field inside a toroid

A toroid is a circular magnetic material with electric wire wound around it. From symmetry, the following conclusions can be inferred: a) The field inside the toroid is approximately constant b) The field lines inside the toroid are circles concentric with the center on the toroid. Let its radius be R , number of turns be N and current be I . Let's choose the closed path for applying Ampere's law be a circle (concentric with its center) inside the toroid. Since the field lines are also circular \vec{B} (which is tangent to the circle) and $d\vec{s}$ have the same line of action. On this path, $\vec{B} = B_s \hat{e}_\phi$ and $d\vec{s} = ds \hat{e}_\phi$ where \hat{e}_ϕ is a counterclockwise tangential unit vector (which is in the direction of the cross-sectional area of the toroid at any point) and B_s is the component of the field in the direction of \hat{e}_ϕ ; and $\vec{B} \cdot d\vec{s} = B_s ds$. This closed path is being crossed N times by the coils and thus the net crossing current is NI . Applying Ampere's law, $\oint \vec{B} \cdot d\vec{s} = \oint B_s ds = B_s (2\pi R) = \mu_0 NI$. Therefore $B_s = \frac{\mu_0 NI}{2\pi R}$ and the vector field is given as

$$\vec{B} = \frac{\mu_0 NI}{2\pi R} \hat{e}_\phi$$

In using this formula, the current is taken to be positive (negative) if the current is flowing in a counterclockwise (clockwise) direction around the toroid. The direction of the field inside a toroid (that is whether clockwise or counterclockwise) is related with the direction of the current by the right hand rule. If fingers are wrapped around the toroid in the direction of the current then thumb will point in the direction of the field. Therefore, alternatively, the magnitude of the field can be determined from $B = \frac{\mu_0 N |I|}{2\pi R}$ and then the direction of the field can be determined from the right hand rule.

4. Field due to an infinitely long thick cylindrical wire

Consider a cylindrical wire of radius R carrying current I . The fields inside and outside will be treated separately.

a) *Magnetic field outside wire* ($r_{\perp} > R$): From symmetry, the field lines are circular lines concentric with the cylinder and the magnitude is constant on this circle. Taking the closed path to be one of these circles, the current crossing the loop is I ; and the path element $d\vec{s}$ and field \vec{B} have the same line of action. On this path, $\vec{B} = B_s \hat{e}_{\phi}$ and $d\vec{s} = ds \hat{e}_{\phi}$ where \hat{e}_{ϕ} is a counterclockwise tangential unit vector (which is in the direction of the cross-sectional area of the toroid at any point) and B_s is the component of the field in the direction of \hat{e}_{ϕ} ; and $\vec{B} \cdot d\vec{s} = B_s ds$. Therefore $\oint \vec{B} \cdot d\vec{s} = \oint B_s ds = B_s 2\pi r_{\perp} = \mu_0 I$. Therefore, $B_s = \frac{\mu_0 I}{2\pi r_{\perp}}$ and the vector field outside the cylindrical wire is given as

$$\vec{B} = \frac{\mu_0 I}{2\pi r_{\perp}} \hat{e}_{\phi}$$

b) *Magnetic field inside wire* ($r_{\perp} < R$): Even though the same symmetry conditions apply, now with the circular closed path of radius $r_{\perp} < R$, only part of the current crosses this closed path. If the current density is J , then $J = \frac{I}{\pi R^2}$ (remember $I = JA$). If I_{\perp} is the current crossing the circular path of radius $r_{\perp} < R$, then $I_{\perp} = J\pi r_{\perp}^2 = \left(\frac{I}{\pi R^2}\right)\pi r_{\perp}^2 = I\left(\frac{r_{\perp}}{R}\right)^2$. Now $\oint \vec{B} \cdot d\vec{s} = 2\pi r_{\perp} B_s = \mu_0 I_{\perp} = \mu_0 \frac{r_{\perp}^2}{R^2} I$ and the field inside the wire is given as

$$\vec{B} = \frac{\mu_0 I r_{\perp}}{2\pi R^2} \hat{e}_{\phi}$$

Putting both cases together,

$$\vec{B} = \begin{cases} \frac{\mu_0 I}{2\pi r_{\perp}} \hat{e}_{\phi} & \text{if } r_{\perp} \geq R \\ \frac{\mu_0 I r_{\perp}}{2\pi R^2} \hat{e}_{\phi} & \text{if } r_{\perp} < R \end{cases}$$

Modification of Ampere's Law

Ampere's law which states that the integral of $\vec{B} \cdot d\vec{s}$ along a closed path is equal to μ_0 times the current crossing the closed path, was deduced by Ampere experimentally. But when Maxwell was developing the theory of electromagnetism, he found it necessary to include another kind of current in Ampere's law to make it consistent with the theory, this new kind of current is called *displacement current* (I_0). With this new type of current, the modified Ampere's law is written as $\oint \vec{B} \cdot d\vec{s} = \mu_0 (I + I_0)$. Maxwell found that the displacement current is proportional to the rate of change of electric flux with time; that is $I_0 = \epsilon_0 \frac{d\phi_E}{dt}$ where $\phi_E = \int \vec{E} \cdot d\vec{A}$ stands for the electric flux.

Therefore the modified Ampere's law can be written as

$$\oint \vec{B} \cdot d\vec{s} = \mu_0 \left(I + \epsilon_0 \frac{d\phi_E}{dt} \right)$$

American online LIGS University

is currently enrolling in the
Interactive Online **BBA, MBA, MSc,**
DBA and PhD programs:

- ▶ enroll **by September 30th, 2014** and
- ▶ **save up to 16%** on the tuition!
- ▶ pay in 10 installments / 2 years
- ▶ Interactive Online education
- ▶ visit www.ligsuniversity.com to find out more!

Note: LIGS University is not accredited by any nationally recognized accrediting agency listed by the US Secretary of Education. More info [here](#).



A very good example of a displacement current is the kind of current that exists between the plates of a parallel plate capacitor. Consider a charged capacitor connected to an external resistor. Current will flow in the circuit until the capacitor is fully discharged. Even though the plates of a capacitor are separated by an insulator, current flows continuously in the circuit. This is because there is a different kind of current between the plates of the capacitor that is called displacement current. The charge in the plates decreases, giving rise to a non-zero rate of change of electric flux $\frac{d\phi_E}{dt} = \frac{d}{dt}(EA) = A \frac{dE}{dt}$. Actually it can be shown that the displacement current between the plates is equal to the traditional current in the wire. Between the plates of a parallel plate the area and the field are parallel (They are both perpendicular to the plates. Using Gauss's law, it can be shown that the electric field inside is given in terms of the charge density (σ) as $E = \frac{\sigma}{\epsilon_0}$. If the total charge in the plate is Q , then $\sigma = \frac{Q}{A}$ where A is the area of the plates and the electric field may be written as $E = \frac{Q}{\epsilon_0 A}$. Therefore $\phi_E = \int \vec{E} \cdot d\vec{A} = EA = \frac{Q}{\epsilon_0}$ and hence the displacement current is given as $I_0 = \epsilon_0 \frac{d\phi_E}{dt} = \epsilon_0 \frac{d(Q/\epsilon_0)}{dt} = \frac{dQ}{dt}$ which is equal to the traditional current I .

Gauss' Law for Magnetic Field

Magnetic Flux

Magnetic Flux is a measure of the amount of magnetic field that crosses a certain area perpendicularly.

Consider a small area element $d\vec{A}$ (Remember area is a vector quantity whose direction is \perp to the plane of the area. When right hand fingers are wrapped around the area, a thumb gives the direction of the area). If the magnetic field at the location of $d\vec{A}$ is \vec{B} , then the magnetic flux is defined to be $B_{\perp} dA$ where B_{\perp} is the component of the magnetic field that crosses the area perpendicularly.

If the angle between $d\vec{A}$ & \vec{B} is θ , then $B_{\perp} = B \cos \theta$ and the flux ($d\phi_B$) is given by $d\phi_B = B \cos \theta dA = \vec{B} \cdot d\vec{A}$. The total flux (ϕ_B) crossing a certain area is obtained by integrating this on the whole area.

$$\phi_B = \int \vec{B} \cdot d\vec{A}$$

If B and θ are constant over the entire area, \vec{B} can be taken out of the integral and $\phi_B = \vec{B} \cdot \int d\vec{A}$. Or

$$\phi_B = \vec{B} \cdot \vec{A} = BA \cos(\theta)$$

The unit of measurement for magnetic flux is Tm^2 which is sometimes called the Weber.

Example: Consider a circular loop of radius 0.04 m on the plane of the paper.

a) Determine the magnitude and direction of the area of the loop.

Solution: The direction of the area can be obtained from the right hand rule. When fingers are wrapped around the loop in a counter clockwise direction, thumb points perpendicularly out. Thus the direction of the area is perpendicularly out from the plane of the paper (\cdot).

$$r = 0.04 \text{ m}; \vec{A} = ?$$

$$A = \pi r^2 = 3.14 \times 0.04^2 \text{ m}^2 = 0.005 \text{ m}^2$$

$$\vec{A} = 0.005 \hat{k} \text{ Tm}^2 = 0.005 \text{ Tm}^2 \text{ perpendicularly out } (\cdot)$$

b) Calculate the magnetic flux crossing the loop, when the loop is in a 5 T field directed to the right.

Solution: Since the field is parallel to the plane of the loop and the direction of area is perpendicularly out, the angle between area and field is 90° .

$$B = 5 \text{ T}; \theta = 90^\circ; \phi_B = ?$$

$$\phi_B = BA \cos(\theta) = 5 \times 0.005 \cos(90^\circ) = 0$$

c) Calculate the magnetic flux crossing the loop when it is in a 2 T field that penetrates the loop perpendicularly out.

Solution: Since both the area and the field are perpendicularly out, the angle between area and field is zero.

$$B = 2 \text{ T}; \theta = 0^\circ; \phi_B = ?$$

$$\phi_B = BA \cos(\theta) = 2 \times 0.005 \cos(0) \text{ Tm}^2 = 0.01 \text{ Tm}^2$$

d) Calculate the magnetic flux crossing the loop when a 0.4 T field penetrates the loop perpendicularly in.

Solution: Since the area is perpendicularly out and the field is perpendicularly in, the angle between the area and the field is 180°.

$$\phi_B = BA \cos(\theta) = 2 \times 0.005 \cos(0) \text{ Tm}^2 = 0.01 \text{ Tm}^2$$

$$\phi_B = BA \cos(\theta) = 0.5 \times 0.005 \cos(0) \text{ Tm}^2 = -0.0025 \text{ Tm}^2$$

Gauss' Law for Magnetic Field

Gauss' law for magnetic field states that the magnetic flux crossing any closed surface is zero.

$$\oint_{\text{closed surface}} \vec{B} \cdot d\vec{A} = 0$$

This is basically a statement of the fact that magnetic field lines do not originate or sink anywhere but form complete loops.

.....Alcatel-Lucent 

www.alcatel-lucent.com/careers

What if you could build your future and create the future?

One generation's transformation is the next's status quo. In the near future, people may soon think it's strange that devices ever had to be "plugged in." To obtain that status, there needs to be "The Shift".



Practice Quiz 8.2

Choose the best answer

- Which of the following is a correct statement?
 - The magnetic field due to a current carrying solenoid just outside the solenoid is approximately zero.
 - The magnetic field lines due to a current carrying solenoid inside the solenoid are circles concentric with the axis of the solenoid.
 - Two long straight wires repel each other if they are carrying currents in the same direction.
 - Ampere's law states the magnetic force between two current carrying wires is inversely proportional to the square of the perpendicular distance between the wires.
 - The magnetic field strength at a point inside a solenoid is inversely proportional to the perpendicular distance between the point and the axis of the solenoid.
- Which of the following statements is a correct statement?
 - The line integral of the magnetic field along any closed path is proportional to the total current crossing the closed loop.
 - The magnitude of the magnetic field at a certain point due to an infinitely small element of a current carrying wire is inversely proportional to the distance between the path element and the point.
 - Displacement current is proportional to the rate of change of magnetic flux.
 - The surface integral of the magnetic field on a closed surface is proportional to the total magnetic moment enclosed inside the closed surface.
 - The direction of the magnetic field at a certain point due to an infinitely small element of a current carrying wire is directed along the position vector of the point with respect to the path element.
- The magnetic field in a certain region is given by $\mathbf{B} = (15.6 \mathbf{i} + 14.6 \mathbf{j})$ T. Calculate the line integral of the magnetic field from the origin to the point $(0, 0.053)$ m along the straight line joining them.
 - 0.929 m T
 - 0.929 m T
 - 0.774 m T
 - 0.774 m T
 - 0

4. The magnetic field in a certain region is $-7.44e-6 \mathbf{j}$ T if x is less than zero and $8.54e-6 \mathbf{j}$ T if x is greater than or equal to zero. Calculate the total current crossing a rectangular region whose corners are located at $(-0.083, 0)$ m, $(0.083, 0)$ m, $(0.083, 0.67)$ m and $(-0.083, 0.67)$ m.
- A. 8.52 A perpendicularly in
 - B. 0
 - C. 8.52 A perpendicularly out
 - D. 6.816 A perpendicularly in
 - E. 6.816 A perpendicularly out
5. The magnetic field in a certain region varies according to the equation $\mathbf{B} = 1.81e-6 / r^{0.75} \mathbf{e}_\theta$. Calculate the total current that crosses a circular region of radius 0.75 m centered at the origin.
- A. 8.422 A perpendicularly out
 - B. 8.422 A perpendicularly in
 - C. 6.738 A perpendicularly out
 - D. 6.738 A perpendicularly in
 - E. 0
6. Wire A is carrying a current of 1 A perpendicularly into the x-y plane through the point (1, 0) m. Wire B is carrying a current of 7 A perpendicularly into the x-y plane through the point (2, 0) m. Wire C is carrying a current of 15 A perpendicularly out of the x-y plane through the point (3, 0) m. Calculate the line integral of the magnetic field due to the currents on a circular path of radius 1.5 m centered at the origin.
- A. $28.903e-6$ m T
 - B. 0
 - C. $8.796e-6$ m T
 - D. $-1.257e-6$ m T
 - E. $-10.053e-6$ m T
7. A solenoid is placed horizontally. It carries a current which is counter-clockwise as seen from the right end. Determine direction of the magnetic field inside the solenoid.
- A. north
 - B. east
 - C. perpendicularly into
 - D. west
 - E. south

8. A solenoid has a length of 0.07 m and has 200 turns. The field inside the solenoid is found to be $2.5e-3$ T. Determine the current of the solenoid.
- A. 0.627 A
 - B. 0.418 A
 - C. 0.696 A
 - D. 0.905 A
 - E. 0.836 A
9. A toroid with a radius of 0.1 m has 450 turns. Calculate the current flowing in the toroid if the magnetic field inside the toroid is found to be $7.4e-2$ T.
- A. 115.111 A
 - B. 106.889 A
 - C. 82.222 A
 - D. 74 A
 - E. 98.667 A



In the past four years we have drilled

81,000 km

That's more than **twice** around the world.

Who are we?
We are the world's leading oilfield services company. Working globally—often in remote and challenging locations—we invent, design, engineer, manufacture, apply, and maintain technology to help customers find and produce oil and gas safely.

Who are we looking for?
We offer countless opportunities in the following domains:

- **Engineering, Research, and Operations**
- **Geoscience and Petrotechnical**
- **Commercial and Business**

If you are a self-motivated graduate looking for a dynamic career, apply to join our team.

What will you be?

Schlumberger

careers.slb.com

10. There is a current density of $2.3e4 \text{ A m}^2$ in an infinitely long coaxial cable of radius $2.7e-2 \text{ m}$ whose axis lies along the x-axis. Calculate the magnitude of the magnetic field at a point located at $(6.6, 0.73) \text{ m}$.
- A. $11.545e-6 \text{ T}$
 - B. $14.432e-6 \text{ T}$
 - C. $15.875e-6 \text{ T}$
 - D. $10.102e-6 \text{ T}$
 - E. $20.204e-6 \text{ T}$
11. The plates of a parallel plate capacitor have an area of $7.1e-6 \text{ m}^2$ and are separated by a distance of 0.003 m . As the capacitor is charged, the current decreases according to the equation $I = 3.3e-9 e^{-1.4e6t}$. Calculate the rate of change of the electric field between the plates after $4.51e-9$ seconds.
- A. $0.418e8 \text{ N/C/s}$
 - B. $0.679e8 \text{ N/C/s}$
 - C. $0.522e8 \text{ N/C/s}$
 - D. $0.313e8 \text{ N/C/s}$
 - E. $0.47e8 \text{ N/C/s}$

9 FARADAY'S LAW

Faraday's Law states that whenever the magnetic flux crossing a loop changes with time, there will be an induced emf (\mathcal{E}) which is equal to the negative rate of change of magnetic flux

$$\mathcal{E} = -\frac{d\phi_B}{dt}$$

Where ϕ_B is the magnetic flux crossing the surface enclosed the loop. If the resistance of the loop is R , then induced current $I_{\text{ind}} = \frac{\mathcal{E}}{R}$ will flow in the circuit. If the induced emf is positive (negative), the current will flow in a counterclockwise (clockwise) direction. That means the current flows in a clockwise (counterclockwise) direction when the magnetic flux crossing the loop increases (decreases).

The average induced emf ($\bar{\mathcal{E}}$) over a time interval Δt can be obtained by integrating the induced emf over the time interval and dividing by the time interval: $\bar{\mathcal{E}} = \frac{1}{\Delta t} \int_t^{t+\Delta t} \mathcal{E} dt = -\frac{1}{\Delta t} \int_t^{t+\Delta t} \frac{d\phi_B}{dt} dt$ and the average induced emf is given by

$$\bar{\mathcal{E}} = -\frac{\Delta\phi_B}{\Delta t} = -\frac{(\phi_{Bf} - \phi_{Bi})}{\Delta t}$$

Where ϕ_{Bi} and ϕ_{Bf} stand for the initial and final magnetic flux crossing the loop respectively.

Example: A rectangular loop of sides 0.02 m and 0.04 m is placed in a region where there is a 6 mT field penetrating the loop perpendicularly in. The strength of the field is increased to 9 T in 0.2 seconds.

a) Calculate the average induced emf in the loop.

Solution: The direction of the area is perpendicularly out. Therefore the angle between the area and the field is 180° because the direction of the field is perpendicularly in. The area and the angle remain the same. Only the field strength changes.

$w = 0.02 \text{ m}; l = 0.04 \text{ m} (A_i = A_f = wl); B_i = 6 \text{ T}; B_f = 9 \text{ T}; \theta_i = \theta_f = 180^\circ; \Delta t = 0.2 \text{ s}; \bar{\mathcal{E}} = ?$

$$A_i = A_f = wl = 0.02 \times 0.04 \text{ m}^2 = 0.0008 \text{ m}^2$$

$$\phi_{Bi} = B_i A_i \cos(\theta_i) = 6 \times 0.0008 \cos(180^\circ) \text{ Tm}^2 = -0.0048 \text{ Tm}^2$$

$$\phi_{Bf} = B_f A_f \cos(\theta_f) = 9 \times 0.0008 \cos(180^\circ) \text{ Tm}^2 = -0.0072 \text{ Tm}^2$$

$$\bar{\varepsilon} = -\frac{\Delta\phi_B}{\Delta t} = -\frac{\phi_{Bf} - \phi_{Bi}}{\Delta t} = -\frac{-0.0072 - (-0.0048)}{0.2} \text{ V} = 0.012 \text{ V}$$

b) If the loop has a resistance of 10 ohm, calculate the induced current in the loop. Is the current flowing clockwise or counter clockwise?

Solution: Since the induced emf is positive, the current is flowing counter clockwise.

$R = 10 \Omega$; $I_{ind} = ?$

$$I_{ind} = \frac{\varepsilon}{R} = \frac{0.012}{10} = 0.0012 \text{ A}$$

Example: A square loop of side 2 m is placed in a region where there is a 5 T field whose direction is perpendicularly out of the plane of the loop. Its shape is changed to a circle in 0.5 s.



Maastricht University

Leading in Learning!

**Join the best at
the Maastricht University
School of Business and
Economics!**

Top master's programmes

- 33rd place Financial Times worldwide ranking: MSc International Business
- 1st place: MSc International Business
- 1st place: MSc Financial Economics
- 2nd place: MSc Management of Learning
- 2nd place: MSc Economics
- 2nd place: MSc Econometrics and Operations Research
- 2nd place: MSc Global Supply Chain Management and Change

Sources: Keuzegids Master ranking 2013; Elsevier 'Beste Studies' ranking 2012; Financial Times Global Masters in Management ranking 2012

Maastricht University is the best specialist university in the Netherlands (Elsevier)

**Visit us and find out why we are the best!
Master's Open Day: 22 February 2014**

www.mastersopenday.nl



a) Calculate the average induced emf in the loop.

Solution: The angle between the area and the field is zero because the direction for both of them is perpendicularly out. The field strength and the angle remain the same. Only the area is changing. As the shape changes, the perimeter (length of the wire) remains the same. If the side of the square is w and the radius of the circle is r , then $4w = 2\pi r$ and $r = \frac{2w}{\pi}$.

$$w = 2 \text{ m}; B_i = B_f = 5 \text{ T}; \theta_i = \theta_f = 0; \Delta t = 0.5; \bar{\varepsilon} = ?$$

$$A_i = w^2 = 2 \times 2 \text{ m}^2 = 4 \text{ m}^2$$

$$A_f = \pi r^2 = \pi \left(\frac{2w}{\pi} \right)^2 = \frac{4w^2}{\pi} = \frac{4 \times 2^2}{\pi} \text{ m}^2 = 5.1 \text{ m}^2$$

$$\phi_{Bi} = B_i A_i \cos(\theta_i) = 5 \times 4 \cos(0) \text{ Tm}^2 = 20 \text{ Tm}^2$$

$$\phi_{Bf} = B_f A_f \cos(\theta_f) = 5 \times 5.1 \cos(0) \text{ Tm}^2 = 25.5 \text{ Tm}^2$$

$$\bar{\varepsilon} = -\frac{\phi_{Bf} - \phi_{Bi}}{\Delta t} = -\frac{25.5 - 20}{0.5} \text{ V} = -11 \text{ V}$$

b) Is the induced current flowing clockwise or counter clockwise?

Solution: It is flowing clockwise because the induced emf is negative.

Example: A square loop of side 0.2 m is placed in a 4 T field that is parallel to the plane of the loop and directed to the right. The loop is rotated about its right side by 90° in 0.4 s so that the plane of the loop is perpendicular to the field. Calculate the average induced emf.

Solution: Initially the direction of the area is perpendicularly out. Thus, the initial angle is 90° because the field is parallel to the plane of the loop. As the loop is rotated, the direction of the area becomes parallel to the plane of the loop directed towards the right (as seen from the right). Therefore the final angle is zero because the field is also directed to the right. The magnitude of the area and the field strength remain the same.

$$w = 0.2 \text{ m} (A_i = A_f = w^2); B_i = B_f = 4 \text{ T}; \theta_i = 90^\circ; \theta_f = 0; \Delta t = 0.4 \text{ s}; \bar{\varepsilon} = ?$$

$$A_i = A_f = w^2 = 0.2^2 \text{ m}^2 = 0.04 \text{ m}^2$$

$$\phi_{Bi} = B_i A_i \cos(\theta_i) = 4 \times 0.04 \cos(90^\circ) \text{ Tm}^2 = 0$$

$$\phi_{Bf} = B_f A_f \cos(\theta_f) = 4 \times 0.04 \cos(0) \text{ Tm}^2 = 0.16 \text{ Tm}^2$$

$$\bar{\varepsilon} = -\frac{\phi_{Bf} - \phi_{Bi}}{\Delta t} = -\frac{0.16 - 0}{0.4} \text{ V} = -0.4 \text{ V}$$

Example: A loop of radius 0.05 m is placed around a solenoid of radius 0.04 m in such a way that it is concentric with the axis of the solenoid. The solenoid has 300 turns, is 0.06 m long and carries a current of 4 A in a clockwise direction as seen from the right (its axis is horizontal). The current is turned off in 0.004 seconds.

a) Calculate the average induced voltage in the loop enclosing the solenoid.

Solution: The magnetic field crossing the loop is that due to the solenoid. The field due to a solenoid is approximately zero outside the solenoid. Thus it is only the part of the loop that intersects the solenoid that is being crossed by a magnetic field. This means, in calculating the flux of the loop, the cross-sectional area of the solenoid and not the area of the loop should be used. The field inside a solenoid is given as $B = \frac{\mu_0 NI}{\ell}$. The direction of the area of the loop as seen from the right is to the right. From the right hand rule, the direction of the field inside the solenoid is to the left. Therefore the angle between the area and the field is 180° .

$N = 300$; $l = 0.06$ m; $I_i = 4$ A; $I_f = 0$; $r = 0.04$ m; $\theta_i = \theta_f = 180^\circ$; $\Delta t = 0.004$ s; $\bar{\varepsilon} = ?$

$$A_i = A_f = \pi r^2 = 3.14 \times 0.04^2 \text{ m}^2 = 0.005 \text{ m}^2$$

$$B_i = \mu_0 \frac{N}{\ell} I_i = 4 \times 3.14 \times 10^{-7} \frac{300}{0.06} \times 4 \text{ T} = 2.5 \times 10^{-2} \text{ T}$$

$$B_f = \mu_0 \frac{N}{\ell} I_f = 4 \times 3.14 \times 10^{-7} \times \frac{300}{0.06} * 0 \text{ T} = 0 \text{ T}$$

$$\phi_{Bi} = B_i A_i \cos(\theta_i) = 2.5 \times 10^{-2} \times 0.005 \cos(180^\circ) \text{ Tm}^2 = -1.25 \times 10^{-4} \text{ Tm}^2$$

$$\phi_{Bf} = B_f A_i \cos(\theta_f) = 0 \times 0.005 \cos(180^\circ) \text{ Tm}^2 = 0 \text{ Tm}^2$$

$$\bar{\varepsilon} = -\frac{\phi_{Bf} - \phi_{Bi}}{\Delta t} = -\frac{0 - (-1.25 \times 10^{-4})}{0.004} \text{ V} = -3.1 \times 10^{-2} \text{ V}$$

b) Is the induced current in the loop flowing clockwise or counter clockwise as seen from the right?

Solution: Since the induced voltage as seen from the right is negative, the direction of the induced current as seen from the right is clockwise.

Example: A square loop of side 0.2 m on the xy-plane is placed in a region where there is a magnetic field that varies with time according to the equation $\vec{B} = 3 \cos(100t)\hat{i} + 3 \sin(100t)\hat{j} + 10e^{-5t}\hat{k}$. Obtain an expression for the induced emf as a function of time.

Solution: Since the loop is in the xy-plane the direction of its area is \hat{k} .

$$w = 0.2 \text{ m } (A = w^2); \varepsilon(t) = ?$$

$$\vec{A} = 0.2^2 \hat{k} \text{ m}^2 = 0.04 \hat{k} \text{ m}^2$$

$$\phi_B = \vec{B} \cdot \vec{A} = (\vec{B} = 3 \cos(100t)\hat{i} + 3 \sin(100t)\hat{j} + 10e^{-5t}\hat{k}) \cdot (0.04\hat{k}) \text{ Tm}^2 = 0.4e^{-5t} \text{ Tm}^2$$

$$\varepsilon = -\frac{d\phi_B}{dt} = -\frac{d(0.4e^{-5t} \text{ Tm}^2)}{dt} = 2e^{-5t} \text{ V}$$



> Apply now

REDEFINE YOUR FUTURE
**AXA GLOBAL GRADUATE
PROGRAM 2015**

redefining / standards 

agence.cdg - © Photonostop

Motional emf

Motional emf (ε_m) is induced voltage produced by the motion of a rod in a U-shaped conductor placed in a magnetic field. The rod and the closed end of the U-shaped conductor form a loop. As the rod moves, the area of this loop changes resulting in the change of the magnetic flux crossing the loop which produces induced voltage. This induced voltage is called motional emf. Let's assume that the direction of the magnetic field is perpendicularly out of the plane of the U-shaped conductor. As the rod moves along the U-shaped conductor, its position (x) changes as a function of time. If the length of the rod is ℓ , then its area at a particular time is $A(t) = \ell x(t)$. Therefore, the magnetic flux crossing the loop at a certain time t is $\phi_B = A(t)B = \ell x(t)B$ and thus $\varepsilon_m = -\ell B \frac{dx(t)}{dt} = -\ell Bv$ where v is the speed of the rod. If only the numerical value is of interest, then

$$|\varepsilon_m| = B\ell v$$

Example: A rod of length ℓ and mass m is placed in a U-shaped conductor where there is a magnetic field whose strength is B and whose direction is perpendicularly into the plane of the U-shaped conductor. Then it is released initial speed v_0 from a U-shaped. If its resistance is R , find an expression for its speed and position (assume it started at $x = 0$) as a function of time.

Solution: As the rod moves, there will be an induced current in the rod. A current carrying rod in a magnetic field is acted upon by a magnetic force (F_B). From the right hand rule, it can be shown that this is a resistive force: $F_B = -I_{ind}\ell B$. Applying Newton's second law,

$F = ma = m \frac{dv}{dt} = -I_{ind} \ell B$. But $I_{ind} = \frac{\varepsilon_m}{R} = \frac{B\ell v}{R}$. Therefore $m \frac{dv}{dt} = -\frac{B^2 \ell^2}{R} v$ or $\frac{dv}{v} = -\frac{B^2 \ell^2}{mR} dt$. Integrating,

$\int_{v_0}^{v(t)} \frac{dv'}{v'} = -\frac{B^2 \ell^2}{mR} \int_0^t dt' = -\frac{B^2 \ell^2}{mR} t$ and the speed of the rod as a function of time is given as

$$v(t) = v_0 e^{-\frac{B^2 \ell^2}{mR} t}$$

And since, $v = \frac{dx}{dt}$ $\int_0^{x(t)} dx' = \int_0^t v_0 e^{-\frac{B^2 \ell^2}{mR} t'} dt'$ which gives the position of the rod as a function of time as

$$x(t) = \frac{v_0 mR}{B^2 \ell^2} \left(1 - e^{-\frac{B^2 \ell^2}{mR} t} \right)$$

Practice Quiz 9.1

Choose the best answer

- Which of the following is a correct statement?
 - Magnetic flux crossing a loop is defined to be the product of its area and the component of the magnetic field crossing the loop parallel to the plane of the loop.
 - Magnetic flux is a vector quantity.
 - Direction of area of a loop is perpendicular to the plane of the loop.
 - The unit of measurement for magnetic flux is Tesla / meter².
 - Faraday's law states that whenever the magnetic flux crossing a loop changes, an induced magnetic field is produced in the loop which is equal to the negative rate of change of flux with time.

- Which of the following is a correct statement?
 - Direction of the area of a loop can be obtained from the right hand rule as the direction of the thumb when fingers are wrapped around the loop in a counter-clockwise direction.
 - Direction of the area of a loop can be obtained from the right hand rule as the direction of the thumb when fingers are wrapped around the loop in a clockwise direction.
 - If the magnetic field crossing a loop is perpendicular to the plane of the loop, then the magnetic flux crossing the loop is zero.
 - If a loop on the xy-plane is penetrated by a magnetic field directed perpendicularly out of the plane, then the magnetic flux is negative.
 - All of the other statements are correct.

- A square loop of side 0.36 m is placed in a region where there is magnetic field of strength 19 T directed out of the plane of the loop making an angle of 20° with the plane of the loop. Calculate the magnetic flux crossing the loop.
 - 0.359 T m²
 - 0.161 T m²
 - 1.011 T m²
 - 0.842 T m²
 - 1.174 T m²

4. A circular loop of radius 0.67 m is placed in a region where there is a magnetic field of strength 17 T directed perpendicularly into the plane of the loop. The magnetic field is decreased to 2 T in 0.04 seconds. If the resistance of the loop is 10 Ohm, determine the average current induced in the loop.
- A. -76.77 A
B. -63.26 A
C. -47.385 A
D. -32.589 A
E. -52.885 A
5. A square loop of side 0.45 m and resistance 2 Ohm is placed in a region where there is a magnetic field of strength 14 T directed perpendicularly into the plane of the loop. If the shape of the square is changed to a circle in 0.8 seconds, Determine the average current induced in the loop.
- A. 0.588 A
B. 0.484 A
C. 0.324 A
D. 0.171 A
E. 0.686 A



The logo for BI Norwegian Business School features a central blue square with the letters 'BI' in white. Radiating from this center are numerous colorful, 3D-style rectangular bars in various colors (red, orange, yellow, green, blue, purple, pink). Each bar has a label for a business program: 'Business', 'Strategic Marketing Management', 'International Business', 'Leadership & Organisational Psychology', 'Shipping Management', and 'Financial Economics'.

Empowering People. Improving Business.

BI Norwegian Business School is one of Europe's largest business schools welcoming more than 20,000 students. Our programmes provide a stimulating and multi-cultural learning environment with an international outlook ultimately providing students with professional skills to meet the increasing needs of businesses.

BI offers four different two-year, full-time Master of Science (MSc) programmes that are taught entirely in English and have been designed to provide professional skills to meet the increasing need of businesses. The MSc programmes provide a stimulating and multi-cultural learning environment to give you the best platform to launch into your career.

- MSc in Business
- MSc in Financial Economics
- MSc in Strategic Marketing Management
- MSc in Leadership and Organisational Psychology

BI NORWEGIAN BUSINESS SCHOOL

EFMD
EQUIS
ACCREDITED

www.bi.edu/master

6. A square loop of side 0.56 m is placed in a region where there is a magnetic field of strength 2 T which is parallel to the plane of the loop. The loop is rotated by 90° in 0.8 seconds so that the plane of the loop is perpendicular to the field, If the resistance of the loop is 4 Ohm, calculate the average current induced in the loop.
- A. 0.297 A
 - B. 0 A
 - C. 0.196 A
 - D. 0.354 A
 - E. 0.238 A
7. A U shaped conductor is placed in a region where there is a 8.3 T magnetic field directed perpendicularly out of the plane of the U shaped conductor. If 18 V of emf is induced when a rod of length 1 m slides on the U shaped conductor, calculate the speed with which the rod is sliding.
- A. 3.244 m/s
 - B. 2.169 m/s
 - C. 1.307 m/s
 - D. 1.906 m/s
 - E. 2.812 m/s
8. The magnetic field in a certain region varies according to the equation $\mathbf{B} = 0.12 \cos(50t) \mathbf{i} + 0.12 \sin(50t) \mathbf{j} + 4.8 e^{-5.1t} \mathbf{k}$. Calculate the voltage induced after 1.2×10^{-3} seconds in a circular loop of radius 0.02 m on the xy-plane.
- A. -43.243×10^{-3} V
 - B. -24.843×10^{-3} V
 - C. -17.566×10^{-3} V
 - D. -30.575×10^{-3} V
 - E. -48.431×10^{-3} V
9. A rod of mass 0.47 kg and length 0.2 m is placed in U shaped conductor (with its open end to the right) placed in a region where there is a magnetic field of strength 0.61 T which is perpendicular to the plane of the conductor. The resistance of the rod is 30Ω . If the rod is pushed to the right with an initial velocity of 10 m/s, then the velocity of the rod after 4.2 seconds is
- A. 12.43 m/s
 - B. 1.429 m/s
 - C. 13.512 m/s
 - D. 7.305 m/s
 - E. 9.956 m/s

10. A solenoid of length 0.055 m, radius 0.03 and number of turns 170 is carrying a current of 2.3 A. A circular loop of radius 0.1 m is placed around the solenoid. If the current in the solenoid is reduced to zero in 0.065 seconds, calculate the average emf induced in the loop.

- A. 3.886×10^{-4} V
 B. 3.256×10^{-4} V
 C. 5.964×10^{-4} V
 D. 2.811×10^{-4} V
 E. 4.305×10^{-4} V

Expressing Faraday's law in terms of electric field

Induced voltage due to rate of change of magnetic flux is an \mathcal{E} because it is voltage created by converting non-electrical energy to electrical energy. \mathcal{E} is defined to be work done by the source per a unit charge $\left(\mathcal{E} = \frac{W}{q} \right)$ and the work done by the source is given by $W_s = q \int \vec{E} \cdot d\vec{s}$ where \vec{E} is electric field due to the source. Thus, $\frac{W_s}{q} = \frac{q \int \vec{E} \cdot d\vec{s}}{q} = \int \vec{E} \cdot d\vec{s}$. Therefore, for a closed loop, Faraday's law can be written as

$$\mathcal{E} = \oint \vec{E} \cdot d\vec{s} = -\frac{d\phi_B}{dt}$$

From Faraday's law, we see that the electric field due to a source (as opposed to due to a charge) is not conservative. Because if it was conservative, the integral of the electric field over a closed path would be zero.

Example: Consider a solenoid of length ℓ , number of turns N and radius R . It carries a current I which varies as a function of time. Obtain an expression for the electric field at a point a perpendicular distance r_{\perp} from the axis of the solenoid where $r_{\perp} > R$.

Solution: From symmetry the following conclusion can be made: a) the electric field lines should be circles concentric with the axis of the solenoid. b) the magnitude of the electric field at points on a circle concentric with the axis of the solenoid should be constant. Let's choose our path for applying Faraday's law to be a circle concentric with the axis of the solenoid of radius $r_{\perp} > R$. $d\vec{s} = ds\hat{e}_{\phi}$ and $\vec{E} = E_s\hat{e}_{\phi}$ where \hat{e}_{ϕ} is a counterclockwise tangential unit vector and E_s is a component of the electric field in the direction of \hat{e}_{ϕ} . $\vec{E} \cdot d\vec{s} = E_s ds$ and the magnetic flux $\phi_B = B_s A = \pi R^2 B_s = \pi R^2 \left(\frac{\mu_0 NI}{\ell} \right)$. Now applying Faraday's law $\oint \vec{E} \cdot d\vec{s} = E_s \oint ds = 2\pi r_{\perp} E_s = -\frac{d\phi_B}{dt} = -\frac{\mu_0 N \pi R^2}{\ell} \frac{dI}{dt}$ which implies $E_s = -\frac{\mu_0 N R^2}{2r_{\perp}} \frac{dI}{dt}$. Therefore the vector electric field is given as

$$\vec{E} = -\frac{\mu_0 N R^2}{2r_{\perp}} \frac{dI}{dt} \hat{e}_{\phi}$$

Need help with your dissertation?

Get in-depth feedback & advice from experts in your topic area. Find out what you can do to improve the quality of your dissertation!

Get Help Now



Go to www.helpmyassignment.co.uk for more info



The electric field is proportional to the rate of change of current with time. In using this formula the current should be taken to be positive (negative) if the current is flowing counterclockwise (clockwise). If the current is flowing counterclockwise, the direction of the electric field will be clockwise (counterclockwise) if the current is increasing (decreasing). If the current is flowing clockwise, the direction of the electric field will be counterclockwise (clockwise) if the current is increasing (decreasing).

Lenz's Rule

Lenz's rule states that the direction of the induced current is in such a way as to oppose the cause. If the cause of the induced current is an increase (decrease) of magnetic flux, the direction of the induced current will be in such a way as to decrease (increase) the magnetic flux. For example if an increase in magnetic field is the cause for the increase in magnetic flux, then the direction of the induced current should be in such a way that its induced field opposes the external field so that the magnetic flux decreases.

Example: A U-shaped conductor with its open end to the right is placed in a magnetic field that penetrates its plane perpendicularly out. A rod is sliding on the U-shaped conductor to the right by means of an external force. The change in area of the loop formed by the rod and the closed end of the U-shaped conductor will result in induced emf and hence induced current.

a) What is the cause for the change in flux?

Solution: The cause for the change in flux is the external force pulling the rod to the right causing change in area.

b) There will be an induced current in the rod as the rod is moving. A current carrying rod placed in a magnetic field is acted upon by a magnetic force. What should the direction of this force be?

Solution: According to Lenz's rule, the direction of the induced current should be in such a way as to oppose the cause. The cause is the external force to the right. Therefore the direction of the induced current must be in such a way that the direction of the magnetic force is to the left so that it opposes the external force.

c) Is the induced current flowing down or up the rod?

Solution: Since the magnetic force is to the left and the field is perpendicularly out, from the screw rule or the right hand rule, the induced current must be flowing down the rod (as a screw is turned from the direction of the induced current (down the rod) towards the field (perpendicularly out), it goes to the left.).

Example: A loop is pulled away to the right from the north pole of a permanent magnet.

a) What is the cause for the change in magnetic flux crossing the loop?

Solution: As the loop is pulled away, the strength of the magnetic field crossing it decreases because it is getting further and further from the magnet. Thus, the cause for the change of flux is the decrease in magnetic field.

b) The change in the flux crossing the loop will produce induced current in the loop and this induced current will produce its own induced field. What should the direction of this induced field be.

Solution: According to Lenz's rule, the direction of the induced current is in such a way as to oppose the cause. Since the cause is decrease in magnetic field, the direction of the induced current must be in such a way as to increase the field. To increase the field, the induced field should be parallel to the field due to the permanent magnet. The field due to the permanent magnet is to the right since magnetic field lines come out of the North Pole. Therefore the direction of the induced field must be to the right.

c) As seen from the right of the loop, is the induced current flowing clockwise or counter clockwise.

Solution: From the right hand rule for solenoids, when thumb points to the right, fingers are wrapped in a counter clockwise direction when seen from the right. Therefore the induced current is flowing in a counter clockwise direction as seen from the right.

Example: A loop is pushed towards the north pole of a magnet. The North Pole is located on the right end of the magnet.

a) What is the cause for the change of flux and hence induced current in the loop?

Solution: As the loop is pushed towards the magnet, the strength of the magnetic field crossing the loop gets stronger and stronger because the loop is getting nearer and nearer. Therefore the cause for the induced current is an increase in the strength of the field.

b) The induced current in the loop will produce its own induced magnetic field. What should the direction of the induced field be?

Solution: Since the cause is an increase in magnetic field, according to Lenz's rule, the direction of the induced current must be in such a way as to decrease the field. To decrease the field, the induced field should oppose the field due to the permanent magnet. The direction of the field due to the permanent magnet is to the right (magnetic field lines come out of the North Pole). Therefore the direction of the induced field must be to the left.



Brain power

By 2020, wind could provide one-tenth of our planet's electricity needs. Already today, SKF's innovative know-how is crucial to running a large proportion of the world's wind turbines.

Up to 25 % of the generating costs relate to maintenance. These can be reduced dramatically thanks to our systems for on-line condition monitoring and automatic lubrication. We help make it more economical to create cleaner, cheaper energy out of thin air.

By sharing our experience, expertise, and creativity, industries can boost performance beyond expectations. Therefore we need the best employees who can meet this challenge!

The Power of Knowledge Engineering

Plug into The Power of Knowledge Engineering.
Visit us at www.skf.com/knowledge

SKF

c) As seen from the right, is the induced current in the loop flowing clockwise or counter clockwise.

Solution: Using the right hand rule for solenoids, when thumb points left fingers are wrapped in a clockwise direction as seen from the right. The induced current is flowing in a clockwise direction as seen from the right.

Example: A loop is put around a solenoid. The solenoid (whose axis is horizontal) carries a current in a clockwise direction as seen from the right. The current is turned off suddenly. As a result there will be a temporary flow of induced current in the loop surrounding the solenoid.

a) What is the cause for the induced current?

Solution: As the current is turned off, the field due to the solenoid suddenly drops to zero. Therefore the cause for the induced current is the decrease of the magnetic field crossing the loop.

b) What should be the direction of the induced field due to the induced current in the solenoid?

Solution: Since the cause is decrease of magnetic field, the direction of the induced current must be in such a way as to increase the field. To increase the field, the induced field should have the same direction as the field due to the solenoid. From the right hand rule, the field due to the solenoid is to the left (When fingers are wrapped in a clockwise direction as seen from the right, thumb points to the left). Therefore, the direction of the induced field should be to the left.

c) As seen from the right, is the induced current in the loop flowing clockwise or counter clockwise.

Solution: Applying the right hand rule, when thumb points to the left, fingers are wrapped in a clockwise direction as seen from the right. Thus, the current is flowing clockwise as seen from the right.

Maxwell's Equations

The four equations governing electricity and magnetism discussed so far are called Maxwell's equations.

- 1) *Gauss's law for electric field*: The surface integral of the electric field on any closed surface is equal to the total charge inside the closed surface divided by the electric permittivity of vacuum (ϵ_0).

$$\oint_{\text{closed surface}} \vec{E} \cdot d\vec{A} = \frac{q}{\epsilon_0}$$

- 2) *Gauss's law for magnetic field*: The surface integral of the magnetic field over any closed surface is equal to zero.

$$\oint_{\text{closed surface}} \vec{B} \cdot d\vec{A} = 0$$

- 3) *Ampere-Maxwell law*: The line integral of the magnetic field along any closed loop is equal to μ_0 times the total current and the total displacement current $\left(\epsilon_0 \frac{d\phi_E}{dt} \right)$ crossing the loop.

$$\oint \vec{B} \cdot d\vec{s} = \mu_0 \left(I + \epsilon_0 \frac{d\phi_E}{dt} \right)$$

It is called Ampere-Maxwell law, because the displacement current was theoretically predicted by Maxwell himself.

- 4) *Faraday's Law*: The line integral of the electric field in any closed path is equal to the negative rate of change of the magnetic flux crossing the loop with time.

$$\oint \vec{E} \cdot d\vec{s} = - \frac{d\phi_B}{dt}$$

Practice Quiz 9.2

Choose the best answer

1. The Electric field in a certain region varies according to the equation $E = 11.3/r^{0.75} \mathbf{e}_0$. Calculate the rate of change of the magnetic flux that crosses a circular surface of radius 0.83 m centered at the origin.
A. $-67.768 \text{ A m}^2/\text{s}$
B. $67.768 \text{ A m}^2/\text{s}$
C. 0
D. $25.908 \text{ A m}^2/\text{s}$
E. $-25.908 \text{ A m}^2/\text{s}$
2. A solenoid of length 0.085 m, radius 0.05 and number of turns 180 is carrying a current that varies with time as $i(t) = 6.4/t$. Calculate the electric field at a perpendicular distance (from the axis of the solenoid) of 0.15 m after 3.2 seconds.
A. $26.283e-6 \text{ N/C}$
B. $15.534e-6 \text{ N/C}$
C. $5.149e-6 \text{ N/C}$
D. $13.86e-6 \text{ N/C}$
E. $22.365e-6 \text{ N/C}$



What do you want to do?

No matter what you want out of your future career, an employer with a broad range of operations in a load of countries will always be the ticket. Working within the Volvo Group means more than 100,000 friends and colleagues in more than 185 countries all over the world. We offer graduates great career opportunities – check out the Career section at our web site www.volvogroup.com. We look forward to getting to know you!

VOLVO
AB Volvo (publ)
www.volvogroup.com

VOLVO TRUCKS | RENAULT TRUCKS | MACK TRUCKS | VOLVO BUSES | VOLVO CONSTRUCTION EQUIPMENT | VOLVO PENTA | VOLVO AERO | VOLVO IT
VOLVO FINANCIAL SERVICES | VOLVO 3P | VOLVO POWERTRAIN | VOLVO PARTS | VOLVO TECHNOLOGY | VOLVO LOGISTICS | BUSINESS AREA ASIA

3. If the cause for an induced current in a loop is an increase in magnetic field, then the direction of the induced current will be in such a way as to
 - A. None of the other choices are correct.
 - B. increase the magnetic field
 - C. eliminate the magnetic field
 - D. All of the other choices are correct.
 - E. decrease the magnetic field

4. A U shaped conductor is placed in a region where there is magnetic field directed perpendicularly out of the plane of the loop. When a conducting rod slides on the U shaped conductor to the right, then the direction of the magnetic force acting on the rod due to the induced current is
 - A. up
 - B. to the left
 - C. down
 - D. to the right
 - E. none of the other choices are correct

5. A U shaped conductor is placed (with its open end to the right) in a region where there is a magnetic field directed perpendicularly into the plane of the loop. When a conducting rod slides to the left, the direction of the induced current is
 - A. down the rod (south)
 - B. there is no current
 - C. up the rod (south)
 - D. none of the other choices are correct
 - E. all of the other choices are correct

6. A permanent magnet is placed horizontally with the right end being its South Pole. A conducting loop is pushed to the left towards the South Pole. The direction of the induced magnetic field due to the induced current in the loop is
 - A. cannot be determined
 - B. there is no induced field
 - C. to the right
 - D. to the left
 - E. None of the other choices are correct.

7. A permanent magnet is placed horizontally with the right end being its South Pole. A conducting loop is pulled away from the right end to the right. The direction of the induced current in the loop as seen from the right of the loop is
- A. there is no induced current
 - B. clockwise
 - C. None of the other choices are correct.
 - D. counter-clockwise
 - E. cannot be determined
8. A solenoid is placed horizontally. The current in the solenoid is clockwise as seen from the right end. A conducting loop is wrapped around the solenoid (concentric with the solenoid). If the current is increased, the direction of the induced magnetic field due to the induced current in the loop is
- A. to the left
 - B. to the right
 - C. None of the other choices are correct.
 - D. there is no induced field
 - E. cannot be determined
9. A solenoid is placed horizontally. The current in the solenoid is clockwise as seen from the right end. A conducting loop is wrapped around the solenoid (concentric with the solenoid). If the current is decreased, the direction of the induced current in the loop as seen from the right is
- A. there is no induced current
 - B. None of the other choices are correct.
 - C. cannot be determined
 - D. counter-clockwise
 - E. clockwise
10. Which of the following is a statement of Gauss's law?
- A. The total electric flux crossing any closed surface is proportional to the total charge enclosed inside the closed surface.
 - B. The line integral of the electric field along any closed path is proportional to the rate of change of the magnetic flux crossing any surface area bounded by the path.
 - C. The total electric flux crossing any closed surface is proportional to the rate of change of the magnetic flux crossing the closed surface .
 - D. The line integral of the magnetic field along any closed path is proportional to the total current (conduction and displacement current) crossing any surface area bounded by the path.
 - E. The total magnetic flux crossing any closed surface is proportional to the total charge enclosed inside the closed surface.

10 INDUCTANCE

Your goal for this chapter is to learn about self-induced emf, mutual induction, RL circuit, LC circuit and RLC circuit.

Self-Induced emf of an inductor

An *inductor* is a coil. The circuit symbol for an inductor is a coil. When an inductor is connected to a source, current will flow through it and this current will produce magnetic field inside the coil. That is there is magnetic flux crossing the loops of the coil due to its own magnetic field. If the current changes with time, then the magnetic field inside the coil will change with time which implies the magnetic flux crossing the coil will change with time. According to Faraday's law, this change in magnetic flux will produce induced emf in the coil. This kind of induced emf is called self induced emf (\mathcal{E}_{self}) because it is caused by the current in the coil itself.

gaiTeye[®]
Challenge the way we run

**EXPERIENCE THE POWER OF
FULL ENGAGEMENT...**

**RUN FASTER.
RUN LONGER..
RUN EASIER...**

**READ MORE & PRE-ORDER TODAY
WWW.GAITEYE.COM**

Since the magnetic field due to a coil (solenoid) is proportional to the current flowing in the coil, the magnetic flux crossing the coils is proportional to the current. The constant of proportionality between the flux (ϕ_{self}) and the current is defined to be the inductance (L) of the coil:

$$\phi_{self} = LI$$

According to Faraday's Law, the self-induced emf (\mathcal{E}_{self}) is equal to the negative rate of change of this flux with time.

$$\mathcal{E}_{self} = -L \frac{dI}{dt}$$

The negative sign indicates that the polarity of the self-induced emf is in such a way as to oppose the cause for the change in flux which is the rate of change of current with time. (It essentially represents Lenz's rule). The unit of measurement for inductance is V/A/s which is defined to be the Henry, abbreviated as H. The average induced emf in a given time interval

Δt can be obtained by integrating \mathcal{E}_{self} with time in a time interval Δt and then dividing by Δt : $\bar{\mathcal{E}}_{self} = -\frac{L}{\Delta t} \int_t^{t+\Delta t} \frac{dI}{dt} dt = -\frac{L}{\Delta t} \int_{I_i}^{I_f} dI$ and the average self induced emf may be given as

$$\bar{\mathcal{E}}_{self} = -L \frac{\Delta I}{\Delta t} = -L \frac{(I_f - I_i)}{\Delta t}$$

Example: The current in an inductor of inductance 5H varies with time according to the equation $I = 2\sin 10t$ A.

a) Give a formula for the self-induced emf as a function of time.

Solution:

$$L = 5 \text{ H}; \mathcal{E}_{self}(t) = ?$$

$$\mathcal{E}_{self} = -L \frac{dI}{dt} = -5 \frac{d}{dt}(2\sin 10t) \text{ V} = -100 \cos 10t \text{ V}$$

b) Calculate the value of the induced emf after $\frac{\pi}{40}$ s.

Solution:

$$\mathcal{E}_{self}(t) = -100 \cos 10t$$

$$\mathcal{E}_{self}\left(t = \frac{\pi}{40}\right) = -100 \cos\left(10 \frac{\pi}{40}\right) \text{ V} = -70 \text{ V}$$

Example: The current in a 2 mH inductor changed from 10 A to 4 A in 0.2 seconds. Calculate the average self-induced emf in the inductor?

Solution:

$$L = 2 \text{ mH}; I_i = 10 \text{ A}; I_f = 4 \text{ A}; \Delta t = 0.2 \text{ s}; \bar{\mathcal{E}}_{self} = ?$$

$$\bar{\mathcal{E}}_{self} = -L \frac{(I_f - I_i)}{\Delta t} = -2 \times 10^{-3} \left(\frac{4 - 10}{0.2}\right) \text{ V} = 0.06 \text{ V}$$

Inductance of a Solenoid in terms of its geometry

The inductance of an inductor depends on the geometry of the coil only. Consider a solenoid of length ℓ , radius R and number of turns N . The magnetic flux crossing the solenoid is N times the flux crossing a single turn: $\phi_{self} = NBA$. But $A = \pi R^2$ and $B = \frac{\mu_0 NI}{\ell}$ for a solenoid. Therefore since $L = \frac{N\phi_{self}}{I}$, the inductance of a solenoid in terms of its geometry is given as

$$L = \frac{\mu_0 N^2 \pi R^2}{\ell}$$

Magnetic Energy Stored by an inductor

Consider an inductor connected to a source. According to Lenz's rule, the self-induced emf should oppose the source because it is the cause for the change of flux. Therefore the source has to do work to push a charge through the inductor. This work is stored by the inductor as magnetic energy. The work done by the source in pushing a charge dq across the inductor is $dw_{ext} = -dq \varepsilon_{self}$. The negative sign is needed because the work done by the external force (source) is opposite to the work done by the self-induced emf. But $\varepsilon_{self} = -L \frac{dI}{dt}$ and $dw_{ext} = -dq \left(-L \frac{dI}{dt}\right) = L \frac{dq}{dt} dI = LI dI$. The amount of magnetic energy (U_B) stored by the inductor when the current is increased from zero to a value I is obtained by integration: $U_B = \int dw_{ext} = \int_0^I LI' dI'$. Therefore the amount of magnetic energy stored by an inductor when the current is I is given by

$$U_B = \frac{1}{2} LI^2$$

This e-book
is made with
SetaPDF



PDF components for PHP developers

www.setasign.com



Magnetic energy density inside a current carrying Solenoid

Consider a solenoid of N turns, length ℓ and cross-sectional radius R carrying a current I . The magnetic energy density (u_B) inside a solenoid is obtained as the ratio of the total magnetic energy ($U_B = \frac{1}{2}LI^2$) to the volume of the solenoid ($V = \pi R^2\ell$): $u_B = \frac{U_B}{V} = \frac{LI^2}{2\pi R^2\ell}$. But, as shown earlier, the inductance of a solenoid is given as $L = \frac{\mu_0 N^2 \pi R^2}{\ell}$; and the magnetic field inside a solenoid is given as $B = \frac{\mu_0 NI}{\ell}$ which implies $I = \frac{B\ell}{\mu_0 N}$. Now, with these substitutions for the inductance and the current, the magnetic energy density depends on the magnetic field according to the equation

$$u_B = \frac{B^2}{2\mu_0}$$

Example: A solenoid of length 10 cm, number of turns 200 and cross-sectional radius 2 cm is carrying a current of 2A.

a) Calculate the magnetic energy density inside the solenoid.

Solution:

$\ell = 0.1$ m; $R = 0.02$ m; $N = 200$; $I = 2$ A; $u_B = ?$

$$B = \frac{\mu_0 NI}{\ell} = \frac{(4\pi \times 10^{-7})(200)(2)}{0.1} \text{ T} = 16\pi \times 10^{-4} \text{ T}$$

$$u_B = \frac{B^2}{2\mu_0} = \frac{(16\pi \times 10^{-4})^2}{2(4\pi \times 10^{-7})} \text{ J/m}^3 = 3.2\pi \text{ J/m}^3$$

b) Calculate the total magnetic energy stored inside the solenoid.

Solution:

$U_B = ?$

$$U_B = u_B V = u_B (\pi R^2 \ell) = 3.2\pi (\pi \times 0.02^2 \times 0.1) \text{ J} = 1.26 \times 10^{-3} \text{ J}$$

A series combination of an inductor and a resistor connected to a dc source

Consider a battery of emf ε connected to a series combination of a resistor of resistance R and an inductor of inductance L . An inductor behaves like a resistor when its current increases (gaining magnetic energy at the expense of electrical energy) and behaves like a source when current decreases (losing magnetic energy to create electrical energy). Therefore, both resistor and source sign conventions apply depending on the situation. If traversed in the direction of the current, the potential difference in both cases is $-L \frac{dI}{dt}$. The difference between resistor and source behavior is contained in the sign of $\frac{dI}{dt}$. Now applying Kirchhoff's rule in the direction of the current

$$\varepsilon - L \frac{dI}{dt} - IR = 0$$

Rearranging, this equation may be written as $\frac{dI}{dt} = \frac{\varepsilon - IR}{L}$ or $dI = \frac{\varepsilon - IR}{L} dt$. Integrating, $\int_0^I \frac{dI'}{\varepsilon - IR'} = \int_0^t \frac{dt'}{L}$ (The initial current is zero). Let $u = \varepsilon - I'R$. Then $du = -RdI'$, $u(t=0) = \varepsilon$ and $u(t) = \varepsilon - IR$. With this substitution the integral becomes $-\frac{1}{R} \int_{\varepsilon}^{\varepsilon - IR} \frac{du}{u} = \frac{t}{L}$ which implies that $\ln\left(\frac{\varepsilon - IR}{\varepsilon}\right) = -\frac{R}{L}t$ or $\varepsilon - IR = \varepsilon e^{-\frac{R}{L}t}$. And solving for the current the following expression for the current as a function of time is obtained.

$$I(t) = \frac{\varepsilon}{R} \left(1 - e^{-\frac{R}{L}t}\right)$$

The current attains its maximum value at infinity: $I_{\max} = \frac{\varepsilon}{R} \lim_{t \rightarrow \infty} \left(1 - e^{-\frac{R}{L}t}\right) = \frac{\varepsilon}{R}$. The current approaches its maximum value asymptotically with time. The expression $\frac{R}{L}$ determines how fast the current approaches its maximum value and is called the time constant of the circuit. The greater the time constant the faster the current approaches its maximum value. The potential difference across the resistor is equal to current times its resistance:

$$V_R(t) = \varepsilon \left(1 - e^{-\frac{R}{L}t}\right)$$

The potential difference across the resistor is zero initially and approaches the emf of the battery asymptotically as time approaches infinity. The self-induced emf of the inductor can be obtained as $\varepsilon_{self} = -L \frac{dI}{dt} = -L \frac{d}{dt} \left\{ \frac{\varepsilon}{R} \left(1 - e^{-\frac{R}{L}t} \right) \right\}$ which gives the following expression for the dependence of the emf:

$$\varepsilon_{self}(t) = -\varepsilon e^{-\frac{R}{L}t}$$

The self-induced emf has its maximum value initially and approaches zero asymptotically as time approaches infinity. Adding the potential difference and the self-induced voltage shows that it is always equal $-\varepsilon$ as expected: $-V_R + \varepsilon_{self} = -\varepsilon \left(1 - e^{-\frac{R}{L}t} \right) - \varepsilon e^{-\frac{R}{L}t} = -\varepsilon$.

Example: A series combination of a 1000Ω resistor and a 20 H inductor is connected to a battery of emf 20V .

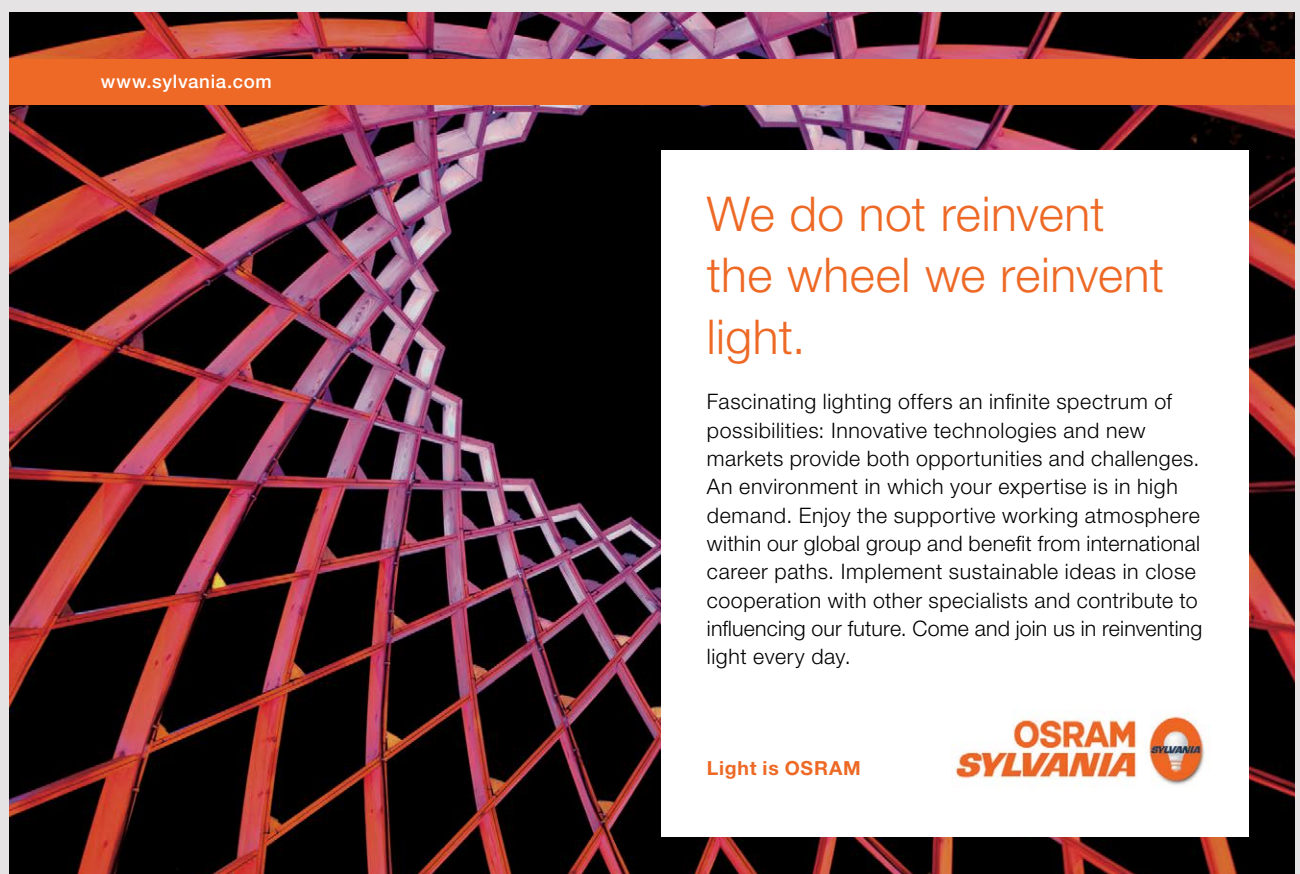

www.sylvania.com

We do not reinvent
the wheel we reinvent
light.

Fascinating lighting offers an infinite spectrum of possibilities: Innovative technologies and new markets provide both opportunities and challenges. An environment in which your expertise is in high demand. Enjoy the supportive working atmosphere within our global group and benefit from international career paths. Implement sustainable ideas in close cooperation with other specialists and contribute to influencing our future. Come and join us in reinventing light every day.

Light is OSRAM

OSRAM
SYLVANIA

a) Calculate the maximum current.

Solution:

$$R = 1000 \, \Omega; \, \varepsilon = 20; \, I_{\max} = ?$$

$$I_{\max} = \frac{\varepsilon}{R} = \frac{20}{1000} \, \text{A} = 0.02 \, \text{A}$$

b) Calculate the time taken for the current to reach a value one fourth of its maximum value.

Solution:

$$I = \frac{\varepsilon}{R} \left(1 - e^{-\frac{R}{L}t} \right) = \frac{\varepsilon}{4R}$$

$$1 - e^{-\frac{R}{L}t} = \frac{1}{4}$$

$$e^{-\frac{R}{L}t} = \frac{3}{4}$$

$$-\frac{R}{L}t = \ln\left(\frac{3}{4}\right)$$

$$t = -\frac{L}{R} \ln\left(\frac{3}{4}\right) = -\frac{20}{1000} \ln\left(\frac{3}{4}\right) \, \text{s} = 0.00575 \, \text{s}$$

Practice Quiz 10.1

Choose the best answer

- Which of the following is a correct statement?
 - The SI unit of measurement of inductance is Ohm
 - The self-induced emf of an inductor is proportional to the current in the inductor.
 - The inductance of an inductor is proportional to the magnetic flux crossing the inductor per a unit current
 - The inductance of an inductor is proportional to the current in the inductor.
 - An inductor stores energy in the form of electrical energy.
- When the current in an inductor changes from 13 A to 12 A in 0.34 s, 5 V of average voltage is induced. Calculate the inductance of the inductor.
 - 1.7 H
 - 0.859 H
 - 2.556 H
 - 1.306 H
 - 1.938 H

3. The current in a solenoid of inductance $5.4e-3$ H, varies with time according to the equation $I(t) = 2.7 \sin(12.7t)$ A. Calculate the self-induced voltage after $2.6e-3$ seconds.
- A. $-23.83e-2$ V
 - B. $-15.348e-2$ V
 - C. $-18.507e-2$ V
 - D. $-2.027e-2$ V
 - E. $-34.228e-2$ V
4. A solenoid has a length of 0.13 m and a cross-sectional radius of $4.6e-2$ m. If it has 350 turns, calculate its inductance.
- A. $4.741e-3$ H
 - B. $11.816e-3$ H
 - C. $10.711e-3$ H
 - D. $14.327e-3$ H
 - E. $7.872e-3$ H
5. A solenoid has a length of 0.074 m and a cross-sectional radius of $7.2e-2$ m. If it has 250 turns, calculate the magnetic energy stored by the solenoid when a current of 2.6 A is flowing through it.
- A. $39.368e-3$ J
 - B. $58.424e-3$ J
 - C. $26.021e-3$ J
 - D. $109.809e-3$ J
 - E. $49.993e-3$ J
6. A solenoid has a length of 0.074 m and a cross-sectional radius of $1.8e-2$ m. It has 225 turns. If the magnetic field inside the solenoid is measured to be $2.6e-3$ T, calculate the magnetic energy density inside the solenoid.
- A. 2.413 J/m³
 - B. 5.079 J/m³
 - C. 2.69 J/m³
 - D. 1.221 J/m³
 - E. 3.404 J/m³

7. Which of the following statements is a correct statement?
- A. The greater the time constant of a series RL circuit connected to a DC source, the slower the current of the circuit approaches a steady value
 - B. When a series combination of a resistor of resistance R and inductor of inductance L is connected to a battery of emf E , then the current can be obtained as a solution of the differential equation $dI/dt - (R/L)I + E/L = 0$
 - C. When a series RL circuit is connected to a DC source, as time increases, the rate of change of current decreases to a steady value asymptotically.
 - D. When a series RL circuit is connected to a DC source, the current is a constant independent of time
 - E. When a series RL circuit is connected to a DC source, as time increases, the current decreases to a steady value asymptotically
8. A series combination of a 512Ω resistor and a 18 H inductor is connected to a 40 V battery. Calculate the time constant of the circuit.
- A. $35.74 \Omega / \text{H}$
 - B. $5.525 \Omega / \text{H}$
 - C. $28.444 \Omega / \text{H}$
 - D. $40.707 \Omega / \text{H}$
 - E. $14.723 \Omega / \text{H}$



Discover the truth at www.deloitte.ca/careers

Deloitte.

© Deloitte & Touche LLP and affiliated entities.

9. For a certain series RL circuit connected to a DC source, the voltage across the resistor rises to $(1/6)^{th}$ of the maximum voltage across the resistor in a time interval of $1.2e-3$ seconds. Calculate the time constant of the circuit.
- A. $151.935 \Omega/H$
 B. $265.798 \Omega/H$
 C. $229.099 \Omega/H$
 D. $40.344 \Omega/H$
 E. $180.141 \Omega/H$
10. A series combination of a 965Ω resistor and a $25 H$ inductor is connected to a $60 V$ battery. Calculate the current in the circuit after a time interval of $1.7e-3$ seconds.
- A. $2.115e-3 A$
 B. $3.949e-3 A$
 C. $3.231e-3 A$
 D. $2.83e-3 A$
 E. $4.578e-3 A$

Mutual Induction

When two coils carrying time dependent currents are in the vicinity of each other, they will induce on each other. This kind of induction is called *mutual induction*. The flux induced by one on the other is proportional to the current in the former. Consider two coils, coil 1 & coil 2, in the vicinity of each other. The mutual inductance of coil 2 with respect to coil 1 (M_{21}) is defined to be the ratio between the flux crossing coil 2 due to the current in coil 1 and the current in coil 1 (I_1). If the number of turns of coil 2 is N_2 and the magnetic flux per coil crossing coil 2 is ϕ_{12} , then

$$M_{21} = \frac{N_2 \phi_{21}}{I_1}$$

Similarly, the mutual inductance of coil 1 with respect to coil 2 is defined to be $M_{12} = \frac{N_1 \phi_{12}}{I_2}$.

It can be shown that $M_{12} = M_{21} = M$ where M is called the mutual inductance of the coils;

$$\text{That is } M = \frac{N_1 \phi_{12}}{I_2} = \frac{N_2 \phi_{21}}{I_1}.$$

Applying Faraday's law, the emf induced in coil 2 (\mathcal{E}_2) is given by $\mathcal{E}_2 = -N_2 \frac{d\phi_{21}}{dt}$. But $\phi_{21} = \frac{MI_1}{N_2}$ and it follows that

$$\mathcal{E}_2 = -M \frac{dI_1}{dt}$$

The emf induced on coil 2 by coil 1 is directly proportional to the rate of change of the current flowing in coil 1. Similarly, the emf induced on coil 1 by coil 2 is given as $\mathcal{E}_1 = -M \frac{dI_2}{dt}$.

Mutual Inductance of Two Concentric Solenoids of the same Length

Consider two concentric solenoids with the inner solenoid being coil 1 and the outer being coil 2.

The magnetic flux induced on solenoid 1 by solenoid 2 is $\phi_{12} = B_2 A_1 = \left(\frac{\mu_0 N_2 I_2}{\ell} \right) A_1$. Therefore the mutual inductance of solenoid 1 with respect to solenoid 2 is $M = M_{12} = \frac{N_2 \phi_{12}}{I_2}$ which simplifies to

$$M = \frac{\mu_0 N_1 N_2 A_1}{\ell}$$

A charged Capacitor Connected to an inductor

The sign convention for an inductor has already been stated in the previous section. A capacitor behaves like a resistor when losing charge (or losing electrical energy) and behaves like a source when it is being charged (that is gaining electrical energy). So both resistor and source sign conventions apply depending in the situation. In both cases, if the capacitor is transversed in the direction of the current, the potential difference is given as $-\frac{Q}{C}$. Now, applying Kirchhoff's loop rule, $-\frac{Q}{C} - L \frac{dI}{dt} = 0$. With $I = \frac{dQ}{dt}$ (and some rearranging), the charge stored in the capacitor satisfies the differential equation

$$\frac{d^2 Q}{dt^2} + \frac{1}{LC} Q = 0$$

The general solution of this differential equation is $Q = C_1 \cos\left(\sqrt{\frac{1}{LC}} t + C_2\right)$ where C_1 and C_2 are arbitrary constant to be determined from two initial (or other) conditions. Let the initial charge of the capacitor be Q_{\max} . Then $Q(t=0) = C_1 \cos\left(\sqrt{\frac{1}{LC}} (0) + C_2\right) = Q_{\max}$ or $Q_{\max} = C_1 \cos(C_2)$ or The current is given by $I = \frac{dQ}{dt} = -\frac{C_1}{\sqrt{LC}} \sin\left(\sqrt{\frac{1}{LC}} t + C_2\right)$. The initial current is zero. Therefore $I(t=0) = -\frac{C_1}{\sqrt{LC}} \sin\left(\sqrt{\frac{1}{LC}} (0) + C_2\right) = 0$ or $0 = -\frac{C_1}{\sqrt{LC}} \sin(C_2)$ which implies $C_2 = 0$ (the possibility $C_1 = 0$ is avoided because it implies zero charge). With $C_2 = 0$, it follows that $C_1 = Q_{\max}$ and the solutions for the charge and current as a function of time are respectively given as

$$Q(t) = Q_{\max} \cos\left(\frac{1}{\sqrt{LC}} t\right)$$

$$I(t) = -\frac{Q_{\max}}{\sqrt{LC}} \sin\left(\frac{1}{\sqrt{LC}} t\right)$$

SIMPLY CLEVER

ŠKODA



We will turn your CV into
an opportunity of a lifetime



Do you like cars? Would you like to be a part of a successful brand?
We will appreciate and reward both your enthusiasm and talent.
Send us your CV. You will be surprised where it can take you.

Send us your CV on
www.employerforlife.com



Download free eBooks at bookboon.com

Click on the ad to read more

The coefficient of time $\left(\frac{1}{\sqrt{LC}}\right)$ represents the angular frequency (number of radians executed per second) and is denoted by ω_0 .

$$\omega_0 = \frac{1}{\sqrt{LC}}$$

The frequency (f_0) (Number of cycles per second) is related with angular frequency by $\omega_0 = 2\pi f_0$ (since there are 2π radians in a cycle) and is given as $f_0 = \frac{1}{2\pi} \sqrt{\frac{1}{LC}}$. The period (time taken for one cycle) is the inverse of the frequency: $T_0 = 2\pi\sqrt{LC}$.

Example: A 20 F capacitor is connected to a 10 V battery. Then it is disconnected from the battery and connected to a 5 H inductor. Then it is disconnected from the battery and connected to a 5 H inductor.

a) Calculate the maximum charge of the capacitor.

Solution:

$$C = 20 \text{ F}; \Delta V = 10 \text{ V}; Q_{\max} = ?$$

$$Q_{\max} = CV = (20)(10) \text{ C} = 200 \text{ C}$$

b) Calculate the angular frequency of the circuit.

Solution:

$$L = 5 \text{ H}; \omega_0 = ?$$

$$\omega_0 = \frac{1}{\sqrt{LC}} = \frac{1}{\sqrt{5 \times 20}} \text{ rad/s} = 0.1 \text{ rad/s}$$

c) How many cycles does the circuit execute per second.

Solution:

$$f_0 = ?$$

$$f_0 = \frac{\omega_0}{2\pi} = \frac{0.1}{2\pi} \text{ Hz} = \frac{1}{20\pi} \text{ Hz}$$

d) Calculate the time taken for one cycle

Solution:

$$T_0 = ?$$

$$T_0 = \frac{1}{f_0} = 20\pi \text{ s}$$

e) Give expressions for the charge and current as a function of time.

$$Q = Q_{\max} \cos(\omega_0 t) = 200 \cos(0.1 t) \text{ C}$$

$$I = -\frac{Q_{\max}}{\sqrt{LC}} \sin\left(\frac{1}{\sqrt{LC}} t\right) = -20 \sin(0.1 t) \text{ A}$$

Energy of an LC Circuit

From Kirchoff's loop rule $L \frac{dI}{dt} = -\frac{Q}{C}$. Multiplying both sides by dQ , $LdI \frac{dQ}{dt} = -\frac{Q}{C} dQ$. Replacing $\frac{dQ}{dt}$ by I results in $LIdI = -\frac{Q}{C} dQ$. Integrating this equation gives $\frac{1}{2} LI^2 + \frac{1}{2} \frac{Q^2}{C} = c$ where c stands for an integration constant. But the expressions $\frac{1}{2} LI^2$ and $\frac{1}{2} \frac{Q^2}{C}$ represent the magnetic energy stored in the inductor and the electrical energy stored in the capacitor respectively. Therefore it follows that the sum of the electrical energy in the capacitor and the magnetic energy stored in the inductor is a constant independent of time and should be equal to the initial electrical energy in the capacitor ($\frac{Q_{\max}^2}{2C}$). That is,

$$U_{em} = \frac{1}{2} LI^2 + \frac{1}{2} \frac{Q^2}{C} = \frac{Q_{\max}^2}{2C}$$

Where U_{em} stands for the total energy stored in the LC circuit. The process involves only the interchange between electrical and magnetic energy.

Example: A $16F$ capacitor is connected to an $8V$ battery and disconnected from the battery. Then it is connected to a $4H$ inductor.

a) Calculate the total energy of the circuit at any time.

Solution:

$$C = 16 \text{ F}; \Delta V = 8 \text{ V}; U_{em} = ?$$

$$Q_{\max} = C\Delta V = 16 \times 8 \text{ C} = 128 \text{ C}$$

$$U_{em} = \frac{Q_{\max}^2}{2C} = \frac{128^2}{2 \times 16} \text{ J} = 512 \text{ J}$$

b) Calculate the current in the circuit when the charge is half of the maximum value

Calculate the maximum value of the current.

Solution:

$$L = 4 \text{ H}; I = ?$$

$$Q = \frac{1}{2} Q_{\max} = \frac{1}{2} (128) \text{ C} = 64 \text{ C}$$

$$U_{em} = \frac{1}{2} LI^2 + \frac{1}{2} \frac{Q^2}{C}$$

I joined MITAS because
I wanted **real responsibility**

The Graduate Programme
for Engineers and Geoscientists
www.discovermitas.com



Month 16

I was a construction
supervisor in
the North Sea
advising and
helping foremen
solve problems

Real work
International opportunities
Three work placements



 **MAERSK**

$$\frac{1}{2}(4)I^2 + \frac{1}{2}\frac{64^2}{16} = 512$$

$$I = 8\sqrt{3} \text{ A}$$

c) Calculate the maximum value of the current.

Solution: The maximum current occurs when the charge is zero.

$$U_{em} = \frac{1}{2}LI_{\max}^2$$

$$\frac{1}{2}(4)I_{\max}^2 = 512 \text{ J}$$

$$I_{\max} = 16 \text{ A}$$

Series RLC Circuit connected to a DC source

Consider a battery of emf ε connected to a series combination of a resistor of resistance R , an inductor of inductance L and a capacitor of capacitance C . Applying Kichhoff's loop rule, results in the equation $\varepsilon - IR - L\frac{dI}{dt} - \frac{1}{C}Q = 0$. Replacing I with $\frac{dQ}{dt}$ (and some rearranging) gives the following second order differential equation for the charge:

$$\frac{d^2Q}{dt^2} + \frac{R}{L}\frac{dQ}{dt} + \frac{1}{LC}Q = \frac{\varepsilon}{L}$$

Let $\frac{R}{L} = 2\beta$ where β is the damping constant. And Let $\frac{1}{LC} = \omega_0^2$ (ω_0 is the angular frequency of an LC circuit and is called the natural angular frequency of the circuit). Then the differential equation becomes

$$\frac{d^2Q}{dt^2} + 2\beta\frac{dQ}{dt} + \omega_0^2Q = \frac{\varepsilon}{L}$$

This is an inhomogenous second order differential equation. Its general solution is the sum of the general solution of the homogeneous equation $\frac{d^2Q}{dt^2} + 2\beta\frac{dQ}{dt} + \omega_0^2Q = 0$ and a particular solution to the inhomogeneous equation (the actual equation). The particular solution (Q_p) can be charge that is independent of time. If Q_p is independent of time, then $\frac{d^2Q_p}{dt^2} = 0$ and $\frac{dQ_p}{dt} = 0$ and it follows that $\omega_0^2Q_p = \frac{\varepsilon}{L}$ or $Q_p = \frac{\varepsilon}{\omega_0^2L}$.

Since $\omega_0 = \frac{1}{LC}$, the particular solution may be written as

$$Q_p = \varepsilon C$$

The homogeneous equation is a second order differential equation with constant coefficients.

There are three types of solutions based on the value of $\beta^2 - \omega_0^2$

1) *Underdamped oscillations*: Under damped oscillation occurs when $\beta^2 - \omega_0^2 < 0$; and the solution to the homogeneous equation, Q_h , is given as

$$Q_h = Ae^{-\beta t} \cos(\omega t - \phi)$$

Where A and ϕ are constants and $\omega = \sqrt{\omega_0^2 - \beta^2}$. Therefore the general solution to the inhomogeneous equation $Q = Q_h + Q_p$ is given by

$$Q = Ae^{-\beta t} \cos(\omega t - \phi) + \varepsilon C$$

This is a damped harmonic oscillation about the value of the charge εC . That is the value of the charge approaches to the value εC as time approaches infinity. The current can be

obtained by taking the derivative of the charge: $I = \frac{dQ}{dt} = -Ae^{-\beta t} [\beta \cos(\omega t - \phi) + \omega \sin(\omega t - \phi)]$.

The cosine and sine can be combined into a single cosine with the transformation equations for β and ω as $\beta = c_1 \cos \delta$ and $\omega = c_1 \sin \delta$ where c_1 and δ are constants: With this transformation equations, the equation for the current reduces to $I = -Ac_1 e^{-\beta t} \cos(\omega t - \phi - \delta)$; and replacing the constants $-Ac_1$ and $\phi + \delta$ by the constants A' and ϕ' , the current is given as

$$I = A'e^{-\beta t} \cos(\omega t - \phi')$$

The current is a damped harmonic oscillation about zero. That is, the current approaches zero as time approaches infinity.

2) *Overdamped Oscillation*: Over damped oscillation occurs when $\beta^2 - \omega_0^2 > 0$; and the

solution to the homogeneous equation, Q_h , is given as $Q_h = c_1 e^{(-\beta + \sqrt{\beta^2 - \omega_0^2})t} + c_2 e^{(-\beta - \sqrt{\beta^2 - \omega_0^2})t}$

Where c_1 and c_2 are arbitrary constants. Therefore the general solution to the inhomogeneous equation ($Q = Q_h + Q_p$) is given as

$$Q = c_1 e^{\left(-\beta + \sqrt{\beta^2 - \omega_0^2}\right)t} + c_2 e^{\left(-\beta - \sqrt{\beta^2 - \omega_0^2}\right)t} + \varepsilon C$$

As time increases, the charge approaches the value εC slowly without oscillation.

3) *Critically damped oscillation:* Critically damped oscillation occurs when $\beta^2 - \omega_0^2 = 0$; and the solution to the homogeneous equation, Q_h is given as $Q_h = (c_1 + c_2 t)e^{-\beta t}$. The general solution to the inhomogeneous equation ($Q = Q_h + Q_p$) is given as

$$Q = (c_1 + c_2 t)e^{-\beta t} + \varepsilon C$$

c_1 and c_2 are arbitrary constants. The charge approaches the value εC as time increases faster than an over damped oscillation does.

Example: A $2\mu\text{F}$ capacitor, a 4mH inductor and a variable resistor are connected to a DC source.

ie business school

#1 EUROPEAN BUSINESS SCHOOL
FINANCIAL TIMES 2013

#gobeyond

MASTER IN MANAGEMENT

Because achieving your dreams is your greatest challenge. IE Business School's Master in Management taught in English, Spanish or bilingually, trains young high performance professionals at the beginning of their career through an innovative and stimulating program that will help them reach their full potential.

- Choose your area of specialization.
- Customize your master through the different options offered.
- Global Immersion Weeks in locations such as London, Silicon Valley or Shanghai.

Because you change, we change with you.

www.ie.edu/master-management | mim.admissions@ie.edu | f t in YouTube

a) Calculate the natural frequency of the circuit.

Solution:

$$C = 2 \times 10^{-6} \text{ F}; L = 4 \times 10^{-3} \text{ H}; f_0 = ?$$

$$\omega_0 = \frac{1}{2\pi\sqrt{LC}} = \frac{1}{2\pi\sqrt{(4 \times 10^{-3})(2 \times 10^{-6})}} \text{ Hz} = 1779 \text{ Hz}$$

b) What should be the value of the resistance be if the oscillation is to be critically damped?

Solution:

$$\beta^2 = \omega_0^2$$

$$\frac{R}{2L} = \sqrt{\frac{1}{LC}}$$

$$R = 2L\sqrt{\frac{1}{LC}} = 2(4 \times 10^{-3})(11180) \Omega = 89.44 \Omega$$

c) Find the range of resistance that will result in a damped harmonic oscillation.

Solution:

$$\beta^2 - \omega_0^2 < 0$$

$$\beta < \omega_0$$

$$\frac{R}{2L} < \omega_0$$

$$R < 2L\omega_0 = 2(4 \times 10^{-3})(11180) \Omega = 89.44 \Omega$$

d) If the resistance is half of the resistance that leads to critical damping, calculate the frequency of the resulting damped harmonic oscillation.

Solution:

$$R = \frac{1}{2}(89.44) \Omega = 44.72 \Omega$$

$$f = \frac{\omega}{2\pi} = \frac{1}{2\pi}\sqrt{\omega_0^2 - \beta^2} = \frac{1}{2\pi}\sqrt{\frac{1}{LC} - \left(\frac{R}{2L}\right)^2} = \frac{1}{2\pi}\sqrt{\frac{1}{(4 \times 10^{-3})(2 \times 10^{-6})} - \left(\frac{44.72}{2(4 \times 10^{-3})}\right)^2} \text{ Hz} = 1541 \text{ Hz}$$

Transformer

A transformer is a device used to increase or decrease the amplitude of an ac voltage (An ac voltage is time varying voltage that varies with time typically like a sine or cosine). It consists of two coils wound on a magnetic material such as iron. One of the coils called the primary coil is connected to an ac source. The second coil which gives the output is called the secondary coil. The current in the primary coil produces magnetic field in the magnetic material uniformly. Thus, this field crosses both coils. Since the current is changing with time (and hence the magnetic field), according to Faraday's law, there will be induced emfs in both coils given by

$$\mathcal{E}_1 = -N_1 \frac{d\phi_1}{dt} \quad \text{and} \quad \mathcal{E}_2 = -N_2 \frac{d\phi_2}{dt}$$

Where N_1 and N_2 are number of turns in the primary and secondary coils respectively; and \mathcal{E}_1 and \mathcal{E}_2 are induced emfs in coil 1 and coil 2 respectively. From Kirchhoff's rule \mathcal{E}_1 is equal to the input voltage in the primary. ϕ_1 and ϕ_2 are fluxes crossing coil 1 and coil 2 respectively.

But since both coils are crossed by the same magnetic field and the cross-sectional area of the magnetic material is the same for both, ϕ_1 and ϕ_2 are equal ($\phi_1 = \phi_2 = BA$). Hence the $\mathcal{E}mf$'s may be written as $\frac{\mathcal{E}_1}{N_1} = -\frac{d\phi_1}{dt}$ and $\frac{\mathcal{E}_2}{N_2} = -\frac{d\phi_1}{dt}$ which implies $\frac{\mathcal{E}_1}{N_1} = \frac{\mathcal{E}_2}{N_2}$ or

$$\mathcal{E}_2 = \frac{N_2}{N_1} \mathcal{E}_1$$

This implies that the output voltage can be adjusted to a desired voltage by the coil of a suitable $\frac{N_2}{N_1}$ ratio. A transformer whose effect is to increase voltage with $N_2 > N_1$ is called a step up transformer; and a transformer whose effect is to decrease voltage with $N_2 < N_1$ is called a step down transformer.

Example: The primary coil and the secondary coil of a transformer have 50 and 125 turns respectively. The primary coil is connected to an ac voltage of amplitude 10 V.

a) Calculate the amplitude of the voltage obtained from the secondary coil.

Solution:

$$N_1 = 50; N_2 = 125; \varepsilon_1 = 10 \text{ V}; \varepsilon_2 = ?$$

$$\varepsilon_2 = \frac{N_2}{N_1} \varepsilon_1 = \frac{125}{50} (10) \text{ V} = 25 \text{ V}$$

b) Is this a step up or step down transformer?

Solution: Since its effect is to increase the amplitude of the voltage, it is a step up transformer.



"I studied English for 16 years but...
...I finally learned to speak it in just six lessons"
Jane, Chinese architect

ENGLISH OUT THERE

Click to hear me talking before and after my unique course download

Practice Quiz 10.2*Choose the best answer*

- Which of the following statements is a correct statement?
 - When a charged capacitor is connected to an inductor, the sum of the electrical energy stored in the capacitor and the magnetic energy stored in the inductor is independent of time.
 - When a charged capacitor is connected to an inductor, the charge in the capacitor decreases exponentially as function of time
 - When a series combination of a resistor, an inductor and a capacitor is connected to a DC source, damped harmonic oscillation occurs when the damping constant is greater than the natural frequency of the circuit.
 - A step-up transformer is a transformer where the number of coils of the primary is greater than the number of coils of the secondary coil.
 - The mutual inductance of coil A and coil B is defined to be the average of the self-inductances of coil A and coil B.

- Consider two concentric solenoids of radii 0.051 m and 0.086 m. The number of coils for the inner and outer solenoids are 575 and 875 respectively. Both solenoids have a length of 0.16 m. Calculate the mutual inductance of the coils.
 - $59.142e-3$ H
 - $44.84e-3$ H
 - $26.261e-3$ H
 - $14.313e-3$ H
 - $32.289e-3$ H

- Two concentric solenoids have a mutual inductance of $3.5e-3$ H. The inner and outer solenoids carry currents that vary with time according to the equation $I(t) = 1.3 \sin(374t)$ A and $I(t) = 0.18 \sin(374t)$ A respectively. Calculate the voltage induced by the inner coil on the outer coil after $1.5e-3$ seconds.
 - $-1197.688e-3$ V
 - $-319.229e-3$ V
 - $-1440.869e-3$ V
 - $-844.75e-3$ V
 - $-1729.043e-3$ V

4. A $3.5e-6$ F capacitor is connected to a 2.5 V battery. Then it is disconnected from the battery and connected to a $4.1e-3$ H inductor. How long does the current take to make one complete oscillation?
- A. $0.37e-3$ s
 - B. $1.28e-3$ s
 - C. $1.362e-3$ s
 - D. $0.753e-3$ s
 - E. $0.524e-3$ s
5. A 3.5 F capacitor is connected to a 5.3 V battery. Then it is disconnected from the battery and connected to a $7.3e-3$ H inductor. Calculate the charge in the capacitor after 0.55 seconds.
- A. -31.659 C
 - B. -12.731 C
 - C. -6.157 C
 - D. -17.725 C
 - E. -10.722 C
6. A 3.5 F capacitor is connected to a 7.5 V battery. Then it is disconnected from the battery and connected to a $4.1e-3$ H inductor. Calculate the magnetic energy stored in the inductor after 0.6 seconds.
- A. $150721.951e-3$ J
 - B. $41418.087e-3$ J
 - C. $74910.727e-3$ J
 - D. $162280.333e-3$ J
 - E. $90044.493e-3$ J
7. A 4 F capacitor is connected to a 10 V battery. Then it is disconnected from the battery and connected to a 20 H inductor. Calculate the charge stored by the capacitor when the current in the circuit is 3 A.
- A. 29.665 C
 - B. 7.816 C
 - C. 44.356 C
 - D. 52.64 C
 - E. 48.418 C

8. A series combination of a $55\ \Omega$ resistor, a $20\ \text{H}$ inductor and a $8\ \text{F}$ capacitor is connected to a $3\ \text{V}$ battery. Calculate the damping constant of the circuit.
- A. $1.029\ \Omega/\text{H}$
 - B. $1.56\ \Omega/\text{H}$
 - C. $1.375\ \Omega/\text{H}$
 - D. $1.725\ \Omega/\text{H}$
 - E. $1.911\ \Omega/\text{H}$
9. A series combination of a $1000\ \Omega$ resistor, a $2\ \text{H}$ inductor and a $8e-6\ \text{F}$ capacitor is connected to a $5\ \text{V}$ battery. The variation of the current as a function of time will be
- A. under damped
 - B. critically damped
 - C. over damped
 - D. simple harmonic
 - E. a parabola

Excellent Economics and Business programmes at:



university of
 groningen



“The perfect start
of a successful,
international career.”

CLICK HERE
to discover why both socially
and academically the University
of Groningen is one of the best
places for a student to be

www.rug.nl/feb/education

10. A series combination of an unknown resistor, a 3 H inductor and a $4e-6\text{ F}$ capacitor is connected to a 6 V battery. If the variation of the current is under damped and the period of the oscillation is 0.8 seconds, calculate the resistance of the unknown resistor.
- A. $2033.534\ \Omega$
 - B. $1731.41\ \Omega$
 - C. $2740.393\ \Omega$
 - D. $958.766\ \Omega$
 - E. $1263.392\ \Omega$
11. The number of turns of the primary and the secondary coils of a transformer are 825 and 975 respectively. If the input ac voltage has an amplitude of 35 V , calculate the amplitude of the output voltage.
- A. 33.877 V
 - B. 28.576 V
 - C. 41.364 V
 - D. 61.923 V
 - E. 50.162 V

11 ALTERNATING CURRENT CIRCUITS

Your goal for this chapter is to learn about the properties of alternating current circuits.

Your goals for this chapter are to learn about alternating current circuits involving a resistor, an inductor and a capacitor.

An alternating current circuit (ac) is a circuit where the voltage and the current vary with time typically like a sine or a cosine. A typical ac signal may be given as $v = V \sin(\omega t + \beta)$. v is the voltage at a given instant of time and is called instantaneous voltage. V is the maximum value of the voltage and is called the amplitude of the voltage. ω is the number of radians executed per second and is called the angular frequency of the voltage. It is related with frequency (f) as $\omega = 2\pi f$ and with period (T) as $\omega = 2\pi/T$. β is called the phase angle of the voltage. Its effect is to shift the graph of $\sin(\omega t)$ either to the right (if negative) or to the left (if positive).

Phase angle of signal 2 minus the phase angle of signal 1 is called the *phase shift* (θ) of signal 2 with respect to signal 1. The one with a bigger phase angle is said to be leading the other and the one with a smaller phase angle is said to be lagging from the other. If $v_1 = V_1 \sin(\omega t + \beta_1)$ and $v_2 = V_2 \sin(\omega t + \beta_2)$, then

$$\theta = \beta_2 - \beta_1$$

Example: An ac voltage varies with time according to the equation $v = 120 \text{ V} \sin(300t + \pi/2)$

- a) What is the maximum value of the voltage?

Solution: $V = ?$

$$V = 120 \text{ V}$$

- b) How long does it take to make one complete oscillation?

Solution: $\omega = 300 \text{ rad/s}$; $T = ?$

$$T = 2\pi/\omega = 2 * 3.14 / 300 \text{ s} = 0.021 \text{ s}$$

c) What is its phase angle?

Solution: $\beta = ?$

$$\beta = \pi/2$$

Example: Calculate the phase shift between the following pair of signals and indicate which one is leading: $v_1 = 10 \text{ V sin } (20t + \pi)$ and $v_2 = 20 \text{ V sin } (20t - \pi/2)$

Solution: $\beta_1 = \pi$; $\beta_2 = -\pi/2$; $\theta = ?$

$$\theta = \beta_2 - \beta_1 = -\pi/2 - \pi = -3\pi/2$$

v_1 is leading because its phase angle is bigger.



American online
LIGS University
is currently enrolling in the
Interactive Online **BBA, MBA, MSc,**
DBA and PhD programs:

- ▶ enroll **by September 30th, 2014** and
- ▶ **save up to 16%** on the tuition!
- ▶ pay in 10 installments / 2 years
- ▶ Interactive **Online education**
- ▶ visit www.ligsuniversity.com to find out more!

Note: LIGS University is not accredited by any nationally recognized accrediting agency listed by the US Secretary of Education. More info [here](#).

A Resistor Connected to an ac Source

Let's consider a resistor of resistance R connected to an ac source whose voltage varies with time according to the equation $v = V \sin(\omega t)$. Ohm's law applies to ac circuits instantaneously. Therefore the equation $v = iR$ holds where i stands for the instantaneous current. This implies that

$$i = (V/R) \sin(\omega t) \text{ when } v = V \sin(\omega t)$$

This shows that, in a resistor, the phase shift (θ_R) between the voltage and the current is zero. In other words, the voltage and the current are in phase.

$$\theta_R = 0$$

Where $\theta_R = \beta_v - \beta_i$ is the phase shift of voltage with respect to current for a resistor. Since $i = I \sin(\omega t) = (V/R) \sin(\omega t)$, Ohm's law also applies to the amplitudes of the voltage and the current.

$$V = IR$$

Example: A resistor of resistance 50 ohm is connected to an ac source whose potential difference varies with time according to the equation $v = 20 \text{ V} \sin(100t)$.

- a) Calculate the amplitude of the current.

Solution: $V = 20 \text{ V}; R = 50; I = ?$

$$I = V/R = 20/50 \text{ A} = 0.4 \text{ A}$$

- b) Give a formula for the instantaneous current as a function of time.

Solution: $\omega = 100 \text{ rad/s}; i(t) = ?$

$$i(t) = I \sin(\omega t) = 0.4 \text{ A} \sin(100t)$$

c) Calculate the instantaneous voltage and current after 10 s.

Solution: $t = 10$ s; $i = ?$; $v = ?$

$$i = I \sin(\omega t) = 0.4 * \sin(100 * 10) \text{ A} = 0.33 \text{ A}$$

$$v = V \sin(\omega t) = 20 * \sin(100 * 10) \text{ V} = 16.5 \text{ V}$$

A Capacitor Connected to an ac Source

Let's consider a capacitor of capacitance C connected to an ac source whose potential difference varies with time according to the equation $v = V \sin(\omega t)$. The instantaneous charge q of the capacitor is related with the instantaneous voltage by $q = vC$. The instantaneous current is equal to the rate of change of the charge or the derivative of charge with respect to time in the language of calculus. Therefore, using calculus (because it can't be done algebraically), $i = dq/dt = C dv/dt = C d\{V \sin(\omega t)\}/dt = CV\omega \cos(\omega t)$. But $\cos(\omega t) = \sin(\omega t + \pi/2)$

$$i = CV\omega \sin(\omega t + \pi/2) \text{ when } v = V \sin(\omega t)$$

This implies that for a capacitor, the voltage lags from the current by $\pi/2$ or 90° .

$$\theta_c = \beta_v - \beta_i = -\pi/2$$

Where θ_c is the phase shift of the voltage with respect to current for a capacitor. Since $i = I \sin(\omega t + \pi/2) = CV\omega \sin(\omega t + \pi/2)$,

$$I = CV\omega$$

Where I is the amplitude of the current. The ratio between the amplitude of the voltage across a capacitor and the amplitude of the current across a capacitor is defined to be the **capacitive reactance** (X_c) of the capacitor.

$$X_c = V/I$$

The unit of measurement for capacitive reactance is ohm. Replacing I by $VC\omega$, it follows that the capacitive reactance of a capacitor is inversely proportional to the frequency of the voltage (current).

$$X_c = 1/(\omega C)$$

Example: A capacitor of capacitance $20 \mu\text{F}$ is connected to an ac source whose potential difference varies with time according to the equation $v = 12 \text{ V } \sin(500t)$.

a) Calculate its capacitive reactance.

Solution: $C = 20 \mu\text{F} = 2e-5 \text{ F}$; $\omega = 500 \text{ rad/s}$; $X_C = ?$

$$X_C = 1/(\omega C) = 1/(500 * 2e-5) \Omega = 100 \Omega$$

b) Calculate the amplitude of the current.

Solution: $V = 12 \text{ V}$; $I = ?$

$$I = V/X_C = 12/100 \text{ A} = 0.12 \text{ A}$$

.....Alcatel-Lucent 

www.alcatel-lucent.com/careers

What if you could build your future and create the future?

One generation's transformation is the next's status quo. In the near future, people may soon think it's strange that devices ever had to be "plugged in." To obtain that status, there needs to be "The Shift".

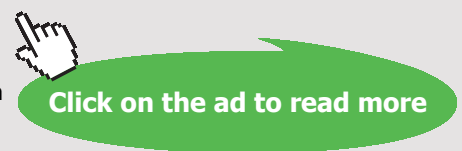

c) Give a formula for the current as a function of time.

Solution: For a capacitor, the current leads the voltage by $\pi/2$. Therefore, since the phase angle of the voltage is zero, the phase angle of the current must be $\pi/2$.

$$\theta_C = -\pi/2; i(t) = ?$$

$$i = I \sin(\omega t - \theta_C) = 0.12 \text{ A} \sin(500t + \pi/2)$$

An Inductor Connected to an ac Source

Let's consider an inductor of inductance L connected to an ac source where the current in the circuit varies with time according to the equation $i = I \sin(\omega t)$. From Kirchoff's loop rule, the voltage of the source is the negative of the self-induced voltage (so that they add up to zero): $v = -E_{\text{self}}$. But $E_{\text{self}} = -L di/dt$ (using calculus). Hence $v = L di/dt = L d\{I \sin(\omega t)\}/dt = L\omega I \cos(\omega t)$. And $\cos(\omega t) = \sin(\omega t + \pi/2)$.

$$v = L\omega I \sin(\omega t + \pi/2) \text{ when } i = I \sin(\omega t)$$

This means, for an inductor, the voltage leads the current by $\pi/2$ or 90° .

$$\theta_L = \pi/2$$

Where $\theta_L = \beta_v - \beta_i$ is the phase shift of the voltage with respect to the current. Since $v = V \sin(\omega t + \pi/2) = L\omega I \sin(\omega t + \pi/2)$,

$$V = L\omega I$$

The ratio between the amplitude of the voltage across an inductor and the current across the inductor is called the *inductive reactance* (X_L) of the inductor.

$$X_L = V/I$$

The unit of measurement for inductive reactance is the ohm. Replacing V by $L\omega I$, it is seen that the inductive reactance of an inductor is directly proportional to the frequency of the signal.

$$X_L = \omega L$$

Example: An inductor of inductance 15 mH is connected to an ac source whose potential difference varies with time according to the equation $v = 40 \text{ V } \sin (250t)$.

- a) Calculate its inductive reactance.

Solution: $\omega = 250 \text{ rad/s}$; $L = 15 \text{ mH} = 0.015 \text{ H}$; $X_L = ?$

$$X_L = \omega L = 250 * 0.015 \Omega = 3.75 \Omega$$

- b) Calculate the amplitude of the current.

Solution: $I = ?$

$$I = V/X_L = 40/3.75 \text{ A} = 10.7 \text{ A}$$

- c) Give a formula for the current as a function of time.

Solution: For an inductor, the current lags from the voltage by $\pi/2$ and the phase angle of the voltage is zero. The phase angle of the current must be $-\pi/2$.

$$\theta_L = \pi/2; i(t) = ?$$

$$i(t) = I \sin (\omega t - \theta_L) = 10.7 \text{ A } \sin (250t - \pi/2)$$

Practice Quiz 11.1

Choose the best answer

1. A certain signal varies with time according the equation $x = 6 * \sin (45t + 1.5)$. The angular frequency of the signal is.
A. 3.14
B. 6
C. 6.28
D. 45
E. 1.5

2. Which of the following is a correct statement?
- A. For a resistor connected to an ac signal, the voltage leads the current by 90° .
 - B. For a capacitor connected to an ac signal, the current leads the voltage by 90° .
 - C. The capacitive reactance of a capacitor is proportional to the frequency of the ac signal to which it is connected to
 - D. The inductive reactance of an inductor is inversely proportional to the frequency of the ac signal to which it is connected to.
 - E. For an inductor connected to an ac signal, the current leads the voltage by 90° .
3. A certain signal varies with time according the equation $x = 4 * \sin(30t + 0.25)$. How long does it take to make one complete cycle?
- A. 0.147 s
 - B. 0.209 s
 - C. 0.126 s
 - D. 0.251 s
 - E. 0.188 s



In the past four years we have drilled

81,000 km

That's more than **twice** around the world.

Who are we?
We are the world's leading oilfield services company. Working globally—often in remote and challenging locations—we invent, design, engineer, manufacture, apply, and maintain technology to help customers find and produce oil and gas safely.

Who are we looking for?
We offer countless opportunities in the following domains:

- **Engineering, Research, and Operations**
- **Geoscience and Petrotechnical**
- **Commercial and Business**

If you are a self-motivated graduate looking for a dynamic career, apply to join our team.

What will you be?

Schlumberger

careers.slb.com

4. Identify the pair of signal for which x is leading y .
- A. $x = 20 \sin (40t - 2)$
 $y = \sin (40t)$
- B. $x = 20 \sin (40t - 1)$
 $y = \sin (40t - 3)$
- C. $x = 20 \sin (40t - 1)$
 $y = \sin (40t + 1)$
- D. $x = 20 \sin (40t + 1)$
 $y = \sin (40t + 3)$
- E. $x = 20 \sin (40t)$
 $y = \sin (40t + 3)$
5. When a resistor of resistance 15.3 Ohm is connected to a sinusoidal ac voltage, a current that varies with time according the equation $i = 0.95 \text{ A} * \sin (300t)$ flows in the circuit. Calculate the amplitude of the voltage across the resistor.
- A. 8.721 V
 B. 14.535 V
 C. 10.175 V
 D. 13.082 V
 E. 17.442 V
6. A resistor of resistance 44.7 Ohm is connected to an ac voltage that varies with time according to the equation $71 \text{ V} * \sin (100t)$. Give a formula for the instantaneous current as a function of time.
- A. $1.588 \text{ A} * \sin (100t - 1.57)$
 B. $1.43 \text{ A} * \sin (100t + 1.57)$
 C. $1.588 \text{ A} * \sin (100t)$
 D. $1.43 \text{ A} * \sin (100t)$
 E. $1.588 \text{ A} * \sin (100t + 1.57)$
7. An inductor has an inductive reactance of 620 Ohm when connected to an ac voltage of frequency 170 Hz . Calculate the inductance of the inductor.
- A. 0.58 H
 B. 0.464 H
 C. 0.406 H
 D. 0.638 H
 E. 0.813 H

8. When an inductor of inductance 0.035 H is connected to a sinusoidal ac voltage, a current that varies with time according the equation $i = 2.5 \text{ A} * \sin (45t)$. Give a formula for the instantaneous voltage as a function of time.
- A. $3.938 \text{ V} * \sin (45t + 1.57)$
 - B. $3.938 \text{ V} * \sin (45t)$
 - C. $3.544 \text{ V} * \sin (45t)$
 - D. $3.938 \text{ V} * \sin (45t - 1.57)$
 - E. $3.544 \text{ V} * \sin (45t + 1.57)$
9. A capacitor has an capacitive reactance of 83 Ohm when connected to an ac voltage of frequency 140 Hz. Calculate its capacitive reactance when connected to an ac voltage of frequency 90 Hz.
- A. 129.111 Ohm
 - B. 116.2 Ohm
 - C. 154.933 Ohm
 - D. 180.756 Ohm
 - E. 90.378 Ohm
10. A capacitor of capacitance 0.053 F is connected to an ac voltage that varies with time according the equation $v = 4.0 \text{ V} * \sin (12.5t)$. Calculate the amplitude of the current through the capacitor.
- A. 1.855 A
 - B. 3.71 A
 - C. 2.915 A
 - D. 3.18 A
 - E. 2.65 A

Series Combination of a Resistor, an Inductor and a Capacitor Connected to an ac Source

Let's consider a series combination of a resistor of resistance R , an inductor of inductance L and a capacitor of capacitance C connected to an ac source where the current in the circuit varies with time according the equation $i = I \sin (\omega t)$. The currents through the resistor (i_R), the inductor (i_L) and the capacitor (i_C) are equal and they are equal to the current in the circuit.

$$i_R = i_L = i_C = i = I \sin (\omega t)$$

The net instantaneous potential difference (v) is equal to the sum of the instantaneous potential differences across the resistor (v_R), the inductor (v_L) and capacitor (v_C).

$$v = v_R + v_L + v_C$$

In a resistor, the voltage and the current are in phase; that is, their phase angles are equal. Therefore, since $i = I \sin(\omega t)$, the instantaneous potential difference across the resistor is given by

$$v_R = V_R \sin(\omega t)$$

Where $V_R = IR$. In an inductor, the voltage leads the current by $\pi/2$; that is, the phase angle of the voltage is $\pi/2$ more than the phase angle of the current. Since the current is given as $i = I \sin(\omega t)$, the instantaneous potential difference across the inductor is given by

$$v_L = V_L \sin(\omega t + \pi/2)$$

Where $V_L = IX_L$. In a capacitor, the potential difference lags from the current by $\pi/2$; that is the phase angle of the voltage is $\pi/2$ less than the phase angle of the current. Since the current is given as $i = I \sin(\omega t)$, the instantaneous voltage across the capacitor is given by

$$v_C = V_C \sin(\omega t - \pi/2)$$



Maastricht University

*Leading
in Learning!*

**Join the best at
the Maastricht University
School of Business and
Economics!**

Top master's programmes

- 33rd place Financial Times worldwide ranking: MSc International Business
- 1st place: MSc International Business
- 1st place: MSc Financial Economics
- 2nd place: MSc Management of Learning
- 2nd place: MSc Economics
- 2nd place: MSc Econometrics and Operations Research
- 2nd place: MSc Global Supply Chain Management and Change

Sources: Keuzegids Master ranking 2013; Elsevier 'Beste Studies' ranking 2012; Financial Times Global Masters in Management ranking 2012

**Maastricht
University is
the best specialist
university in the
Netherlands
(Elsevier)**

**Visit us and find out why we are the best!
Master's Open Day: 22 February 2014**

www.mastersopenday.nl

Where $V_C = IX_C$. The net instantaneous voltage is the sum of the instantaneous voltages across the resistor, inductor and capacitor: $v = V_R \sin(\omega t) + V_L \sin(\omega t + \pi/2) + V_C \sin(\omega t - \pi/2)$. But $\sin(\omega t + \pi/2) = \cos(\omega t)$ and $\sin(\omega t - \pi/2) = -\cos(\omega t)$. Therefore, $v = V_R \sin(\omega t) + (V_L - V_C) \cos(\omega t)$. Also, if the phase shift of the net voltage with respect to the current is θ , then

$$v = V \sin(\omega t + \theta)$$

This expression of v can be expressed in terms of $\cos(\omega t)$ and $\sin(\omega t)$ by expanding the sine: $v = V \cos(\theta) \sin(\omega t) + V \sin(\theta) \cos(\omega t)$. The coefficients of $\cos(\omega t)$ and $\sin(\omega t)$ of both expressions of v can be equated because $\cos(\omega t)$ and $\sin(\omega t)$ are independent functions.

$$V_R = V \cos(\theta) \dots (1)$$

$$V_L - V_C = V \sin(\theta) \dots (2)$$

An expression for the phase shift of the voltage with respect to the current can be obtained by dividing equation (2) by equation (1): $\sin(\theta) / \cos(\theta) = \tan(\theta) = (V_L - V_C) / V_C = (IX_L - IX_C) / (IR) = (X_L - X_C) / R$. Thus θ is given as follows:

$$\theta = \arctan \{ (X_L - X_C) / R \} = \{ [\omega L - 1/(\omega C)] / R \}$$

An expression for the amplitude of the net voltage can be obtained by squaring equations (1) and (2) and adding: $V_R^2 + (V_L - V_C)^2 = \{ V \cos(\theta) \}^2 + \{ V \sin(\theta) \}^2 = V^2$. Therefore, the amplitude of the net voltage is related with the amplitudes of the voltages across the resistor, inductor and capacitor as follows:

$$V = \sqrt{\{ V_R^2 + (V_L - V_C)^2 \}}$$

The total **impedance** (Z) of the series combination is defined to be the ratio between the between the amplitude of the net voltage and the amplitude of the current in the circuit.

$$Z = V/I$$

An expression for Z in terms of R , L , C can be obtained by expressing the voltages in terms of the current: $Z = V/I = \sqrt{\{(IR)^2 + (IX_L - IX_C)^2\}} / I$. Hence,

$$Z = \sqrt{\{ R^2 + (X_L - X_C)^2 \}} = \sqrt{\{ R^2 + [\omega L - 1/(\omega C)]^2 \}}$$

Example: A $200\ \Omega$ resistor, a $20\ \text{H}$ inductor and a $5\ \text{mF}$ capacitor are connected in series and then connected to an ac source whose potential difference varies with time according to the equation $v = 120\ \text{V} \sin(15t)$.

a) Calculate the impedance of the circuit.

Solution: $R = 200\ \Omega$; $L = 20\ \text{H}$; $C = 5\ \text{mF} = 5 \times 10^{-3}\ \text{F}$; $\omega = 15\ \text{rad/s}$; $Z = ?$

$$Z = \sqrt{R^2 + [\omega L - 1/(\omega C)]^2} = \sqrt{200^2 + (15 * 20 - 1/15/5 \times 10^{-3})^2} \Omega = 349.5\ \Omega$$

b) Calculate the amplitude of the current.

Solution: $V = 120\ \text{V}$; $I = ?$

$$I = V/Z = 120/349.5\ \text{A} = 0.343\ \text{A}$$

c) Calculate the amplitudes of the voltages across the resistor, inductor and capacitor.

Solution: $V_R = ?$; $V_L = ?$; $V_C = ?$

$$V_R = IR = 0.343 * 200\ \text{V} = 68.6\ \text{V}$$

$$V_L = IX_L = I\omega L = 0.343 * 15 * 20\ \text{V} = 102.9\ \text{V}$$

$$V_C = IX_C = I/(\omega C) = 0.343 / (15 * 5 \times 10^{-3})\ \text{V} = 4.6\ \text{V}$$

d) Calculate the phase shift of the voltage with respect to the current. Which one is leading?

Solution: $\theta = ?$

$$\theta = \arctan \{ [\omega L - 1/(\omega C)]/R \} = \arctan \{ [15 * 20 - 1/(15 * 5 \times 10^{-3})] / 200 \}$$
$$\text{deg} = 55^\circ$$

Or

$$\cos(\theta) = V_R/V$$

$$\theta = \arccos(V_R/V) = \arccos(68.6/120)\ \text{deg} = 55^\circ$$

Since the phase shift of voltage with respect to current ($\theta = \beta_v - \beta_i$) is positive, the voltage is leading.

e) Obtain a formula for the current as a function of time.

Solution: Since the voltage leads the current by θ and the phase angle of the voltage is zero, the phase angle of the current should be $-\theta$

$$\theta = 55^\circ = 55 \cdot 3.14 / 180 \text{ rad} = 0.96 \text{ rad}; \beta_i = 0 \text{ (because } v = V \sin(\omega t)); i(t) = ?$$

$$\theta = \beta_v - \beta_i$$

$$\beta_i = \beta_v - \theta = 0 - 0.96 = -0.96$$

$$i(t) = I \sin(\omega t + \beta_i) = 0.343 \text{ A} \sin(15t - 0.96)$$



> Apply now

**REDEFINE YOUR FUTURE
 AXA GLOBAL GRADUATE
 PROGRAM 2015**

redefining / standards 

agence.cdg - © Photonistop



- f) Obtain formulas for the voltages across the resistor, inductor and capacitor as a function of time.

Solution: $\theta_R = 0$; $\theta_L = \pi/2$; $\theta_C = -\pi/2$; $v_R(t) = ?$; $v_L(t) = ?$; $v_C(t) = ?$

$$\theta_R = \beta_{Rv} - \beta_i$$

$$\beta_{Rv} = \theta_R + \beta_i = 0 + -0.96 = -0.96$$

$$v_R = V_R \sin(\omega t + \beta_{Rv}) = 68.6 \text{ V} \sin(15t - 0.96) \quad \theta_L = \beta_{Lv} - \beta_i$$

$$\beta_{Lv} = \theta_L + \beta_i = \pi/2 + -0.96 = \pi/2 - 0.96$$

$$v_L = V_L \sin(\omega t + \beta_{Lv}) = 102.9 \text{ V} \sin(15t + \pi/2 - 0.96) \quad \theta_C = \beta_{Cv} - \beta_i$$

$$\beta_{Cv} = \theta_C + \beta_i = -\pi/2 + -0.96 = -\pi/2 - 0.96$$

$$v_C = V_C \sin(\omega t + \beta_{Cv}) = 4.6 \text{ V} \sin(15t - \pi/2 - 0.96)$$

Resonant Frequency

The Amplitude of the current through a series connection of a resistor, an inductor and capacitor depends on the frequency of the source, because the impedance of the combination depends on frequency. The frequency for which the amplitude of the current is the maximum for a given amplitude of the voltage is called *resonant frequency* of the circuit. Since $I = V/Z$, I is maximum when Z is minimum. Since $Z = \sqrt{\{R^2 + [\omega L - 1/(\omega C)]^2\}}$, Z is minimum when $\omega L - 1/(\omega C) = 0$. Therefore the resonant angular frequency (ω_o) is the frequency that makes this expression zero.

$$\omega_o = 1/\sqrt{LC}$$

The resonant frequency is obtained by dividing the resonant angular frequency by 2π ; that is, $f_o = 1/\{2\pi \sqrt{LC}\}$. Resonant frequency has a very important application in the tuning circuits of radios, televisions and others. A tuning circuit may have a variable capacitor. The capacitance of the variable capacitor can be dialed so that the resonant frequency of the tuning circuit is equal to the frequency of the signal to be picked. When signals with different frequencies arrive on the device, only the signal whose frequency is equal to the resonant frequency will be received with a significant current.

Example: The tuning circuit of a radio consists of a series combination of a $1000\ \Omega$ resistor, $0.004\ \text{H}$ and a variable capacitor. To what capacitance should the capacitor be dialed, if the radio is to pick a signal whose frequency is $2e6\ \text{Hz}$.

Solution: The capacitance of the capacitor should be dialed to a value that makes the resonant frequency of the tuning circuit equal to the frequency of the signal to be picked.

$$f_o = 2e6\ \text{Hz}; L = 0.004\ \text{H}; C = ?$$

$$f_o = 1 / \{ 2\pi \sqrt{LC} \}$$

$$f_o^2 = 1 / (4\pi^2 LC)$$

$$C = 1 / (4\pi^2 f_o^2 L) = 1 / (4 * 3.14^2 * 2e6^2 * 0.004)\ \text{F} = 1.6e-12\ \text{F}$$

Root Mean Square Value

The *root mean square (RMS) value* of an ac signal is defined to be the square root of the average of the square of the signal. Let's consider an ac voltage that varies with time according to the equation $v = V \sin(\omega t)$. Squaring $v^2 = V^2 \sin^2(\omega t)$. The square of the sine can be expanded using the double angle formula: $v^2 = V^2/2 - V^2 \cos(2\omega t)/2$. The average of the first term is itself $V^2/2$ because it is a constant. The average of the second term is zero because cosine alternates between equal (numerically) positives and negatives periodically. Therefore the RMS value (V_{RMS}) of an ac signal is equal to the square root of $V^2/2$; that is, the RMS value of an ac signal is obtained by dividing the amplitude by $\sqrt{2}$.

$$V_{RMS} = V / \sqrt{2}$$

Similarly the RMS value of the current is given as $I_{RMS} = I / \sqrt{2}$. ac voltmeters and ammeters are designed to measure RMS values.

Example: An ac voltmeter connected to an ac voltage reads $10\ \text{V}$. What is the amplitude of the voltage.

Solution: The reading of the voltmeter is equal to the RMS value of the voltage.

$$V_{RMS} = 10\ \text{V}; V = ?$$

$$V = \sqrt{2} V_{RMS} = \sqrt{2} * 10\ \text{V} = 14.1\ \text{V}$$

Average Power

The instantaneous power dissipated in ac circuits is given as the product of the instantaneous voltage and instantaneous current. Suppose the current varies with time in the form $i = I \sin(\omega t)$ and the phase shift of the voltage with respect to the current is θ . Then, the voltage is given as $v = V \sin(\omega t + \theta)$ and the instantaneous power varies with time as $VI \sin(\omega t) \sin(\omega t + \theta) = VI \cos(\theta) \sin^2(\omega t) + VI \sin(\theta) \sin(\omega t) \cos(\omega t)$ (the last expression is obtained by expanding $\sin(\omega t + \theta)$). The average of the first term is $VI \cos(\theta)/2$ because the average of $\sin^2(\omega t)$ is equal to $1/2$ as obtained in the previous section. The average of the second term is zero because $\sin(\omega t) \cos(\omega t) = \sin(2\omega t)/2$ whose average is zero because sine alternates between equal (numerically) positives and negatives periodically. Therefore, the average power (P_{av}) of an ac circuit is given as follows:

$$P_{av} = IV \cos(\theta)/2 = I_{RMS} V_{RMS} \cos(\theta)$$



The image shows a central logo for BI Norwegian Business School, consisting of a blue square with the letters 'BI' in white. Surrounding this central logo are numerous colorful, 3D-style rectangular bars of various colors (red, orange, yellow, green, blue, purple) radiating outwards. Each bar has a label for a business program: 'Business', 'Strategic Marketing Management', 'International Business', 'Leadership & Organisational Psychology', 'Shipping Management', and 'Financial Economics'.

Empowering People. Improving Business.

BI Norwegian Business School is one of Europe's largest business schools welcoming more than 20,000 students. Our programmes provide a stimulating and multi-cultural learning environment with an international outlook ultimately providing students with professional skills to meet the increasing needs of businesses.

BI offers four different two-year, full-time Master of Science (MSc) programmes that are taught entirely in English and have been designed to provide professional skills to meet the increasing need of businesses. The MSc programmes provide a stimulating and multi-cultural learning environment to give you the best platform to launch into your career.

- MSc in Business
- MSc in Financial Economics
- MSc in Strategic Marketing Management
- MSc in Leadership and Organisational Psychology

BI NORWEGIAN BUSINESS SCHOOL

EFMD
EQUIS
ACCREDITED

www.bi.edu/master

The value $\cos(\theta)$ is called the power factor of the circuit. The circuit yields no power if the phase shift of voltage with respect to current is $\pm \pi/2$ (because $\cos(\pi/2) = 0$). For example, no power can be extracted from an inductor or a capacitor because their phase shifts are $\pi/2$ and $-\pi/2$ respectively. Only a resistor yields power because for a resistor the phase shift is zero and $\cos(0) = 1$. Actually, it can be said that the power dissipated in a series connection of a resistor, inductor and capacitor, the power dissipated in the circuit is equal to the power dissipated in the resistor. Since $\cos(\theta) = V_R/V = IR/V$, the average power can also be written as

$$P_{av} = I^2 R / 2 = I_{RMS}^2 R$$

Example: A 500Ω resistor, a 60 H inductor and a 0.006 F capacitor are connected in series and then connected to a potential difference that varies with time according to the equation $v = 20 \text{ V} \sin(20t)$.

- a) Calculate the average power dissipated in the circuit.

Solution: $V = 20 \text{ V}$; $\omega = 20 \text{ rad/s}$; $R = 500 \Omega$ $L = 60 \text{ H}$; $C = 0.006 \text{ F}$; $I = ?$ ($P_{av} = I^2 R / 2$); $P_{av} = ?$

$$I = V/Z = V/\sqrt{\{R^2 + [\omega L - 1/(\omega C)]^2\}} = 20/\sqrt{\{500^2 + [20 * 60 - 1/(20 * 0.006)]^2\}} \text{ A} = 0.015 \text{ A}$$

$$P_{av} = I^2 R / 2 = 0.015^2 * 500 / 2 \text{ W} = 0.06 \text{ W}$$

- b) Calculate the average power dissipated across the resistor, inductor and capacitor.

Solution The power dissipated across the resistor is equal to the power dissipated in the circuit which is 0.06 W . The power dissipated across the inductor is zero because the phase shift of voltage with respect to current is $\pi/2$. The average power dissipated across the capacitor is zero because the phase shift of the voltage with respect to current is $-\pi/2$.

Practice Quiz 11.2

Choose the best answer

- Which of the following is a correct statement?
 - The RMS value of an ac signal is the average of the signal.
 - The power factor of an RLC series ac circuit is equal to the sine of the phase shift between the voltage and the current.
 - The resonant frequency of the series connection of a resistor, inductor and capacitor connected to an ac signal is the frequency of the signal for which the amplitude of the voltage is maximum.
 - Power cannot be delivered by a capacitor
 - Power can be delivered by an inductor.
- The maximum possible power is dissipated in an RLC series circuit when the phase shift between the voltage and the current is
 - 30°
 - 0°
 - 60°
 - 45°
 - 90°
- Calculate the amplitude of an ac voltage whose RMS value is 20 V .
 - 14.142 V
 - 40 V
 - 10 V
 - 28.284 V
 - 20 V
- What will be the reading of an ac ammeter connected to an ac signal that varies with time according the equation $v = 7\text{ A sin}(100t)$.
 - 4.95 A
 - 14 A
 - 7 A
 - 9.899 A
 - 3.5 A

ANSWERS TO PRACTICE QUIZZES

Practice Quiz 1.1

1. A 2. D 3. D 4. D 5. A 6. B 7. E 8. D 9. C 10. B

Practice Quiz 1.2

1. C 2. B 3. E 4. B 5. E 6. E 7. B 8. A 9. E 10. D 11. D 12. A

Practice Quiz 2.1

1. C 2. A 3. C 4. A 5. A 6. D 7. B 8. C 9. A 10. D

Practice Quiz 2.2

1. D 2. B 3. C 4. E 5. E 6. C 7. C 8. A 9. E 10. E 11. C 12. A

Need help with your dissertation?

Get in-depth feedback & advice from experts in your topic area. Find out what you can do to improve the quality of your dissertation!

Get Help Now



Go to www.helpmyassignment.co.uk for more info



Practice Quiz 3.1

1. B 2. B 3. D 4. E 5. A 6. C 7. A 8. A 9. B 10. D 11. D 12. D

Practice Quiz 3.2

1. B 2. E 3. D 4. E 5. D 6. D 7. D 8. D 9. D 10. B

Practice Quiz 4.1

1. C 2. D 3. A 4. B 5. E 6. D 7. E 8. C 9. E 10. B 11. A

Practice Quiz 4.2

1. E 2. B 3. D 4. E 5. C 6. E 7. E 8. B 9. D 10. C

Practice Quiz 5.1

1. B 2. A 3. C 3. D 4. D 5. D 6. D 7. D 8. B 9. E 10. B 11. C

Practice Quiz 5.2

1. E 2. D 3. B 4. B 5. E 6. A 7. D 8. A 9. D 10. D

Practice Quiz 6.1

1. E 2. E 3. A 4. B 5. B 6. D 7. D 8. A 9. D 10. A 11. E 12. C 13. B 14. E

Practice Quiz 6.2

1. C 2. C 3. E 4. A 5. E 6. C 7. C 8. D 9. C 10. E

Practice Quiz 7.1

1. E 2. B 3. C 4. C 5. A 6. B 7. A 8. D 9. D 10. C 11. D

Practice Quiz 7.2

1. E 2. D 3. A 4. D 5. A 6. C 7. B 8. A 9. E 10. B

Practice Quiz 8.1

1. D 2. A 3. B 4. A 5. D 6. E 7. E 8. C 9. A 10. D 11. D

Practice Quiz 8.2

1. A 2. A 3. C 4. C 5. A 6. D 7. B 8. C 9. C 10. B 11. C

Practice Quiz 9.1

1. C 2. A 3. D 4. E 5. B 6. C 7. B 8. D 9. E 10. A

Practice Quiz 9.2

1. A 2. D 3. E 4. B 5. A 6. C 7. B 8. B 9. E 10. A

Practice Quiz 10.1

1 C 2. A 3. C 4. E 5. B 6. C 7. C 8. C 9. A 10. B

Practice Quiz 10.2

1. A 2. E 3. C 4. D 5. D 6. E 7. A 8. C 9. B 10. B 11. C

Practice Quiz 11.1

1. D 2. B 3. B 4. B 5. B 6. C 7. A 8. A 9. A 10. E

Practice Quiz 11.2

1. D 2. B 3. D 4. A 5. E 6. A 7. B 8. E 9. A 10. B 11. E 12. E

To see Part II download:
Sound and Electromagnetic Waves and Optics
University Physics II-Part 2: Notes and exercises